

Rack and pinion drives



STÖBER

Rack and pinion drives

One partner. All the possibilities.

STOBER has developed and produced excellent drive technology since 1934 and is active internationally with around 1000 employees at 11 locations. STOBER impresses machine manufacturers in wide-ranging industries and markets around the world with tailor-made, highly efficient drive systems for demanding movements.



"Together with our customers, we achieve perfect motion in a wide variety of applications with our precisely coordinated system. Whenever precision, dynamics and quality are required, we are at your side as a reliable partner."

Rainer Wegener, Chief Executive Officer, STÖBER Antriebstechnik

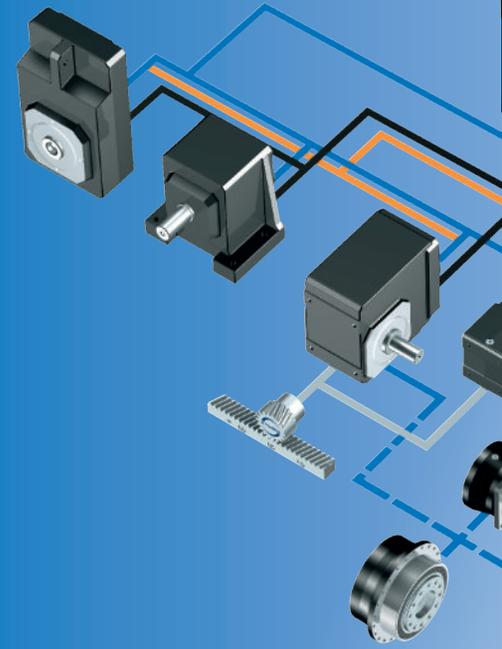

Rack and pinion drives – what you can expect!

From high flexibility to high force, the innovative system concept for rack and pinion drives from STOBER means compact, easy-to-use systems that are ready to install and adapted to various demands regarding load capacity and precision. Learn more about our special highlights: the very flexible and efficient ZV series as well as the ZTRS series with supporting bearing holder – for maximum feed force! It could not be more diverse.

At home in the world of demanding motion

Gear units

Geared motors

Motors

Cables and drive controllers

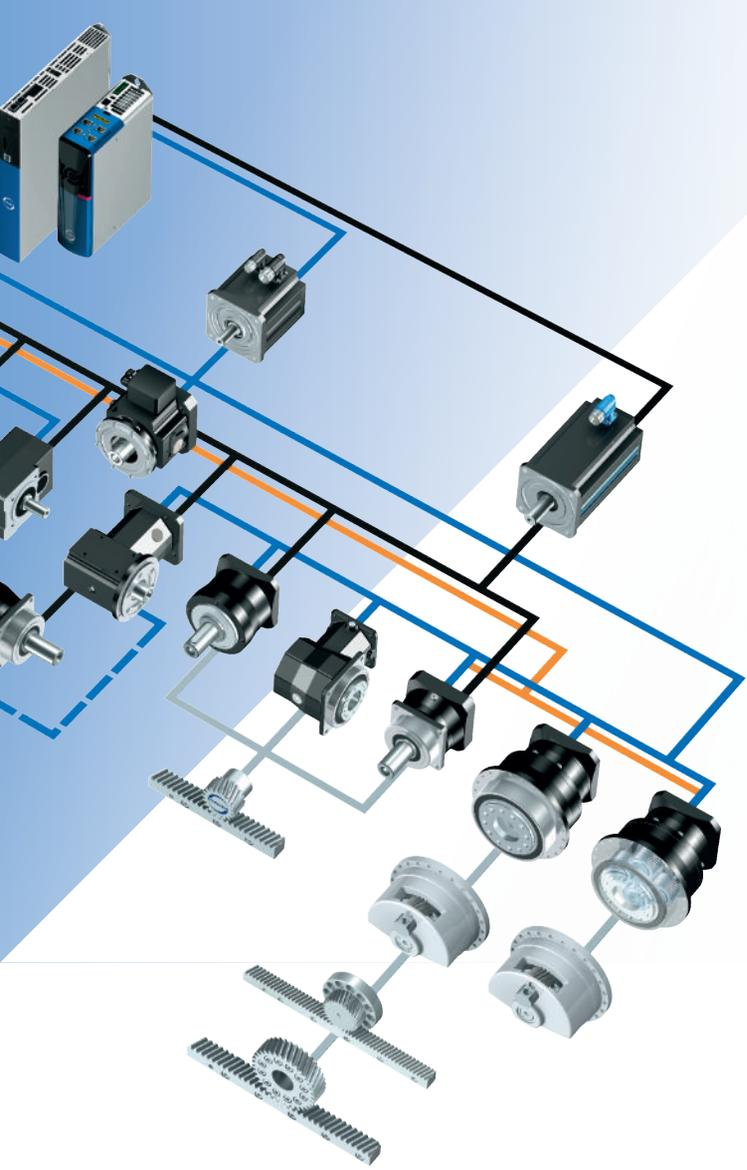

Everything from a single source.

The STÖBER drive system consisting of gear units, motors, cables and drive controllers has a modular design and is freely scalable—for tailor-made, compact and powerful machine concepts. It can be adapted to your individual requirements and combined as needed in nearly all industries and applications areas.

We check every single component and how it works together with others, taking on the responsibility for the complete drive train. For you, this means that one contact partner, certified operating safety and maximum availability are guaranteed.

Need special solutions?

Numerous one-of-a-kind product highlights and project-related adjustments make it possible. With a holistic approach to your specific task, we work together on individualized solutions that are optimally coordinated to your requirements. Dedicated and solution-oriented in the support of your visions and projects.

STÖBER moves integrally and precisely.



"Versatile products, countless possibilities. Your perfect motion is what drives us!"

Markus Graf, Chief Sales Officer, STÖBER Antriebstechnik



STOBER moves as a team and with personality.

As a family-owned company, it is very important to us to maintain close relationships and treat each other with trust. We put people first.

We are committed to the well-being of our employees, identify with the expectations of our customers, and show personal commitment to mutual success.



"We have installed gear units, motors and drive controllers from STOBER in nearly all our systems. STOBER supports us in new projects from the first stroke of a pencil in the design phase until commissioning. Our years of cooperation are shaped by openness and honesty and emanate a rather special spirit. The technical consulting, the support—that is real, experienced partnership"

Jürgen Leicht, Managing Partner of Leicht Stanzautomation

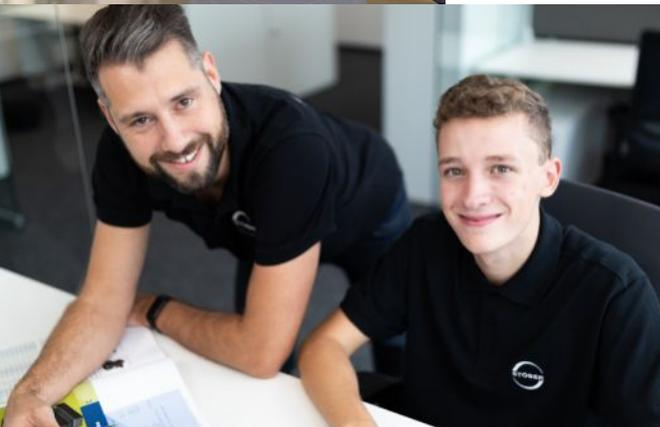

Working together. Worldwide. Successfully.

With an eye to the future, STOBER is facing the challenges of digitalization and investing in integrated solutions and a strong global presence in production, sales and service. STOBER China was founded at the end of 2019. As a result, we are present in more than 40 countries around in the world at 12 locations and with 80 service partners.



**STOBER drives
Systems technology
Taicang, China.**



Table of contents

■	1	Selection tool.....	9
■	2	ZTRSPH rack and pinion drives	13
■	3	ZTRSPHQ rack and pinion drives	31
■	4	ZTRSPHV rack and pinion drives.....	45
■	5	ZTRPH rack and pinion drives.....	57
■	6	ZTRPHV rack and pinion drives	77
■	7	ZRPH rack and pinion drives	89
■	8	ZVP rack and pinion drives.....	105
■	9	ZVPE rack and pinion drives	123
■	10	ZVKS rack and pinion drives	137
■	11	ZVKL rack and pinion drives.....	155
■	12	ZVK rack and pinion drives.....	167
■	13	ZS gear racks.....	193
■	14	Appendix	203

1 Selection tool

1.1 Rack and pinion drives



Product chapter	ZTRSPH	ZTRSPHQ	ZTRSPHV	ZTRPH	ZTRPHV	ZRPH
Chapter number	[> 2]	[> 3]	[> 4]	[> 5]	[> 6]	[> 7]

Technical data

m_n	3 – 8 mm	8 mm	5 – 8 mm	2 – 6 mm	5 – 6 mm	2 – 4 mm
z	15 – 32	19	15 – 20	12 – 32	16 – 19	30 – 40
F_{f2acc}	20 – 79 kN	124 kN	67 – 77 kN	6.5 – 67 kN	56 – 67 kN	3.1 – 16 kN
$v_{f2maxZB}$	0.2 – 4.7 m/s	0.06 – 1.1 m/s	0.21 – 0.49 m/s	0.11 – 4.7 m/s	0.2 – 0.39 m/s	0.29 – 6.7 m/s
Δs	8 – 56 μ m	70 μ m	15 – 56 μ m	4 – 44 μ m	15 – 44 μ m	10 – 56 μ m

An explanation of the formula symbols can be found in the chapter [\[> 14.1 \]](#).

Features

Power density	★★★★★	★★★★★	★★★★★	★★★★☆	★★★★☆	★★★☆☆
Linear backlash	★★★★★	★★★★☆	★★★★☆	★★★★★	★★★★☆	★★★★★
Price category	€€€€€	€€€€€	€€€€€	€€€€	€€€€	€€€
Smooth operation	★★★★☆	★★★★☆	★★★★☆	★★★★☆	★★★★☆	★★★★☆
Linear rigidity	★★★★★	★★★★★	★★★★★	★★★★☆	★★★★☆	★★★☆☆
Mass moment of inertia	★★★★☆	★★★★☆	★★★★☆	★★★★☆	★★★★☆	★★★★☆
Key	★☆☆☆☆ good ★★★★★ excellent € Economy €€€€€ Premium					

Pinion gearing						
Helical gearing	✓	✓	✓	✓	✓	✓
Gearing quality	5	5	5	5	5	5
Bearing design						
Standard	✓	✓	✓	✓	✓	✓
Reinforced				✓ (PH3 – PH5)		✓ (PH3 – PH5)
Accessories						
Felt gear	✓	✓	✓			

In the chapter [\[> 13 \]](#), you can find the matching precision gear racks for our rack and pinion drives.

1 Selection tool

1.1 Rack and pinion drives



Product chapter

ZVP

ZVPE

Chapter number

[8]

[9]

Technical data

m_n	2 – 4 mm	2 – 3 mm
z	16 – 25	16 – 25
F_{f2acc}	1.7 – 15 kN	1.7 – 6.1 kN
$v_{f2maxZB}$	0.14 – 5.3 m/s	0.14 – 4.5 m/s
Δs	8 – 44 μ m	40 – 83 μ m

An explanation of the formula symbols can be found in the chapter [▶ 14.1](#).

Features

Power density	★★★★☆	★★★★☆
Linear backlash	★★★★★	★★★★☆
Price category	€€	€
Smooth operation	★★★★☆	★★★★☆
Linear rigidity	★★★★☆	★★★★☆
Mass moment of inertia	★★★★☆	★★★★☆
Key	★★★★☆ good ★★★★★ excellent € Economy €€€€€ Premium	
Pinion gearing		
Helical gearing	✓	✓
Gearing quality	6	6
Bearing design		
Standard	✓	✓
Axially reinforced	✓	

In the chapter [▶ 13](#), you can find the matching precision gear racks for our rack and pinion drives.

1 Selection tool

1.1 Rack and pinion drives



Product chapter

ZVKS

ZVKL

ZVK

Chapter number

[\[> 10\]](#)

[\[> 11\]](#)

[\[> 12\]](#)

Technical data

m_n	2 – 4 mm	2 mm	2 – 4 mm
z	18 – 25	16 – 20	18 – 25
F_{f2acc}	3.2 – 11 kN	1.3 – 2.7 kN	2.7 – 15 kN
$v_{f2maxZB}$	0.07 – 3 m/s	0.33 – 3.3 m/s	0.06 – 3.8 m/s
Δs	37 – 44 μm	99 – 123 μm	12 – 111 μm

An explanation of the formula symbols can be found in the chapter [\[> 14.1\]](#).

Features

Power density	★★★☆☆	★★☆☆☆	★☆☆☆☆
Linear backlash	★★★☆☆	★☆☆☆☆	★★★★☆
Price category	€€€	€	€
Smooth operation	★★★★☆	★★☆☆☆	★★★★☆
Linear rigidity	★★★☆☆	★☆☆☆☆	★☆☆☆☆
Mass moment of inertia	★★★★☆	★★★★☆	★★★★☆
Key	★★☆☆☆☆ good ★★★★★ excellent € Economy €€€€€ Premium		
Pinion gearing			
Helical gearing	✓	✓	✓
Gearing quality	6	6	6

In the chapter [\[> 13\]](#), you can find the matching precision gear racks for our rack and pinion drives.

1 Selection tool

1.1 Rack and pinion drives



Product chapter

ZS gear racks

Chapter number

[▶ 13](#)

Technical data

m_n	2 – 6 mm
$F_{f,max}$	12.6 – 83.1 kN
F_{sv}	8 – 192.5 kN

An explanation of the formula symbols can be found in the chapter [▶ 14.1](#)].

Features

Helical gearing	✓
Heat-treatable steel in accordance with STOBER specification	✓
Hardened and smoothed	✓
Gearing quality 6 in accordance with DIN 3962-1	✓
Length 500 and 1000 mm	✓

2 ZTRSPH rack and pinion drives

Table of contents

2.1	Overview	14
2.2	Selection tables	15
2.3	Dimensional drawings	20
2.4	Type designation	22
2.4.1	Nameplate	23
2.5	Product description	23
2.5.1	Input options	23
2.5.2	Motor adapter with EasyAdapt coupling (ME/MEL)	24
2.5.3	Motor adapter with FlexiAdapt coupling (MF)	24
2.5.4	Gear rack	25
2.5.5	Installation conditions	25
2.5.6	Lubricants	25
2.5.7	Position of locking screw access	25
2.5.8	Other product features	25
2.5.9	Direction of rotation	26
2.6	Project configuration	26
2.6.1	Drive selection	27
2.6.2	Permitted breakdown torques at the gear unit input	29
2.6.3	Recommendation for radial shaft seal rings	30
2.7	Additional documentation	30



2 Rack and pinion drives

ZTRSPH

2.1 Overview

High-performance precision planetary gear units with supporting bearing holder

Features

Power density	★★★★★
Linear clearance	★★★★★
Price category	€€€€€
Smooth operation	★★★★☆
Linear rigidity	★★★★★
Mass moment of inertia	★★★★☆
Ready-to-install drive solution	✓
Pinion gearing quality 5 (DIN 3962)	✓
Helical gearing	✓
Case-hardened and smoothed	✓
Radial runout ≤ 10 μm (optional)	✓

Key ★☆☆☆☆ good | ★★★★★ excellent
 € Economy | €€€€€ Premium

Technical data

m_n	3 – 8 mm
z	15 – 32
F_{f2acc}	20 – 79 kN
$V_{f2maxZB}$	0.2 – 4.7 m/s
Δs	8 – 56 μm

2.2 Selection tables

The technical data specified in the selection tables applies to:

- De-energized installation
- Permanent lubrication with the lubricants recommended in the chapter on gear racks [▶ 13.5.1](#)
- Case-hardened pinions, helical (left-hand 19° 31' 42"), gearing quality 5
- Installation altitudes up to 1000 m above sea level
- Surrounding temperatures from 0 °C to 40 °C
- Without consideration of the thermal limiting performance

For rack and pinion drives with reduced backlash, higher feed forces are possible. For this and all other technical data, refer to <https://configurator.stoeber.de/en-US/>.

An explanation of the formula symbols can be found in the chapter [▶ 14.1](#).

i	Type	$n_{1\max\text{DB}}$ [rpm]	$n_{1\max\text{ZB}}$ [rpm]	d_{MW} [mm]	$v_{2\max\text{ZB}}$ [m/s]	Δs [μm]	Δs_{red} [μm]	C_{lin} [N/μm]	m_n [mm]	z	d_0 [mm]	F_{r2N} [kN]	F_{r2acc} [kN]	F_{r2NOT} [kN]	$M_{2\text{acc}}$ [Nm]
ZTRS3PH7 ($F_{\text{r2acc,max}} = 20 \text{ kN}$)															
4.000	ZTRS317SPH731_0040 ME	1900	4000	≤38	2.83	24	8	184	3	17	54.1	11	20	41	553
4.000	ZTRS317SPH731_0040 MEL	1900	4000	≤48	2.83	24	8	186	3	17	54.1	11	20	41	553
5.000	ZTRS317SPH731_0050 ME	2200	5000	≤38	2.83	24	8	181	3	17	54.1	12	20	41	553
5.000	ZTRS317SPH731_0050 MEL	2200	5000	≤48	2.83	24	8	182	3	17	54.1	12	20	41	553
7.000	ZTRS317SPH731_0070 ME	2500	5000	≤38	2.02	24	8	174	3	17	54.1	14	20	41	553
7.000	ZTRS317SPH731_0070 MEL	2500	5000	≤48	2.02	24	8	175	3	17	54.1	14	20	41	553
10.00	ZTRS317SPH731_0100 ME	2500	5000	≤38	1.42	24	8	163	3	17	54.1	13	20	41	553
10.00	ZTRS317SPH731_0100 MEL	2500	5000	≤48	1.42	24	8	163	3	17	54.1	13	20	41	553
16.00	ZTRS317SPH732_0160 ME	3000	6000	≤32	1.06	24	8	183	3	17	54.1	17	20	41	553
16.00	ZTRS317SPH732_0160 MEL	3000	6000	≤38	1.06	24	8	183	3	17	54.1	17	20	41	553
20.00	ZTRS317SPH732_0200 ME	3000	6000	≤32	0.85	24	8	180	3	17	54.1	17	20	41	553
20.00	ZTRS317SPH732_0200 MEL	3000	6000	≤38	0.85	24	8	180	3	17	54.1	17	20	41	553
25.00	ZTRS317SPH732_0250 ME	3500	7000	≤32	0.79	24	8	180	3	17	54.1	18	20	41	553
25.00	ZTRS317SPH732_0250 MEL	3500	7000	≤38	0.79	24	8	180	3	17	54.1	18	20	41	553
28.00	ZTRS317SPH732_0280 ME	3700	7000	≤32	0.71	24	8	182	3	17	54.1	20	20	41	553
28.00	ZTRS317SPH732_0280 MEL	3700	7000	≤38	0.71	24	8	182	3	17	54.1	20	20	41	553
35.00	ZTRS317SPH732_0350 ME	3700	7000	≤32	0.57	24	8	179	3	17	54.1	20	20	41	553
35.00	ZTRS317SPH732_0350 MEL	3700	7000	≤38	0.57	24	8	179	3	17	54.1	20	20	41	553
40.00	ZTRS317SPH732_0400 ME	3700	7000	≤32	0.50	24	8	179	3	17	54.1	20	20	41	553
40.00	ZTRS317SPH732_0400 MEL	3700	7000	≤38	0.50	24	8	179	3	17	54.1	20	20	41	553
50.00	ZTRS317SPH732_0500 ME	3700	7000	≤32	0.40	24	8	178	3	17	54.1	20	20	41	553
50.00	ZTRS317SPH732_0500 MEL	3700	7000	≤38	0.40	24	8	178	3	17	54.1	20	20	41	553
70.00	ZTRS317SPH732_0700 ME	3700	7000	≤32	0.28	24	8	173	3	17	54.1	20	20	41	553
70.00	ZTRS317SPH732_0700 MEL	3700	7000	≤38	0.28	24	8	173	3	17	54.1	20	20	41	553
100.0	ZTRS317SPH732_1000 ME	3700	7000	≤32	0.20	24	8	162	3	17	54.1	16	20	41	550
100.0	ZTRS317SPH732_1000 MEL	3700	7000	≤38	0.20	24	8	162	3	17	54.1	16	20	41	550
ZTRS3PH8 ($F_{\text{r2acc,max}} = 28 \text{ kN}$)															
4.000	ZTRS332SPH831_0040 ME	1400	3500	≤48	4.67	44	15	229	3	32	101.9	17	28	47	1412
4.000	ZTRS332SPH831_0040 MEL	1400	3500	≤60	4.67	44	15	235	3	32	101.9	17	28	55	1412
5.000	ZTRS332SPH831_0050 ME	1600	4000	≤48	4.27	44	15	232	3	32	101.9	22	28	55	1412
5.000	ZTRS332SPH831_0050 MEL	1600	4000	≤60	4.27	44	15	236	3	32	101.9	22	28	55	1412
7.000	ZTRS332SPH831_0070 ME	2000	4000	≤48	3.05	44	15	217	3	32	101.9	20	28	55	1412
7.000	ZTRS332SPH831_0070 MEL	2000	4000	≤60	3.05	44	15	219	3	32	101.9	20	28	55	1412
10.00	ZTRS332SPH831_0100 ME	2200	4000	≤48	2.13	44	15	195	3	32	101.9	17	27	55	1392
10.00	ZTRS332SPH831_0100 MEL	2200	4000	≤60	2.13	44	15	196	3	32	101.9	17	27	55	1392
16.00	ZTRS332SPH832_0160 ME	2500	4500	≤38	1.50	44	15	225	3	32	101.9	22	28	55	1412
16.00	ZTRS332SPH832_0160 MEL	2500	4500	≤48	1.50	44	15	226	3	32	101.9	22	28	55	1412
20.00	ZTRS332SPH832_0200 ME	2500	4500	≤38	1.20	44	15	230	3	32	101.9	25	28	55	1412
20.00	ZTRS332SPH832_0200 MEL	2500	4500	≤48	1.20	44	15	230	3	32	101.9	25	28	55	1412
25.00	ZTRS332SPH832_0250 ME	2700	5500	≤38	1.17	44	15	229	3	32	101.9	26	28	55	1412
25.00	ZTRS332SPH832_0250 MEL	2700	5500	≤48	1.17	44	15	230	3	32	101.9	26	28	55	1412
28.00	ZTRS332SPH832_0280 ME	3000	6000	≤38	1.14	44	15	223	3	32	101.9	22	28	55	1412
28.00	ZTRS332SPH832_0280 MEL	3000	6000	≤48	1.14	44	15	223	3	32	101.9	22	28	55	1412
35.00	ZTRS332SPH832_0350 ME	3000	6000	≤38	0.91	44	15	228	3	32	101.9	28	28	55	1412
35.00	ZTRS332SPH832_0350 MEL	3000	6000	≤48	0.91	44	15	228	3	32	101.9	28	28	55	1412
40.00	ZTRS332SPH832_0400 ME	3000	6000	≤38	0.80	44	15	219	3	32	101.9	22	28	55	1412
40.00	ZTRS332SPH832_0400 MEL	3000	6000	≤48	0.80	44	15	219	3	32	101.9	22	28	55	1412
50.00	ZTRS332SPH832_0500 ME	3000	6000	≤38	0.64	44	15	225	3	32	101.9	28	28	55	1412
50.00	ZTRS332SPH832_0500 MEL	3000	6000	≤48	0.64	44	15	225	3	32	101.9	28	28	55	1412

2.2 Selection tables 2 ZTRSPH rack and pinion drives

i	Type	n_{1maxDB} [rpm]	n_{1maxZB} [rpm]	d_{MW} [mm]	v_{ZmaxZB} [m/s]	Δs [μm]	Δs_{red} [μm]	C_{lin} [N/μm]	m_n [mm]	z	d_0 [mm]	F_{TZN} [kN]	F_{T2acc} [kN]	F_{T2NOT} [kN]	M_{2acc} [Nm]
ZTRS3PH8 ($F_{T2acc,max} = 28$ kN)															
70.00	ZTRS332SPH832_0700 ME	3000	6000	≤38	0.46	44	15	214	3	32	101.9	28	28	55	1412
70.00	ZTRS332SPH832_0700 MEL	3000	6000	≤48	0.46	44	15	214	3	32	101.9	28	28	55	1412
100.0	ZTRS332SPH832_1000 ME	3000	6000	≤38	0.32	44	15	194	3	32	101.9	21	27	54	1380
100.0	ZTRS332SPH832_1000 MEL	3000	6000	≤48	0.32	44	15	194	3	32	101.9	21	27	54	1380
ZTRS4PH8 ($F_{T2acc,max} = 45$ kN)															
4.000	ZTRS420SPH831_0040 ME	1400	3500	≤48	3.89	37	12	282	4	20	84.9	21	43	57	1820
4.000	ZTRS420SPH831_0040 MEL	1400	3500	≤60	3.89	37	12	288	4	20	84.9	21	43	70	1820
5.000	ZTRS420SPH831_0050 ME	1600	4000	≤48	3.56	37	12	285	4	20	84.9	26	45	70	1929
5.000	ZTRS420SPH831_0050 MEL	1600	4000	≤60	3.56	37	12	289	4	20	84.9	26	45	70	1929
7.000	ZTRS420SPH831_0070 ME	2000	4000	≤48	2.54	37	12	269	4	20	84.9	24	45	70	1929
7.000	ZTRS420SPH831_0070 MEL	2000	4000	≤60	2.54	37	12	271	4	20	84.9	24	45	70	1929
10.00	ZTRS420SPH831_0100 ME	2200	4000	≤48	1.78	37	12	245	4	20	84.9	20	33	66	1392
10.00	ZTRS420SPH831_0100 MEL	2200	4000	≤60	1.78	37	12	246	4	20	84.9	20	33	66	1392
16.00	ZTRS420SPH832_0160 ME	2500	4500	≤38	1.25	37	12	278	4	20	84.9	26	45	70	1929
16.00	ZTRS420SPH832_0160 MEL	2500	4500	≤48	1.25	37	12	279	4	20	84.9	26	45	70	1929
20.00	ZTRS420SPH832_0200 ME	2500	4500	≤38	1.00	37	12	283	4	20	84.9	29	45	70	1929
20.00	ZTRS420SPH832_0200 MEL	2500	4500	≤48	1.00	37	12	283	4	20	84.9	29	45	70	1929
25.00	ZTRS420SPH832_0250 ME	2700	5500	≤38	0.98	37	12	282	4	20	84.9	31	45	70	1929
25.00	ZTRS420SPH832_0250 MEL	2700	5500	≤48	0.98	37	12	283	4	20	84.9	31	45	70	1929
28.00	ZTRS420SPH832_0280 ME	3000	6000	≤38	0.95	37	12	276	4	20	84.9	26	45	70	1929
28.00	ZTRS420SPH832_0280 MEL	3000	6000	≤48	0.95	37	12	276	4	20	84.9	26	45	70	1929
35.00	ZTRS420SPH832_0350 ME	3000	6000	≤38	0.76	37	12	281	4	20	84.9	34	45	70	1929
35.00	ZTRS420SPH832_0350 MEL	3000	6000	≤48	0.76	37	12	281	4	20	84.9	34	45	70	1929
40.00	ZTRS420SPH832_0400 ME	3000	6000	≤38	0.67	37	12	271	4	20	84.9	26	45	70	1920
40.00	ZTRS420SPH832_0400 MEL	3000	6000	≤48	0.67	37	12	271	4	20	84.9	26	45	70	1920
50.00	ZTRS420SPH832_0500 ME	3000	6000	≤38	0.53	37	12	278	4	20	84.9	37	45	70	1929
50.00	ZTRS420SPH832_0500 MEL	3000	6000	≤48	0.53	37	12	278	4	20	84.9	37	45	70	1929
70.00	ZTRS420SPH832_0700 ME	3000	6000	≤38	0.38	37	12	266	4	20	84.9	33	44	70	1848
70.00	ZTRS420SPH832_0700 MEL	3000	6000	≤48	0.38	37	12	266	4	20	84.9	33	44	70	1848
100.0	ZTRS420SPH832_1000 ME	3000	6000	≤38	0.27	37	12	244	4	20	84.9	25	33	65	1380
100.0	ZTRS420SPH832_1000 MEL	3000	6000	≤48	0.27	37	12	244	4	20	84.9	25	33	65	1380
ZTRS5PH8 ($F_{T2acc,max} = 49$ kN)															
4.000	ZTRS516SPH831_0040 ME	1400	3500	≤48	3.89	37	12	292	5	16	84.9	21	43	57	1820
4.000	ZTRS516SPH831_0040 MEL	1400	3500	≤60	3.89	37	12	299	5	16	84.9	21	43	70	1820
5.000	ZTRS516SPH831_0050 ME	1600	4000	≤48	3.56	37	12	296	5	16	84.9	26	49	70	2100
5.000	ZTRS516SPH831_0050 MEL	1600	4000	≤60	3.56	37	12	300	5	16	84.9	26	49	70	2100
7.000	ZTRS516SPH831_0070 ME	2000	4000	≤48	2.54	37	12	279	5	16	84.9	24	47	70	2000
7.000	ZTRS516SPH831_0070 MEL	2000	4000	≤60	2.54	37	12	281	5	16	84.9	24	47	70	2000
10.00	ZTRS516SPH831_0100 ME	2200	4000	≤48	1.78	37	12	253	5	16	84.9	20	33	66	1392
10.00	ZTRS516SPH831_0100 MEL	2200	4000	≤60	1.78	37	12	254	5	16	84.9	20	33	66	1392
16.00	ZTRS516SPH832_0160 ME	2500	4500	≤38	1.25	37	12	289	5	16	84.9	26	47	70	2000
16.00	ZTRS516SPH832_0160 MEL	2500	4500	≤48	1.25	37	12	289	5	16	84.9	26	47	70	2000
20.00	ZTRS516SPH832_0200 ME	2500	4500	≤38	1.00	37	12	293	5	16	84.9	29	49	70	2100
20.00	ZTRS516SPH832_0200 MEL	2500	4500	≤48	1.00	37	12	294	5	16	84.9	29	49	70	2100
25.00	ZTRS516SPH832_0250 ME	2700	5500	≤38	0.98	37	12	293	5	16	84.9	31	49	70	2100
25.00	ZTRS516SPH832_0250 MEL	2700	5500	≤48	0.98	37	12	293	5	16	84.9	31	49	70	2100
28.00	ZTRS516SPH832_0280 ME	3000	6000	≤38	0.95	37	12	286	5	16	84.9	26	47	70	2000
28.00	ZTRS516SPH832_0280 MEL	3000	6000	≤48	0.95	37	12	286	5	16	84.9	26	47	70	2000
35.00	ZTRS516SPH832_0350 ME	3000	6000	≤38	0.76	37	12	292	5	16	84.9	34	49	70	2100
35.00	ZTRS516SPH832_0350 MEL	3000	6000	≤48	0.76	37	12	292	5	16	84.9	34	49	70	2100
40.00	ZTRS516SPH832_0400 ME	3000	6000	≤38	0.67	37	12	281	5	16	84.9	26	45	70	1920
40.00	ZTRS516SPH832_0400 MEL	3000	6000	≤48	0.67	37	12	281	5	16	84.9	26	45	70	1920
50.00	ZTRS516SPH832_0500 ME	3000	6000	≤38	0.53	37	12	289	5	16	84.9	37	49	70	2100
50.00	ZTRS516SPH832_0500 MEL	3000	6000	≤48	0.53	37	12	289	5	16	84.9	37	49	70	2100
70.00	ZTRS516SPH832_0700 ME	3000	6000	≤38	0.38	37	12	275	5	16	84.9	33	44	70	1848
70.00	ZTRS516SPH832_0700 MEL	3000	6000	≤48	0.38	37	12	275	5	16	84.9	33	44	70	1848
100.0	ZTRS516SPH832_1000 ME	3000	6000	≤38	0.27	37	12	252	5	16	84.9	25	33	65	1380
100.0	ZTRS516SPH832_1000 MEL	3000	6000	≤48	0.27	37	12	252	5	16	84.9	25	33	65	1380
ZTRS5PH9 ($F_{T2acc,max} = 77$ kN)															
12.00	ZTRS520SPH942_0120 ME	1800	3000	≤48	1.39	46	15	396	5	20	106.1	56	77	132	4075
12.00	ZTRS520SPH942_0120 MEL	1800	3000	≤60	1.39	46	15	398	5	20	106.1	56	77	154	4075
16.00	ZTRS520SPH942_0160 ME	2000	3500	≤48	1.22	46	15	395	5	20	106.1	57	77	154	4075
16.00	ZTRS520SPH942_0160 MEL	2000	3500	≤60	1.22	46	15	396	5	20	106.1	57	77	154	4075
18.00	ZTRS520SPH942_0180 ME	1800	3000	≤48	0.93	46	15	389	5	20	106.1	57	77	154	4075
18.00	ZTRS520SPH942_0180 MEL	1800	3000	≤60	0.93	46	15	390	5	20	106.1	57	77	154	4075
20.00	ZTRS520SPH942_0200 ME	2500	4000	≤48	1.11	46	15	394	5	20	106.1	57	77	154	4075

i	Type	n_{1maxDB} [rpm]	n_{1maxZB} [rpm]	d_{MW} [mm]	v_{ZmaxZB} [m/s]	Δs [μm]	Δs_{red} [μm]	C_{lin} [N/μm]	m_n [mm]	z	d_0 [mm]	F_{t2N} [kN]	F_{t2acc} [kN]	F_{t2NOT} [kN]	M_{2acc} [Nm]
ZTRS5PH9 ($F_{t2acc,max} = 77$ kN)															
20.00	ZTRS520SPH942_0200 MEL	2500	4000	≤60	1.11	46	15	395	5	20	106.1	57	77	154	4075
24.00	ZTRS520SPH942_0240 ME	2000	3500	≤48	0.81	46	15	388	5	20	106.1	57	77	154	4075
24.00	ZTRS520SPH942_0240 MEL	2000	3500	≤60	0.81	46	15	388	5	20	106.1	57	77	154	4075
28.00	ZTRS520SPH942_0280 ME	2800	4500	≤48	0.89	46	15	391	5	20	106.1	66	77	154	4075
28.00	ZTRS520SPH942_0280 MEL	2800	4500	≤60	0.89	46	15	392	5	20	106.1	66	77	154	4075
30.00	ZTRS520SPH942_0300 ME	2500	4000	≤48	0.74	46	15	388	5	20	106.1	62	77	154	4075
30.00	ZTRS520SPH942_0300 MEL	2500	4000	≤60	0.74	46	15	388	5	20	106.1	62	77	154	4075
32.00	ZTRS520SPH942_0320 ME	2800	4500	≤48	0.78	46	15	387	5	20	106.1	60	77	154	4075
32.00	ZTRS520SPH942_0320 MEL	2800	4500	≤60	0.78	46	15	388	5	20	106.1	60	77	154	4075
40.00	ZTRS520SPH942_0400 ME	2800	4500	≤48	0.63	46	15	383	5	20	106.1	60	77	154	4075
40.00	ZTRS520SPH942_0400 MEL	2800	4500	≤60	0.63	46	15	383	5	20	106.1	60	77	154	4075
42.00	ZTRS520SPH942_0420 ME	2800	4500	≤48	0.60	46	15	387	5	20	106.1	66	77	154	4075
42.00	ZTRS520SPH942_0420 MEL	2800	4500	≤60	0.60	46	15	387	5	20	106.1	66	77	154	4075
48.00	ZTRS520SPH942_0480 ME	2800	4500	≤48	0.52	46	15	385	5	20	106.1	66	77	154	4075
48.00	ZTRS520SPH942_0480 MEL	2800	4500	≤60	0.52	46	15	385	5	20	106.1	66	77	154	4075
60.00	ZTRS520SPH942_0600 ME	2800	4500	≤48	0.42	46	15	383	5	20	106.1	66	77	154	4075
60.00	ZTRS520SPH942_0600 MEL	2800	4500	≤60	0.42	46	15	383	5	20	106.1	66	77	154	4075
ZTRS6PH9 ($F_{t2acc,max} = 77$ kN)															
12.00	ZTRS620SPH942_0120 ME	1800	3000	≤48	1.67	56	19	370	6	20	127.3	47	72	110	4600
12.00	ZTRS620SPH942_0120 MEL	1800	3000	≤60	1.67	56	19	373	6	20	127.3	47	72	145	4600
16.00	ZTRS620SPH942_0160 ME	2000	3500	≤48	1.46	56	19	368	6	20	127.3	47	77	147	4919
16.00	ZTRS620SPH942_0160 MEL	2000	3500	≤60	1.46	56	19	370	6	20	127.3	47	77	150	4919
18.00	ZTRS620SPH942_0180 ME	1800	3000	≤48	1.11	56	19	361	6	20	127.3	47	77	150	4919
18.00	ZTRS620SPH942_0180 MEL	1800	3000	≤60	1.11	56	19	362	6	20	127.3	47	77	150	4919
20.00	ZTRS620SPH942_0200 ME	2500	4000	≤48	1.33	56	19	368	6	20	127.3	47	77	150	4919
20.00	ZTRS620SPH942_0200 MEL	2500	4000	≤60	1.33	56	19	368	6	20	127.3	47	77	150	4919
24.00	ZTRS620SPH942_0240 ME	2000	3500	≤48	0.97	56	19	360	6	20	127.3	47	77	150	4919
24.00	ZTRS620SPH942_0240 MEL	2000	3500	≤60	0.97	56	19	361	6	20	127.3	47	77	150	4919
28.00	ZTRS620SPH942_0280 ME	2800	4500	≤48	1.07	56	19	364	6	20	127.3	55	77	150	4919
28.00	ZTRS620SPH942_0280 MEL	2800	4500	≤60	1.07	56	19	365	6	20	127.3	55	77	150	4919
30.00	ZTRS620SPH942_0300 ME	2500	4000	≤48	0.89	56	19	360	6	20	127.3	52	77	150	4919
30.00	ZTRS620SPH942_0300 MEL	2500	4000	≤60	0.89	56	19	360	6	20	127.3	52	77	150	4919
32.00	ZTRS620SPH942_0320 ME	2800	4500	≤48	0.94	56	19	359	6	20	127.3	50	72	145	4600
32.00	ZTRS620SPH942_0320 MEL	2800	4500	≤60	0.94	56	19	360	6	20	127.3	50	72	145	4600
40.00	ZTRS620SPH942_0400 ME	2800	4500	≤48	0.75	56	19	354	6	20	127.3	50	72	145	4600
40.00	ZTRS620SPH942_0400 MEL	2800	4500	≤60	0.75	56	19	354	6	20	127.3	50	72	145	4600
42.00	ZTRS620SPH942_0420 ME	2800	4500	≤48	0.71	56	19	359	6	20	127.3	55	77	150	4919
42.00	ZTRS620SPH942_0420 MEL	2800	4500	≤60	0.71	56	19	359	6	20	127.3	55	77	150	4919
48.00	ZTRS620SPH942_0480 ME	2800	4500	≤48	0.63	56	19	356	6	20	127.3	55	77	150	4919
48.00	ZTRS620SPH942_0480 MEL	2800	4500	≤60	0.63	56	19	356	6	20	127.3	55	77	150	4919
60.00	ZTRS620SPH942_0600 ME	2800	4500	≤48	0.50	56	19	354	6	20	127.3	55	77	150	4919
60.00	ZTRS620SPH942_0600 MEL	2800	4500	≤60	0.50	56	19	354	6	20	127.3	55	77	150	4919
ZTRS8PH9 ($F_{t2acc,max} = 79$ kN)															
12.00	ZTRS815SPH942_0120 ME	1800	3000	≤48	1.67	56	19	389	8	15	127.3	47	72	110	4600
12.00	ZTRS815SPH942_0120 MEL	1800	3000	≤60	1.67	56	19	391	8	15	127.3	47	72	145	4600
16.00	ZTRS815SPH942_0160 ME	2000	3500	≤48	1.46	56	19	386	8	15	127.3	47	79	147	5000
16.00	ZTRS815SPH942_0160 MEL	2000	3500	≤60	1.46	56	19	388	8	15	127.3	47	79	150	5000
18.00	ZTRS815SPH942_0180 ME	1800	3000	≤48	1.11	56	19	378	8	15	127.3	47	79	150	5000
18.00	ZTRS815SPH942_0180 MEL	1800	3000	≤60	1.11	56	19	379	8	15	127.3	47	79	150	5000
20.00	ZTRS815SPH942_0200 ME	2500	4000	≤48	1.33	56	19	385	8	15	127.3	47	79	150	5000
20.00	ZTRS815SPH942_0200 MEL	2500	4000	≤60	1.33	56	19	386	8	15	127.3	47	79	150	5000
24.00	ZTRS815SPH942_0240 ME	2000	3500	≤48	0.97	56	19	377	8	15	127.3	47	79	150	5000
24.00	ZTRS815SPH942_0240 MEL	2000	3500	≤60	0.97	56	19	378	8	15	127.3	47	79	150	5000
28.00	ZTRS815SPH942_0280 ME	2800	4500	≤48	1.07	56	19	382	8	15	127.3	55	79	150	5000
28.00	ZTRS815SPH942_0280 MEL	2800	4500	≤60	1.07	56	19	382	8	15	127.3	55	79	150	5000
30.00	ZTRS815SPH942_0300 ME	2500	4000	≤48	0.89	56	19	377	8	15	127.3	52	79	150	5000
30.00	ZTRS815SPH942_0300 MEL	2500	4000	≤60	0.89	56	19	377	8	15	127.3	52	79	150	5000
32.00	ZTRS815SPH942_0320 ME	2800	4500	≤48	0.94	56	19	376	8	15	127.3	50	72	145	4600
32.00	ZTRS815SPH942_0320 MEL	2800	4500	≤60	0.94	56	19	377	8	15	127.3	50	72	145	4600
40.00	ZTRS815SPH942_0400 ME	2800	4500	≤48	0.75	56	19	371	8	15	127.3	50	72	145	4600
40.00	ZTRS815SPH942_0400 MEL	2800	4500	≤60	0.75	56	19	371	8	15	127.3	50	72	145	4600
42.00	ZTRS815SPH942_0420 ME	2800	4500	≤48	0.71	56	19	375	8	15	127.3	55	79	150	5000
42.00	ZTRS815SPH942_0420 MEL	2800	4500	≤60	0.71	56	19	376	8	15	127.3	55	79	150	5000
48.00	ZTRS815SPH942_0480 ME	2800	4500	≤48	0.63	56	19	373	8	15	127.3	55	79	150	5000
48.00	ZTRS815SPH942_0480 MEL	2800	4500	≤60	0.63	56	19	373	8	15	127.3	55	79	150	5000

2.2 Selection tables 2 ZTRSPH rack and pinion drives

i	Type	n_{1maxDB} [rpm]	n_{1maxZB} [rpm]	d_{MW} [mm]	$v_{f2maxZB}$ [m/s]	Δs [μ m]	Δs_{red} [μ m]	C_{lin} [N/ μ m]	m_n [mm]	z	d_0 [mm]	F_{f2N} [kN]	F_{f2acc} [kN]	F_{f2NOT} [kN]	M_{2acc} [Nm]
ZTRS8PH9 ($F_{f2acc,max} = 79$ kN)															
60.00	ZTRS815SPH942_0600 ME	2800	4500	≤ 48	0.50	56	19	371	8	15	127.3	55	79	150	5000
60.00	ZTRS815SPH942_0600 MEL	2800	4500	≤ 60	0.50	56	19	371	8	15	127.3	55	79	150	5000

2.3 Dimensional drawings

In this chapter, you can find the dimensions of the rack and pinion drives with motor adapter.

Dimension az in the tables of dimensions applies to STÖBER gear racks. In general: $az = \frac{1}{2} d_0 + h_0 + x \cdot m_n$

The pinion of the rack and pinion drive is helical (left-hand $19^\circ 31' 42''$). The pinion gearing quality is 5.

Dimensions can exceed the specifications of ISO 2768-mK due to casting tolerances or accumulation of individual tolerances.

We reserve the right to make dimensional changes due to ongoing technical development.

You can download 3D models of our standard drives at <https://configurator.stoeber.de/en-US/>.

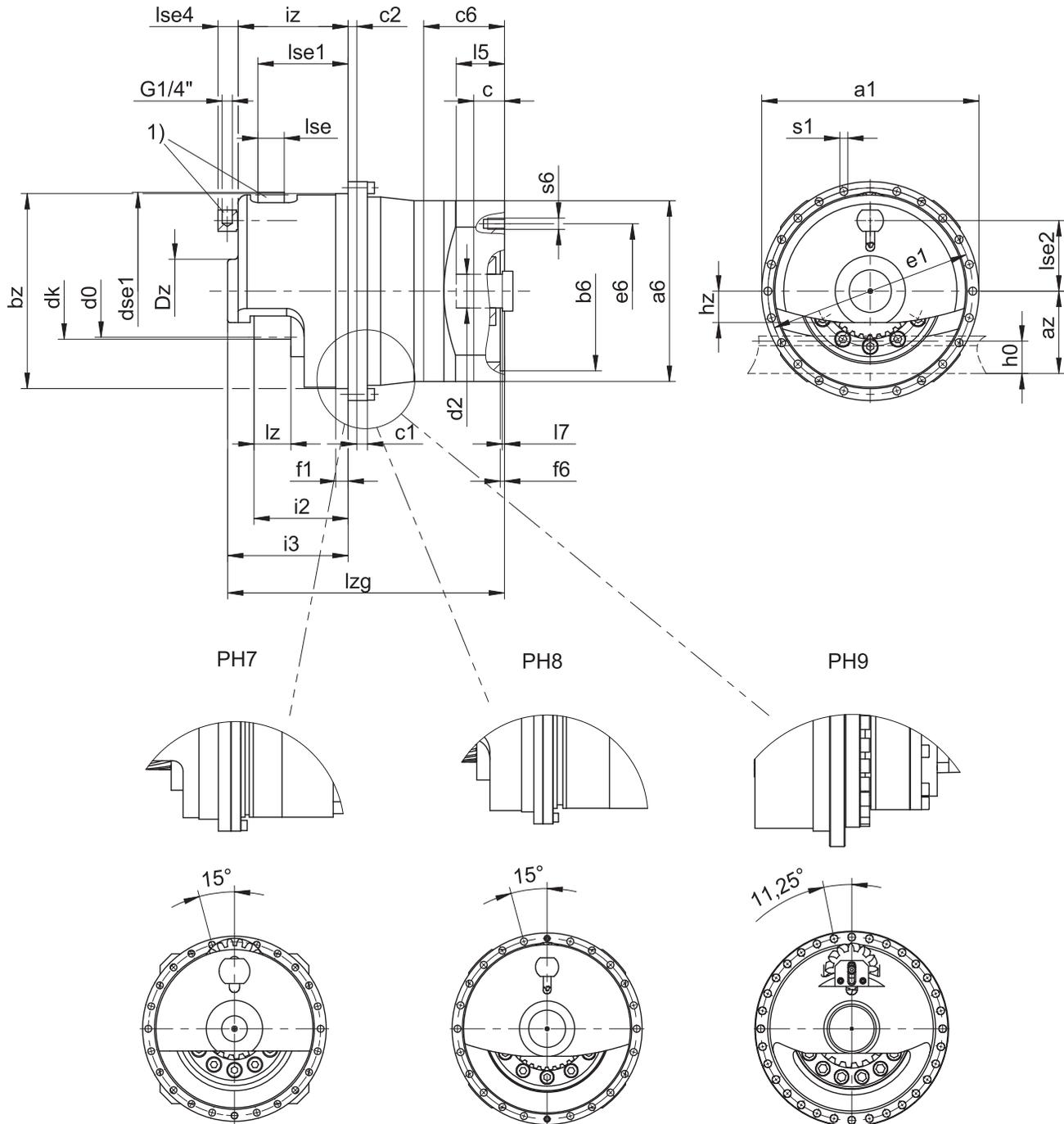

1) Felt gear for lubrication (option)

Output dimensions

Type	mn	Øa1	az	Øbz	c1	c2	d0	dk	dse1	Dz	Øe1	f1	i2	i3	iz	h0	hz	lz	lse	lse1	lse2	lse4	Øs1	x
ZTRS317SPH7_	3	179	53.06	156 _{h7}	10	12	54.11	60.1	63.6	55	168	19.0	78.5	99.5	89.5	26	21.5	32.5	25	75.2	55.7	23.0	6.6	0.0
ZTRS332SPH8_	3	247	76.93	220 _{h7}	12	10	101.86	107.9	63.6	72	233	14.0	107.0	137.0	125.0	26	35.5	42.0	30	102.6	79.5	23.0	9.0	0.0
ZTRS420SPH8_	4	247	77.44	220 _{h7}	12	10	84.88	92.8	62.8	72	233	14.0	110.0	137.0	125.0	35	35.5	45.0	30	98.6	68.9	23.0	9.0	0.0
ZTRS516SPH8_	5	247	76.44	220 _{h7}	12	10	84.88	94.8	78.6	72	233	14.5	120.0	147.0	135.0	34	35.5	55.0	30	109.6	76.5	23.0	9.0	0.0
ZTRS520SPH9_	5	346	87.05	300 _{h7}	18	18	106.10	116.1	78.6	100	325	21.5	137.0	179.0	171.0	34	45.0	55.0	30	131.1	87.1	–	13.5	0.0
ZTRS620SPH9_	6	346	106.66	300 _{h7}	18	18	127.32	139.3	94.2	100	325	21.5	147.0	189.0	181.0	43	43.5	65.0	30	131.1	104.8	–	13.5	0.0
ZTRS815SPH9_	8	346	136.66	300 _{h7}	18	18	127.32	147.3	160.0	110	325	21.5	162.0	204.7	196.5	71	55.0	80.0	65	162.0	137.7	5.5	13.5	0.3

Example dimensions for the motor connection + total length

Type	Øb6	Øe6	Ød2max	l5	□a6	c	c6	f6	l7	lzg	s6
ZTRS3_PH731_ME	130 ^{H7}	165	38	61	150	26	66.0	5.5	4.5	234.5	M10
ZTRS3_PH732_ME	110 ^{H7}	130	32	51	120	24	54.0	4.0	4.5	272.5	M8
ZTRS3_PH831_ME	180 ^{H7}	215	48	83	204	35	80.5	5.5	8.5	315.0	M12
ZTRS4_PH831_ME	180 ^{H7}	215	48	83	204	35	80.5	5.5	8.5	315.0	M12
ZTRS5_PH831_ME	180 ^{H7}	215	48	83	204	35	80.5	5.5	8.5	325.0	M12
ZTRS3_PH832_ME	130 ^{H7}	165	38	61	150	26	66.0	5.5	4.5	360.0	M10
ZTRS4_PH832_ME	130 ^{H7}	165	38	61	150	26	66.0	5.5	4.5	360.0	M10
ZTRS5_PH832_ME	130 ^{H7}	165	38	61	150	26	66.0	5.5	4.5	370.0	M10
ZTRS5_PH942_ME	180 ^{H7}	215	48	83	204	35	80.5	5.5	8.5	465.5	M12
ZTRS6_PH942_ME	180 ^{H7}	215	48	83	204	35	80.5	5.5	8.5	475.5	M12
ZTRS8_PH942_ME	180 ^{H7}	215	48	83	204	35	80.5	5.5	8.5	491.2	M12

In the table above, you will find example dimensions for the motor connection for the ME motor adapter.

Note that when dimension c is lengthened, dimensions c6, l5 and lzg are also lengthened accordingly.

You will find additional motor connection dimensions for motor adapters ME, MEL and MF in our STOEGER Configurator at <https://configurator.stoeber.de/en-US/>. Here, you can directly download a 3D model of your drive.

2.4 Type designation

This chapter shows you an explanation of the type designation with the associated options.

Additional ordering information not included in the type designation can be found at the end of the chapter.

Example code

Z	TRS	3	17	S	PH	7	3	1	S	F	S	S	0050	ME
---	-----	---	----	---	----	---	---	---	---	---	---	---	------	----

Explanation

Code	Designation	Design
Z	Type	Rack and pinion drive
TRS	Design	Screwed flange pinion with supporting bearing holder
3	Normal module	$m_n = 3$ mm (example)
17	Number of teeth	$z = 17$ (example)
S	Toothing	Helical (left-hand 19° 31' 42")
SF	Toothing	Helical (left-hand 19° 31' 42") with felt gear for lubrication
PH	Type	Planetary gear unit
7	Size	7 (example)
3	Generation	Generation 3
4	Generation	Generation 4
1	Stages	Single-stage
2	Stages	Two-stage
S	Housing	Standard
F	Shaft	Flange shaft
S	Bearing	Standard bearing
V	Bearing	Reinforced bearing (PH3 – PH5)
S	Backlash	Standard
R	Backlash	Reduced
0050	Transmission ratio ($i \times 10$)	$i = 5$ (example)
ME	Motor adapter	Motor adapter with EasyAdapt coupling
MEL	Motor adapter	Motor adapter with EasyAdapt coupling for large motors
MF	Motor adapter	Motor adapter with FlexiAdapt coupling
MB ¹	Motor adapter	ServoStop motor adapter with brake

To complete the type designation, also specify the following in your order:

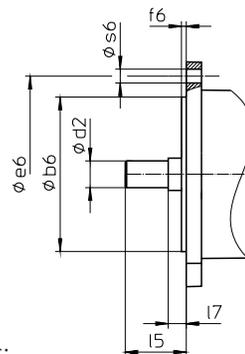

- Motor type or motor dimensions:

To choose a suitable motor connection, use the STOBER Configurator at

<https://configurator.stoeber.de/en-US/> and choose your motor or the dimensions of the motor connection.

- Position of the gear rack, see the chapter [▶ 2.5.7]
- Radial shaft seal rings at the output made of NBR or FKM (option), see the chapter [▶ 2.6.3]
- Radial runout $\leq 10 \mu\text{m}$ (optional)
- Reverse operation of the output shaft from $\pm 20^\circ$ to $\pm 90^\circ$ for horizontal installation on request

- Double seal for motor adapter (option)
- Socket wrench insert for mounting the motor on the gear unit using the ME/MEL/MF motor adapter (option)

In this product catalog, you will find all the information about rack and pinion drives with a motor adapter. All input options available upon request are listed in the chapter [\[▶ 2.5.1\]](#).

2.4.1 Nameplate

An example gear unit nameplate is explained in the figure below.

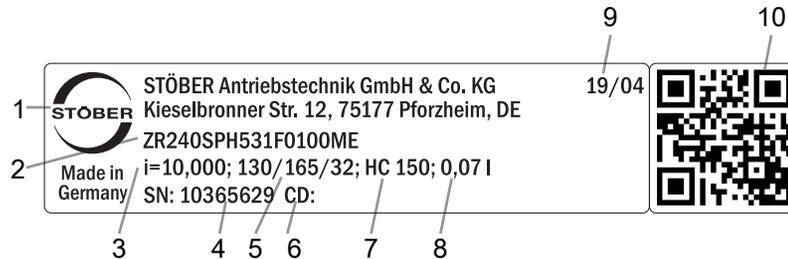

Code	Designation
1	Name of manufacturer
2	Type designation
3	Gear ratio of the gear unit
4	Serial number of the gear unit
5	Dimensions of the motor adapter (pilot/bolt circle/motor shaft diameter)
6	Customer-specific data
7	Lubricant specification
8	Lubricant fill volume
9	Date of manufacture (year/calendar week)
10	QR code (link to product information)

2.4.1.1 Supporting documents

You can view or download supporting documents for the product by reading off the serial number on the nameplate of the product and entering it at the following address online:

<https://id.stober.com>

Alternatively, you can use a suitable mobile device to scan in the QR code on the nameplate of the product in order to be linked to the supporting documents.

2.5 Product description

2.5.1 Input options

In this chapter, you will find all available input options:

Motor adapter



Catalog ID 443137_en

EZ synchronous servo motor



Catalog ID 443286_en

KX right-angle input with MF motor adapter



On request

K right-angle input with ME motor adapter



On request

MB motor adapter



On request

The corresponding catalogs can be found at <http://www.stober.de/en/downloads/>

Enter the ID of the catalog in the [Search term](#) field.

2.5.2 Motor adapter with EasyAdapt coupling (ME/MEL)

In this chapter, you will find a description of the EasyAdapt coupling.

Properties:

- Fast and easy motor attachment
- One-piece, rugged clamp coupling with expanding function
- Lowest mass moments of inertia for the highest dynamics
- Balanced for smooth running without vibration, even at high speeds
- Large selection of motor shaft diameters and lengths
- Error-free, thanks to exact centering of the motor
- For reduced backlash, the motor shaft bearing must have an axially backlash-free design



Fig. 1: EasyAdapt coupling

2.5.3 Motor adapter with FlexiAdapt coupling (MF)

In this chapter, you will find a description of the FlexiAdapt coupling.

Properties:

- Fast and easy motor attachment
- Rugged, laser-welded bellow coupling with expanding function
- With integrated thermal length compensation, compensates for linear expansion of the motor shaft
- Motor shaft decoupled from axial forces
- Balanced for smooth running without vibration, even at high speeds
- Large selection of motor shaft diameters and lengths
- Error-free, thanks to exact centering of the motor



Fig. 2: FlexiAdapt coupling

2.5.4 Gear rack

The gear rack used must have a right-hand design (19° 31' 42"); the load capacity must not be exceeded.

When using a STOBBER gear rack, please also observe the project configuration in the chapter [\[13.6\]](#).

2.5.5 Installation conditions

The torque and force values listed in this catalog are valid under the following conditions:

- When the gear housing is fastened on the machine side using screws of strength class 12.9
- When the gear housings are adjusted at pilot \varnothing bz. The machine-side fit must be H7.

2.5.6 Lubricants

STOBBER fills the gear units with the amount and type of lubricant specified on the nameplate.

You will receive lubricants for use in the food industry upon request.

2.5.6.1 Rack and pinion drive lubrication

Ensure permanent lubrication with the lubricants recommended in the chapter [\[13.5.1\]](#).

2.5.7 Position of locking screw access

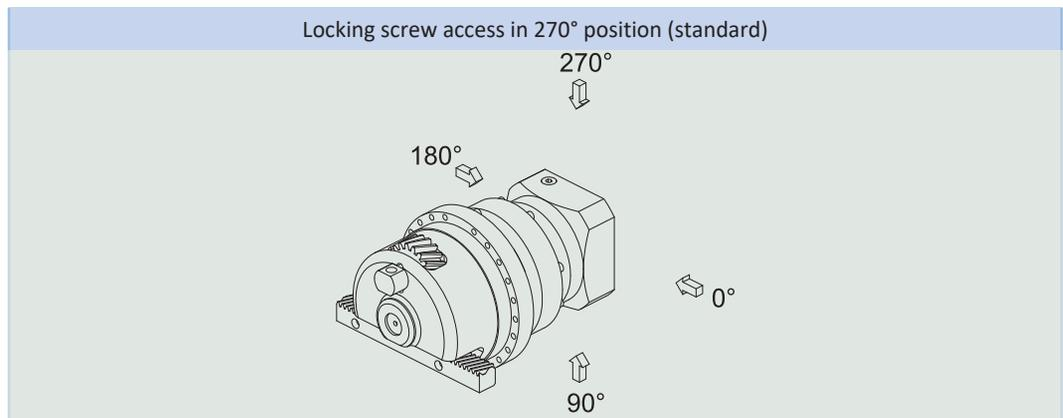

The access hole for the motor coupling locking screw in the standard version is in the 270° position. Indicate variations for your rack and pinion drive in the order.

Note that the access hole for the motor coupling locking screw also rotates when the gear rack is rotated to another position.

2.5.8 Other product features

Feature	Value
Max. permitted gear unit temperature (on the surface of the gear unit)	≤ 90 °C
Paint	Black RAL 9005
(ATEX) Directive 2014/34/EU (optional)	Not suitable.
Protection class: ²	
Planetary gear unit	IP65
Pinion/gear rack	IPXX

²Observe the protection class of all the components.

2.5.9 Direction of rotation

The input and output rotate in the same direction.

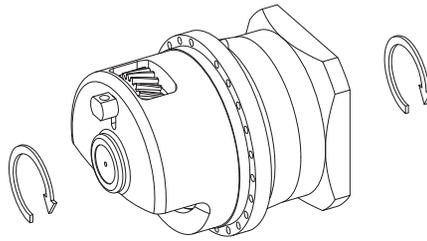

2.6 Project configuration

Project your drives using our SERVOfsoft designing software. Download SERVOfsoft free of charge after registration at <https://www.stoeber.de/en/services/info-servosoft/>.

It is the most convenient and reliable method of drive selection, as the entire torque/speed curve of the application is displayed and evaluated here in the curve of the geared motor.

In this chapter, only limit values for specific operating points can be taken into consideration for manual drive selection.

The formula symbols for values actually present in the application are marked with *.

An explanation of the formula symbols can be found in the chapter [▶ 14.1].

2.6.1 Drive selection

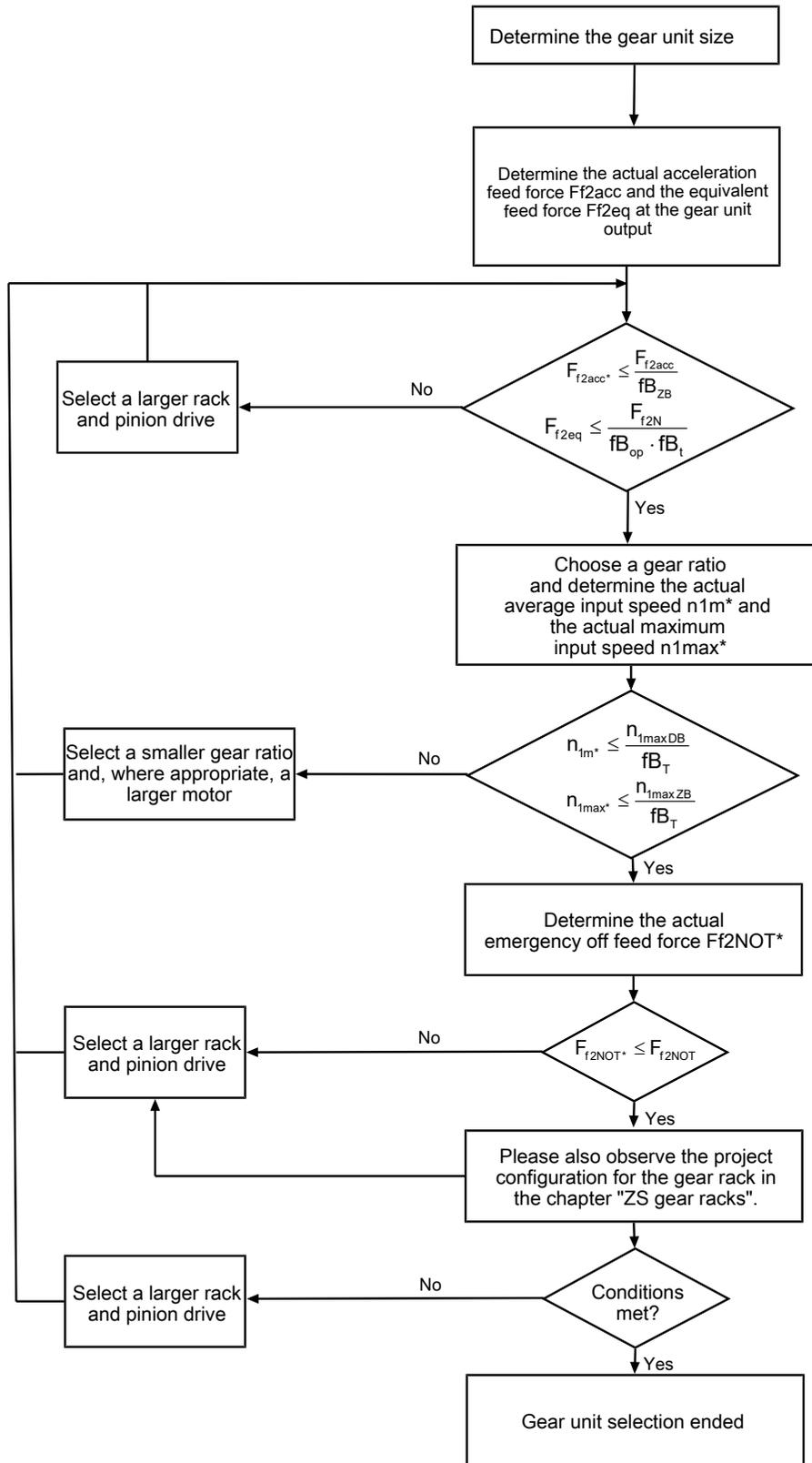

Refer to the selection tables for the values for i , n_{1maxDB} , n_{1maxZB} , F_{f2acc} , F_{f2N} and F_{f2NOT} .

The values for f_{B_T} , $f_{B_{op}}$, f_{B_t} and $f_{B_{zB}}$ can be found in the corresponding tables in this chapter.

Example of cyclic operation

The following calculations are based on a representation of the power taken from the output based in accordance with the following example:

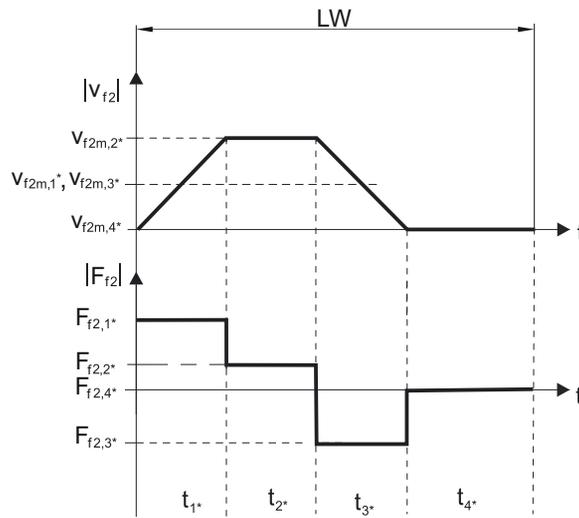

Calculation of the actual maximum acceleration feed force

$$F_{f2acc*} = m \cdot a^* + F_{L*}$$

Calculation of the actual average input speed

$$n_{1m*} = \frac{v_{f2m*} \cdot i}{d_0 \cdot \pi}$$

$$v_{f2m*} = \frac{|v_{f2m,1*}| \cdot t_{1*} + \dots + |v_{f2m,n*}| \cdot t_{n*}}{t_{1*} + \dots + t_{n*}}$$

If $t_{1*} + \dots + t_{3*} \geq 6$ min, determine v_{2m*} without the rest phase t_{4*} .

The values for the ratio i can be found in the selection tables.

Calculation of the actual emergency off feed force

$$F_{f2NOT*} = m \cdot a_{NOT*} + F_{L*}$$

Calculation of the actual equivalent feed force

$$F_{f2eq*} = \sqrt[3]{\frac{|v_{f2m,1*}| \cdot t_{1*} \cdot |F_{f2,1*}|^3 + \dots + |v_{f2m,n*}| \cdot t_{n*} \cdot |F_{f2,n*}|^3}{|v_{f2m,1*}| \cdot t_{1*} + \dots + |v_{f2m,n*}| \cdot t_{n*}}}$$

Operating factors

Operating mode	fB_{op}
Uniform continuous operation	1.00
Cyclic operation	1.00
Reversing load cyclic operation	1.00
Run time	fB_t
Daily runtime ≤ 8 h	1.00
Daily runtime ≤ 16 h	1.15
Daily runtime ≤ 24 h	1.20
Cyclic operation	fB_{ZB}
≤ 1000 load changes/hour (LW/h)	1.00
> 1000 load changes/hour (LW/h)	1.15

Temperature		f_{B_T}
Motor cooling	Surrounding temperature	
Motor with forced ventilation	$\leq 20\text{ °C}$	0.9
	$\leq 30\text{ °C}$	1.0
	$\leq 40\text{ °C}$	1.15
Motor with convection cooling	$\leq 20\text{ °C}$	1.0
	$\leq 30\text{ °C}$	1.1
	$\leq 40\text{ °C}$	1.25

Notes

- The maximum permitted gear unit temperature (see the "Other product features" chapter) must not be exceeded, as that could result in damage.
- For braking from full speed (for example, when the power fails or when setting up the machine), note the permitted gear unit feed forces (F_{f2acc} , F_{f2NOT}) in the selection tables.

2.6.2 Permitted breakdown torques at the gear unit input

For a horizontal mounting position of the motor, verify that the permitted breakdown torque at the gear unit input is not exceeded before installation on a STOBBER gear unit. You can find information for how to do that in this chapter.

Calculate the actual breakdown torque as follows:

$$M_{1k^*} = F_{1k^*} \cdot l_{sp} \leq M_{1k}$$

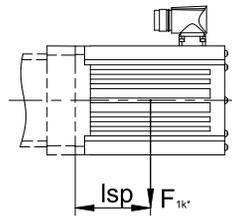

Type	M_{1k} [Nm]
PH331_ME	20
PH332_ME	10
PH431_ME	40
PH432_ME	20
PH531_ME	80
PH532_ME	40
PH731_ME	200
PH732_ME	80
PH831_ME	400
PH832_ME	200
PH942_ME	400
PH1042_ME	400

The values also apply to the MEL and MF motor adapters.

2.6.3 Recommendation for radial shaft seal rings

For a duty cycle > 60% and higher surrounding temperatures, we recommend radial shaft seal rings made of FKM at the output.

Properties:

- Excellent temperature resistance
- High chemical stability
- Very good resistance to aging
- Excellent resistance in oils and greases
- For use in the food, beverage and pharmaceutical industries

Leak-proofness

Our gear units are equipped with high-quality radial shaft seal rings and checked for leaks. However, a leak cannot be fully ruled out over the length of use of a gear unit. If you use a gear unit with goods incompatible with the lubricant, you must take measures to prevent direct contact with the gear unit lubricant in case of a leak.

2.7 Additional documentation

Additional documentation related to the product can be found at

<http://www.stoeber.de/en/downloads/>

Enter the ID of the documentation in the Search term field.

Documentation	ID
Operating manual gear units, geared motors PH33 – PH83, PH94 – PH104	443354_en
Operating manual gear racks	443392_en

3 ZTRSPHQ rack and pinion drives

Table of contents

3.1	Overview	32
3.2	Selection tables	33
3.3	Dimensional drawings	34
3.4	Type designation	35
3.4.1	Nameplate	36
3.5	Product description	36
3.5.1	Input options	36
3.5.2	Motor adapter with EasyAdapt coupling (ME/MEL)	37
3.5.3	Gear rack	37
3.5.4	Installation conditions	37
3.5.5	Lubricants	37
3.5.6	Mounting positions	38
3.5.7	Position of locking screw access	38
3.5.8	Other product features	38
3.5.9	Direction of rotation	39
3.6	Project configuration	39
3.6.1	Drive selection	40
3.6.2	Permitted breakdown torques at the gear unit input	42
3.6.3	Recommendation for radial shaft seal rings	43
3.7	Additional documentation	43



3 Rack and pinion drives

ZTRSPHQ

3.1 Overview

Quattro-Power precision planetary gear units with supporting bearing holder

Features

Power density	★★★★★
Linear clearance	★★★★☆
Price category	€€€€€
Smooth operation	★★★★☆
Linear rigidity	★★★★★
Mass moment of inertia	★★★★☆
Ready-to-install drive solution	✓
Pinion gearing quality 5 (DIN 3962)	✓
Helical gearing	✓
Case-hardened and smoothed	✓
Radial runout ≤ 10 µm (optional)	✓

Key ★☆☆☆☆ good | ★★★★★ excellent
 € Economy | €€€€€ Premium

Technical data

m_n	8 mm
z	19
F_{f2acc}	124 kN
$V_{f2maxZB}$	0.06 – 1.1 m/s
Δs	70 µm

3.2 Selection tables

The technical data specified in the selection tables applies to:

- De-energized installation
- Permanent lubrication with the lubricants recommended in the chapter on gear racks ▶ 13.5.1]
- Case-hardened pinions, helical (left-hand 19° 31' 42"), gearing quality 5
- Installation altitudes up to 1000 m above sea level
- Surrounding temperatures from 0 °C to 40 °C
- Without consideration of the thermal limiting performance

For all other technical data, refer to <https://configurator.stoeber.de/en-US/>.

An explanation of the formula symbols can be found in the chapter ▶ 14.1].

i	Type	n_{1maxDB} [rpm]	n_{1maxZB} [rpm]	d_{MW} [mm]	$v_{f2maxZB}$ [m/s]	Δs [μm]	Δs_{red} [μm]	C_{lin} [N/μm]	m_n [mm]	z	d_0 [mm]	F_{f2N} [kN]	F_{f2acc} [kN]	F_{f2NOT} [kN]	M_{2acc} [Nm]
ZTRS8PHQ10 ($F_{f2acc,max} = 124$ kN)															
24.00	ZTRS819SPHQ1042_0240 ME	1800	3000	≤60	1.06	70	–	341	8	19	161.3	65	124	240	10000
30.00	ZTRS819SPHQ1042_0300 ME	2000	3500	≤60	0.99	70	–	340	8	19	161.3	66	124	240	10000
42.00	ZTRS819SPHQ1042_0420 ME	2300	4000	≤60	0.80	70	–	339	8	19	161.3	66	124	240	10000
60.00	ZTRS819SPHQ1042_0600 ME	2500	4000	≤60	0.56	70	–	335	8	19	161.3	66	124	240	10000
96.00	ZTRS819SPHQ1043_0960 ME	2000	3500	≤48	0.31	70	–	340	8	19	161.3	66	124	240	10000
96.00	ZTRS819SPHQ1043_0960 MEL	2000	3500	≤60	0.31	70	–	340	8	19	161.3	66	124	240	10000
120.0	ZTRS819SPHQ1043_1200 ME	2000	3500	≤48	0.25	70	–	340	8	19	161.3	66	124	240	10000
120.0	ZTRS819SPHQ1043_1200 MEL	2000	3500	≤60	0.25	70	–	340	8	19	161.3	66	124	240	10000
150.0	ZTRS819SPHQ1043_1500 ME	2500	4000	≤48	0.23	70	–	340	8	19	161.3	66	124	240	10000
150.0	ZTRS819SPHQ1043_1500 MEL	2500	4000	≤60	0.23	70	–	340	8	19	161.3	66	124	240	10000
168.0	ZTRS819SPHQ1043_1680 ME	2800	4500	≤48	0.23	70	–	340	8	19	161.3	66	124	240	10000
168.0	ZTRS819SPHQ1043_1680 MEL	2800	4500	≤60	0.23	70	–	340	8	19	161.3	66	124	240	10000
210.0	ZTRS819SPHQ1043_2100 ME	2800	4500	≤48	0.18	70	–	340	8	19	161.3	66	124	240	10000
210.0	ZTRS819SPHQ1043_2100 MEL	2800	4500	≤60	0.18	70	–	340	8	19	161.3	66	124	240	10000
240.0	ZTRS819SPHQ1043_2400 ME	2800	4500	≤48	0.16	70	–	340	8	19	161.3	66	124	240	10000
240.0	ZTRS819SPHQ1043_2400 MEL	2800	4500	≤60	0.16	70	–	340	8	19	161.3	66	124	240	10000
300.0	ZTRS819SPHQ1043_3000 ME	2800	4500	≤48	0.13	70	–	340	8	19	161.3	66	124	240	10000
300.0	ZTRS819SPHQ1043_3000 MEL	2800	4500	≤60	0.13	70	–	340	8	19	161.3	66	124	240	10000
420.0	ZTRS819SPHQ1043_4200 ME	2800	4500	≤48	0.09	70	–	339	8	19	161.3	66	124	240	10000
420.0	ZTRS819SPHQ1043_4200 MEL	2800	4500	≤60	0.09	70	–	339	8	19	161.3	66	124	240	10000
600.0	ZTRS819SPHQ1043_6000 ME	2800	4500	≤48	0.06	70	–	335	8	19	161.3	66	124	240	10000
600.0	ZTRS819SPHQ1043_6000 MEL	2800	4500	≤60	0.06	70	–	335	8	19	161.3	66	124	240	10000

3.3 Dimensional drawings

In this chapter, you can find the dimensions of the rack and pinion drives with motor adapter.

Dimension az in the tables of dimensions applies to STOBBER gear racks. In general: $az = \frac{1}{2} d_0 + h_0 + x \cdot mn$

The pinion of the rack and pinion drive is helical (left-hand 19° 31' 42"). The pinion gearing quality is 5.

Dimensions can exceed the specifications of ISO 2768-mK due to casting tolerances or accumulation of individual tolerances.

We reserve the right to make dimensional changes due to ongoing technical development.

You can download 3D models of our standard drives at <https://configurator.stoeber.de/en-US/>.

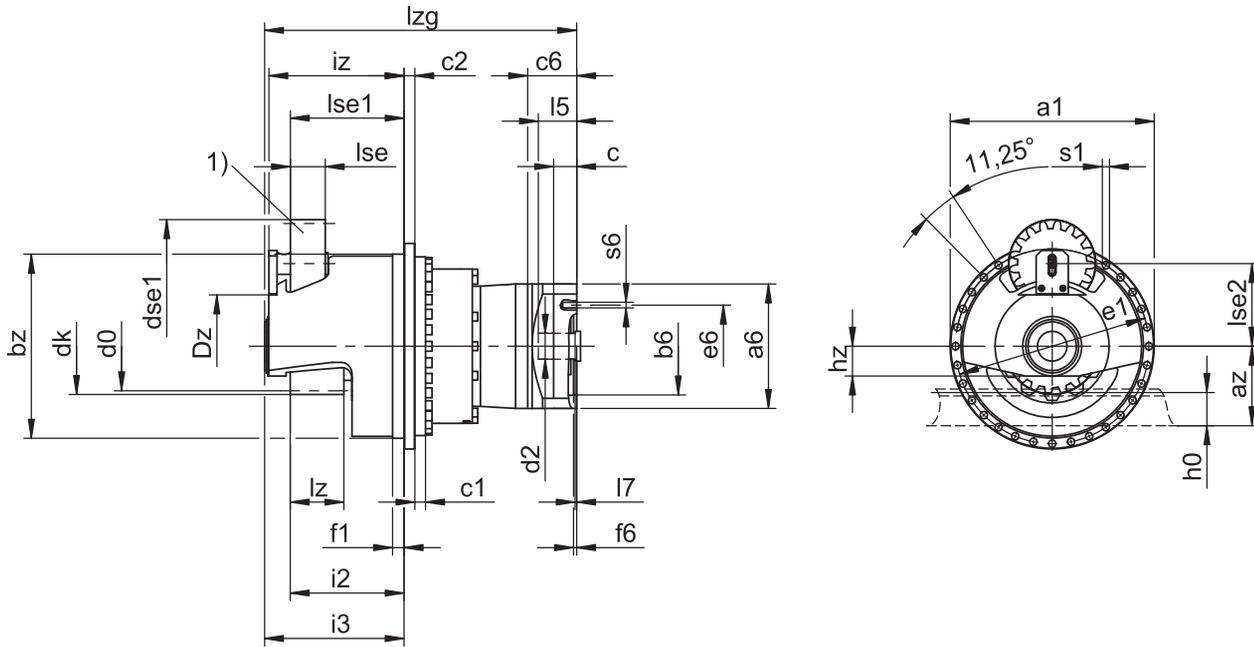

1) Felt gear for lubrication (option)

Output dimensions

Type	mn	Øa1	az	Øbz	c1	c2	d0	dk	dse1	Dz	Øe1	f1	i2	i3	iz	h0	hz	lz	lse	lse1	lse2	Øs1	x
ZTRS819SPHQ10_	8	380	151.64	340 _{h7}	20	20	161.28	177.3	160.0	110	360	21.5	212	260	251.9	71	55	100	65	211.7	152.8	13.5	0.00

Example dimensions for the motor connection + total length

Type	Øb6	Øe6	Ød2max	l5	□a6	c	c6	f6	l7	lzg	s6
ZTRS8_PHQ1042_ME	180 ^{H7}	215	60	85	230	43	91.5	6.0	10.5	581.5	M12
ZTRS8_PHQ1043_ME	180 ^{H7}	215	48	83	204	35	80.5	5.5	8.5	662.5	M12

In the table above, you will find example dimensions for the motor connection for the ME motor adapter.

Note that when dimension c is lengthened, dimensions c6, l5 and lzg are also lengthened accordingly.

You will find additional motor connection dimensions for motor adapters ME and MEL in our STOBBER Configurator at <https://configurator.stoeber.de/en-US/>. Here, you can directly download a 3D model of your drive.

3.4 Type designation

This chapter shows you an explanation of the type designation with the associated options.

Additional ordering information not included in the type designation can be found at the end of the chapter.

Example code

Z	TRS	8	19	S	PHQ	10	4	3	S	F	S	S	1680	ME
---	-----	---	----	---	-----	----	---	---	---	---	---	---	------	----

Explanation

Code	Designation	Design
Z	Type	Rack and pinion drive
TRS	Design	Screwed flange pinion with supporting bearing holder
8	Normal module	$m_n = 8$ mm (example)
19	Number of teeth	$z = 19$ (example)
S	Toothing	Helical (left-hand 19° 31' 42")
SF		Helical (left-hand 19° 31' 42") with felt gear for lubrication
PHQ	Type	Planetary gear unit
10	Size	10 (example)
4	Generation	Generation 4
2	Stages	Two-stage
3		Three-stage
S	Housing	Standard
F	Shaft	Flange shaft
S	Bearing	Standard bearing
S	Backlash	Standard
1680	Transmission ratio ($i \times 10$)	$i = 168$ (example)
ME	Motor adapter	Motor adapter with EasyAdapt coupling
MEL		Motor adapter with EasyAdapt coupling for large motors
MB ¹		ServoStop motor adapter with brake

To complete the type designation, also specify the following in your order:

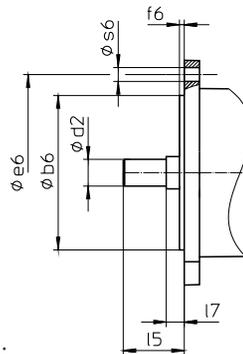

- Motor type or motor dimensions:
To choose a suitable motor connection, use the STOBER Configurator at <https://configurator.stoeber.de/en-US/> and choose your motor or the dimensions of the motor connection.
- Mounting position (for three-stage gear units), see the chapter [▶ 3.5.6]
- Position of the gear rack, see the chapter [▶ 3.5.7]
- Radial shaft seal rings at the output made of NBR or FKM (option), see the chapter [▶ 3.6.3]
- Radial runout $\leq 10 \mu\text{m}$ (optional)
- Reverse operation of the output shaft from $\pm 20^\circ$ to $\pm 90^\circ$ for horizontal installation on request
- Double seal for motor adapter (option)
- Socket wrench insert for mounting the motor on the gear unit using the ME/MEL motor adapter (optional)

In this product catalog, you will find all the information about rack and pinion drives with a motor adapter. All input options available upon request are listed in the chapter [▶ 3.5.1].

¹You can find more details in the catalog for ServoStop servo gear unit with brake ID 443234.

3.4.1 Nameplate

An example gear unit nameplate is explained in the figure below.

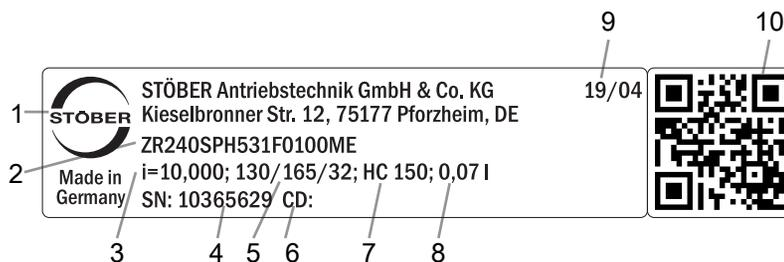

Code	Designation
1	Name of manufacturer
2	Type designation
3	Gear ratio of the gear unit
4	Serial number of the gear unit
5	Dimensions of the motor adapter (pilot/bolt circle/motor shaft diameter)
6	Customer-specific data
7	Lubricant specification
8	Lubricant fill volume
9	Date of manufacture (year/calendar week)
10	QR code (link to product information)

3.4.1.1 Supporting documents

You can view or download supporting documents for the product by reading off the serial number on the nameplate of the product and entering it at the following address online:

<https://id.stober.com>

Alternatively, you can use a suitable mobile device to scan in the QR code on the nameplate of the product in order to be linked to the supporting documents.

3.5 Product description

3.5.1 Input options

In this chapter, you will find all available input options:

Motor adapter



Catalog ID 443137_en

EZ synchronous servo motor



Catalog ID 443286_en

K right-angle input with ME motor adapter



On request

MB motor adapter



On request

The corresponding catalogs can be found at <http://www.stober.de/en/downloads/>

Enter the ID of the catalog in the Search term field.

3.5.2 Motor adapter with EasyAdapt coupling (ME/MEL)

In this chapter, you will find a description of the EasyAdapt coupling.

Properties:

- Fast and easy motor attachment
- One-piece, rugged clamp coupling with expanding function
- Lowest mass moments of inertia for the highest dynamics
- Balanced for smooth running without vibration, even at high speeds
- Large selection of motor shaft diameters and lengths
- Error-free, thanks to exact centering of the motor
- For reduced backlash, the motor shaft bearing must have an axially backlash-free design



Fig. 1: EasyAdapt coupling

3.5.3 Gear rack

The gear rack used must have a right-hand design (19° 31' 42"); the load capacity must not be exceeded.

When using a STOBBER gear rack, please also observe the project configuration in the chapter [▶ 13.6](#).

3.5.4 Installation conditions

The torque and force values listed in this catalog are valid under the following conditions:

- When the gear housing is fastened on the machine side using screws of strength class 12.9
- When the gear housings are adjusted at pilot \varnothing bz. The machine-side fit must be H7.

3.5.5 Lubricants

STOBBER fills the gear units with the amount and type of lubricant specified on the nameplate. The filling volume and the structure of the gear units depend on the mounting position.

Only install the gear units in the intended mounting position! Reposition the gear units only after consulting STOBBER. Otherwise, STOBBER assumes no liability for the gear units.

You will receive lubricants for use in the food industry upon request.

3.5.5.1 Rack and pinion drive lubrication

Ensure permanent lubrication with the lubricants recommended in the chapter [▶ 13.5.1](#).

3.5.6 Mounting positions

The following table shows the standard mounting positions.

Please indicate the mounting position when ordering 3-stage gear units.

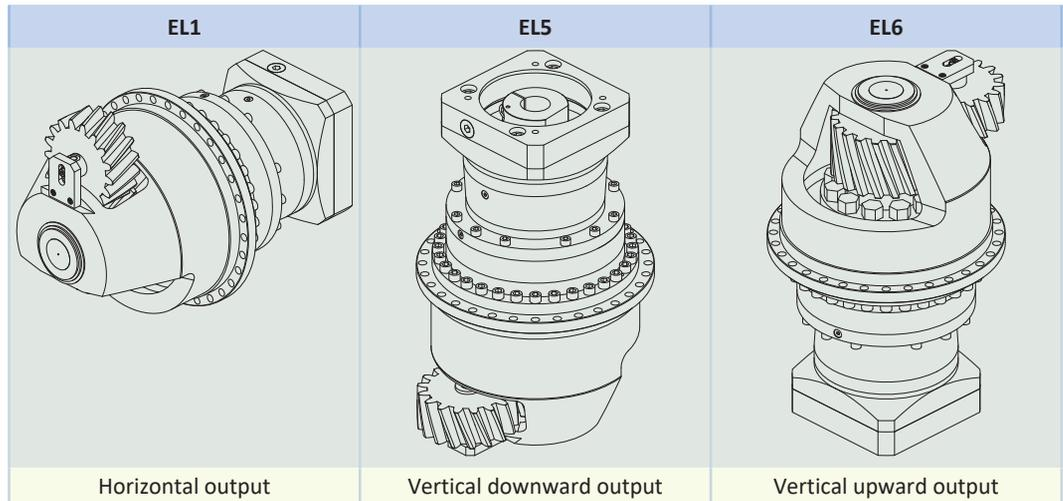

3.5.7 Position of locking screw access

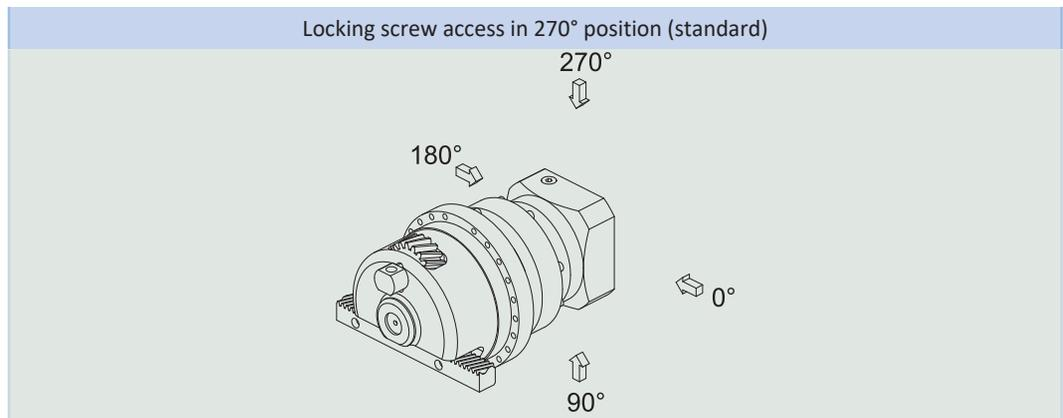

The access hole for the motor coupling locking screw in the standard version is in the 270° position. Indicate variations for your rack and pinion drive in the order.

Note that the access hole for the motor coupling locking screw also rotates when the gear rack is rotated to another position.

3.5.8 Other product features

Feature	Value
Max. permitted gear unit temperature (on the surface of the gear unit)	≤ 90 °C
Paint	Black RAL 9005
(ATEX) Directive 2014/34/EU (optional)	Not suitable.
Protection class: ²	
Planetary gear unit	IP65
Pinion/gear rack	IPXX

²Observe the protection class of all the components.

3.5.9 Direction of rotation

The input and output rotate in the same direction.

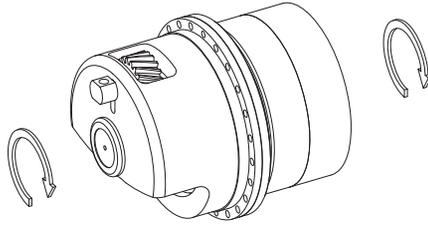

3.6 Project configuration

Project your drives using our SERVOfsoft designing software. Download SERVOfsoft free of charge after registration at <https://www.stoeber.de/en/services/info-servosoft/>.

It is the most convenient and reliable method of drive selection, as the entire torque/speed curve of the application is displayed and evaluated here in the curve of the geared motor.

In this chapter, only limit values for specific operating points can be taken into consideration for manual drive selection.

The formula symbols for values actually present in the application are marked with *.

An explanation of the formula symbols can be found in the chapter [▶ 14.1](#)].

3.6.1 Drive selection

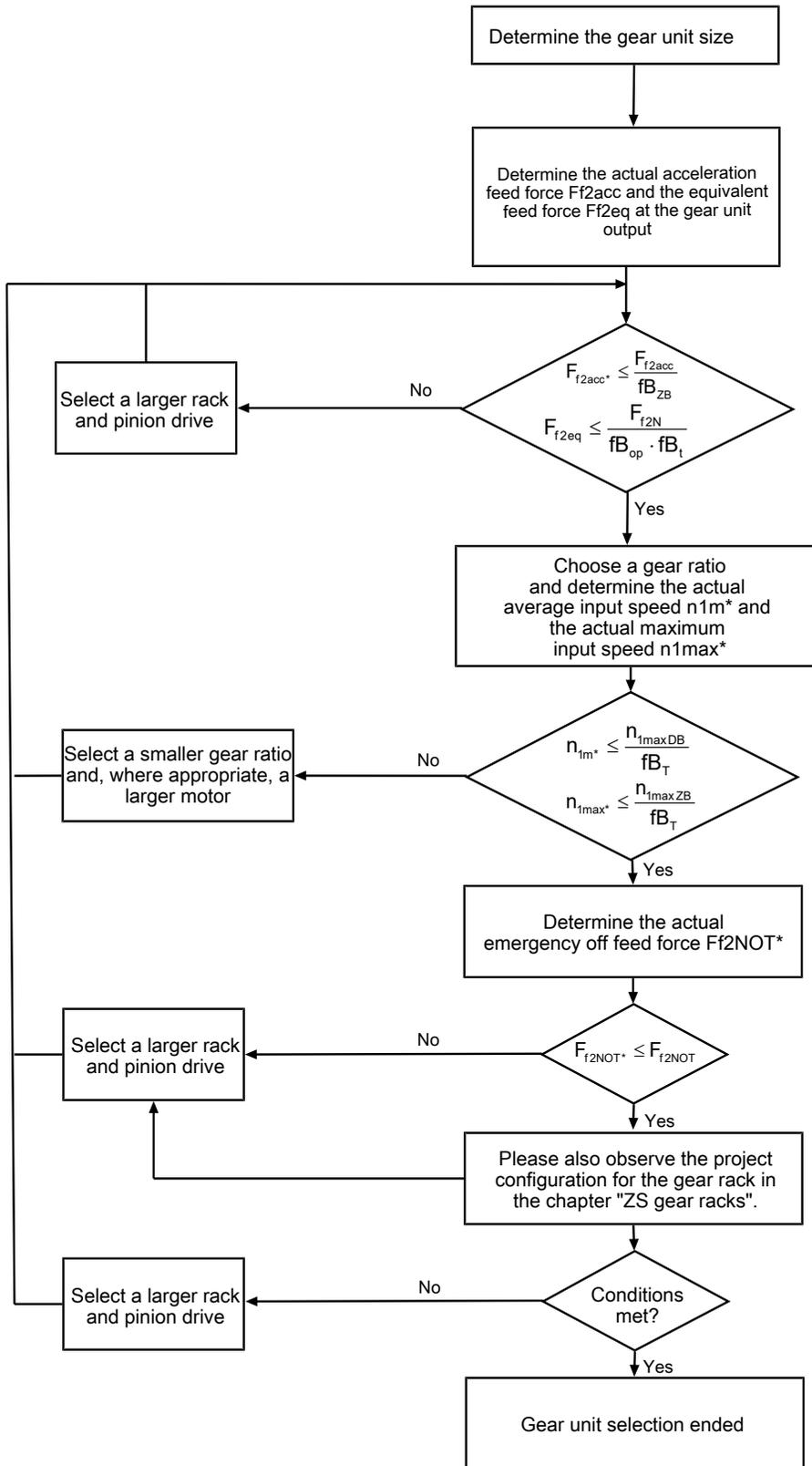

Refer to the selection tables for the values for i , n_{1maxDB} , n_{1maxZB} , F_{f2acc} , F_{f2N} and F_{f2NOT} .

The values for fB_T , fB_{op} , fB_t and fB_{zB} can be found in the corresponding tables in this chapter.

Example of cyclic operation

The following calculations are based on a representation of the power taken from the output based in accordance with the following example:

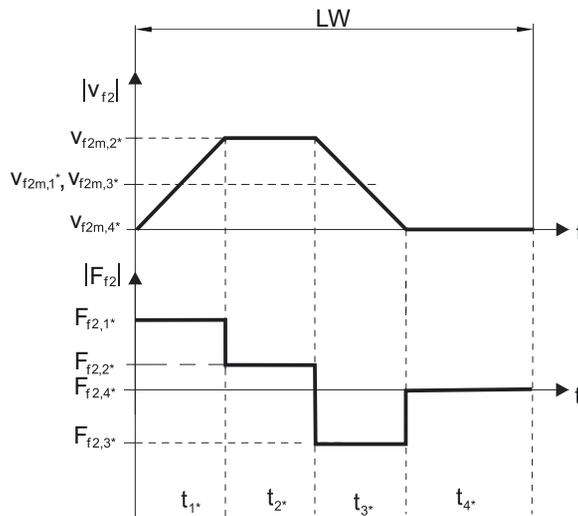

Calculation of the actual maximum acceleration feed force

$$F_{f2acc*} = m \cdot a^* + F_{L*}$$

Calculation of the actual average input speed

$$n_{1m*} = \frac{v_{f2m*} \cdot i}{d_0 \cdot \pi}$$

$$v_{f2m*} = \frac{|v_{f2m,1*}| \cdot t_{1*} + \dots + |v_{f2m,n*}| \cdot t_{n*}}{t_{1*} + \dots + t_{n*}}$$

If $t_{1*} + \dots + t_{3*} \geq 6$ min, determine v_{2m*} without the rest phase t_{4*} .

The values for the ratio i can be found in the selection tables.

Calculation of the actual emergency off feed force

$$F_{f2NOT*} = m \cdot a_{NOT*} + F_{L*}$$

Calculation of the actual equivalent feed force

$$F_{f2eq*} = \sqrt[3]{\frac{|v_{f2m,1*}| \cdot t_{1*} \cdot |F_{f2,1*}|^3 + \dots + |v_{f2m,n*}| \cdot t_{n*} \cdot |F_{f2,n*}|^3}{|v_{f2m,1*}| \cdot t_{1*} + \dots + |v_{f2m,n*}| \cdot t_{n*}}}$$

Operating factors

Operating mode	fB_{op}
Uniform continuous operation	1.00
Cyclic operation	1.00
Reversing load cyclic operation	1.00
Run time	fB_t
Daily runtime ≤ 8 h	1.00
Daily runtime ≤ 16 h	1.15
Daily runtime ≤ 24 h	1.20
Cyclic operation	fB_{ZB}
≤ 1000 load changes/hour (LW/h)	1.00
> 1000 load changes/hour (LW/h)	1.15

Temperature		f_{B_T}
Motor cooling	Surrounding temperature	
Motor with forced ventilation	$\leq 20\text{ °C}$	0.9
	$\leq 30\text{ °C}$	1.0
	$\leq 40\text{ °C}$	1.15
Motor with convection cooling	$\leq 20\text{ °C}$	1.0
	$\leq 30\text{ °C}$	1.1
	$\leq 40\text{ °C}$	1.25

Notes

- The maximum permitted gear unit temperature (see the "Other product features" chapter) must not be exceeded, as that could result in damage.
- For braking from full speed (for example, when the power fails or when setting up the machine), note the permitted gear unit feed forces (F_{f2acc} , F_{f2NOT}) in the selection tables.

3.6.2 Permitted breakdown torques at the gear unit input

For a horizontal mounting position of the motor, verify that the permitted breakdown torque at the gear unit input is not exceeded before installation on a STOBBER gear unit. You can find information for how to do that in this chapter.

Calculate the actual breakdown torque as follows:

$$M_{1k*} = F_{1k*} \cdot l_{sp} \leq M_{1k}$$

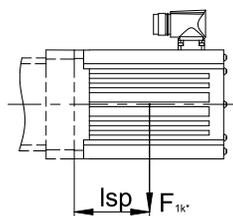

Type	M_{1k} [Nm]
PHQ431_ME	40
PHQ432_ME	20
PHQ531_ME	80
PHQ532_ME	40
PHQ731_ME	200
PHQ732_ME	80
PHQ733_ME	40
PHQ831_ME	400
PHQ832_ME	200
PHQ833_ME	80
PHQ942_ME	400
PHQ943_ME	200
PHQ1042_ME	800
PHQ1043_ME	400
PHQ1142_ME	1200
PHQ1143_ME	400
PHQ1242_ME	1800
PHQ1243_ME	800

The values also apply to the MEL and MF motor adapters.

3.6.3 Recommendation for radial shaft seal rings

For a duty cycle > 60% and higher surrounding temperatures, we recommend radial shaft seal rings made of FKM at the output.

Properties:

- Excellent temperature resistance
- High chemical stability
- Very good resistance to aging
- Excellent resistance in oils and greases
- For use in the food, beverage and pharmaceutical industries

Leak-proofness

Our gear units are equipped with high-quality radial shaft seal rings and checked for leaks. However, a leak cannot be fully ruled out over the length of use of a gear unit. If you use a gear unit with goods incompatible with the lubricant, you must take measures to prevent direct contact with the gear unit lubricant in case of a leak.

3.7 Additional documentation

Additional documentation related to the product can be found at <http://www.stoeber.de/en/downloads/>

Enter the ID of the documentation in the Search term field.

Documentation	ID
Operating manual gear units, geared motors PHQ43 – PHQ83, PHQ94 – PHQ124	443353_en
Operating manual gear racks	443392_en

4 ZTRSPHV rack and pinion drives

Table of contents

4.1	Overview	46
4.2	Selection tables	47
4.3	Dimensional drawings	48
4.4	Type designation	49
4.4.1	Nameplate	50
4.5	Product description	50
4.5.1	Input options	50
4.5.2	Motor adapter with EasyAdapt coupling (ME/MEL)	51
4.5.3	Gear rack	51
4.5.4	Installation conditions	51
4.5.5	Lubricants	51
4.5.6	Position of locking screw access	52
4.5.7	Other product features	52
4.5.8	Direction of rotation	52
4.6	Project configuration	52
4.6.1	Drive selection	53
4.6.2	Permitted breakdown torques at the gear unit input	55
4.6.3	Recommendation for radial shaft seal rings	55
4.7	Additional documentation	56

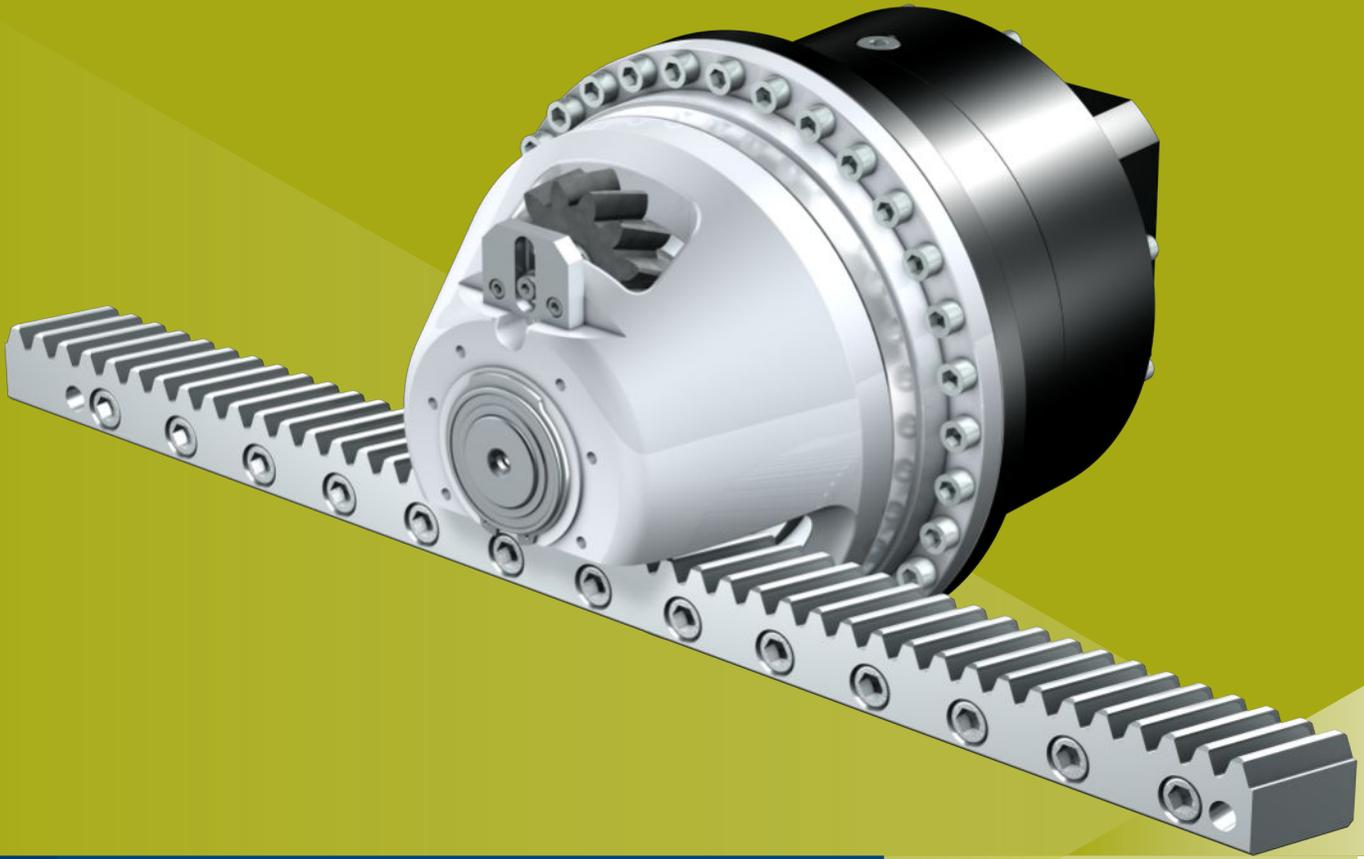

4 Rack and pinion drives

ZTRSPHV

4.1 Overview

High-performance precision planetary gear units with supporting bearing holder

Features

Power density	★★★★★
Linear clearance	★★★★☆
Price category	€€€€€
Smooth operation	★★★★☆
Linear rigidity	★★★★★
Mass moment of inertia	★★★★☆
Ready-to-install drive solution	✓
Pinion gearing quality 5 (DIN 3962)	✓
Helical gearing	✓
Case-hardened and smoothed	✓
Radial runout ≤ 10 μm (optional)	✓

Key ★☆☆☆☆ good | ★★★★★ excellent
 € Economy | €€€€€ Premium

Technical data

m_n	5 – 8 mm
z	15 – 20
F_{f2acc}	67 – 77 kN
$v_{f2maxZB}$	0.21 – 0.49 m/s
Δs	15 – 56 μm

4.2 Selection tables

The technical data specified in the selection tables applies to:

- De-energized installation
- Permanent lubrication with the lubricants recommended in the chapter on gear racks ▶ 13.5.1]
- Case-hardened pinions, helical (left-hand 19° 31' 42"), gearing quality 5
- Installation altitudes up to 1000 m above sea level
- Surrounding temperatures from 0 °C to 40 °C
- Without consideration of the thermal limiting performance

For all other technical data, refer to <https://configurator.stoeber.de/en-US/>.

An explanation of the formula symbols can be found in the chapter ▶ 14.1].

i	Type	$n_{1\max DB}$ [rpm]	$n_{1\max ZB}$ [rpm]	d_{MW} [mm]	$v_{f2\max ZB}$ [m/s]	Δs [μm]	Δs_{red} [μm]	C_{lin} [N/μm]	m_n [mm]	z	d_0 [mm]	F_{f2N} [kN]	F_{f2acc} [kN]	F_{f2NOT} [kN]	M_{2acc} [Nm]
ZTRS5PHV9 ($F_{f2acc,max} = 77$ kN)															
61.00	ZTRS520SPHV943_0610 ME	2500	4500	≤38	0.41	46	15	356	5	20	106.1	47	77	154	4075
61.00	ZTRS520SPHV943_0610 MEL	2500	4500	≤48	0.41	46	15	356	5	20	106.1	47	77	154	4075
91.00	ZTRS520SPHV943_0910 ME	2500	4500	≤38	0.28	46	15	355	5	20	106.1	47	77	154	4075
91.00	ZTRS520SPHV943_0910 MEL	2500	4500	≤48	0.28	46	15	355	5	20	106.1	47	77	154	4075
121.0	ZTRS520SPHV943_1210 ME	2500	4500	≤38	0.21	46	15	350	5	20	106.1	47	77	154	4075
121.0	ZTRS520SPHV943_1210 MEL	2500	4500	≤48	0.21	46	15	350	5	20	106.1	47	77	154	4075
ZTRS6PHV9 ($F_{f2acc,max} = 67$ kN)															
61.00	ZTRS620SPHV943_0610 ME	2500	4500	≤38	0.49	56	19	322	6	20	127.3	39	67	141	4250
61.00	ZTRS620SPHV943_0610 MEL	2500	4500	≤48	0.49	56	19	322	6	20	127.3	39	67	141	4250
91.00	ZTRS620SPHV943_0910 ME	2500	4500	≤38	0.33	56	19	320	6	20	127.3	39	67	141	4250
91.00	ZTRS620SPHV943_0910 MEL	2500	4500	≤48	0.33	56	19	320	6	20	127.3	39	67	141	4250
121.0	ZTRS620SPHV943_1210 ME	2500	4500	≤38	0.25	56	19	314	6	20	127.3	39	67	141	4250
121.0	ZTRS620SPHV943_1210 MEL	2500	4500	≤48	0.25	56	19	314	6	20	127.3	39	67	141	4250
ZTRS8PHV9 ($F_{f2acc,max} = 67$ kN)															
61.00	ZTRS815SPHV943_0610 ME	2500	4500	≤38	0.49	56	19	335	8	15	127.3	39	67	141	4250
61.00	ZTRS815SPHV943_0610 MEL	2500	4500	≤48	0.49	56	19	336	8	15	127.3	39	67	141	4250
91.00	ZTRS815SPHV943_0910 ME	2500	4500	≤38	0.33	56	19	334	8	15	127.3	39	67	141	4250
91.00	ZTRS815SPHV943_0910 MEL	2500	4500	≤48	0.33	56	19	334	8	15	127.3	39	67	141	4250
121.0	ZTRS815SPHV943_1210 ME	2500	4500	≤38	0.25	56	19	327	8	15	127.3	39	67	141	4250
121.0	ZTRS815SPHV943_1210 MEL	2500	4500	≤48	0.25	56	19	327	8	15	127.3	39	67	141	4250

4.3 Dimensional drawings

In this chapter, you can find the dimensions of the rack and pinion drives with motor adapter.

Dimension az in the tables of dimensions applies to STOEGER gear racks. In general: $az = \frac{1}{2} d_0 + h_0 + x \cdot mn$

The pinion of the rack and pinion drive is helical (left-hand $19^\circ 31' 42''$). The pinion gearing quality is 5.

Dimensions can exceed the specifications of ISO 2768-mK due to casting tolerances or accumulation of individual tolerances.

We reserve the right to make dimensional changes due to ongoing technical development.

You can download 3D models of our standard drives at <https://configurator.stoeber.de/en-US/>.

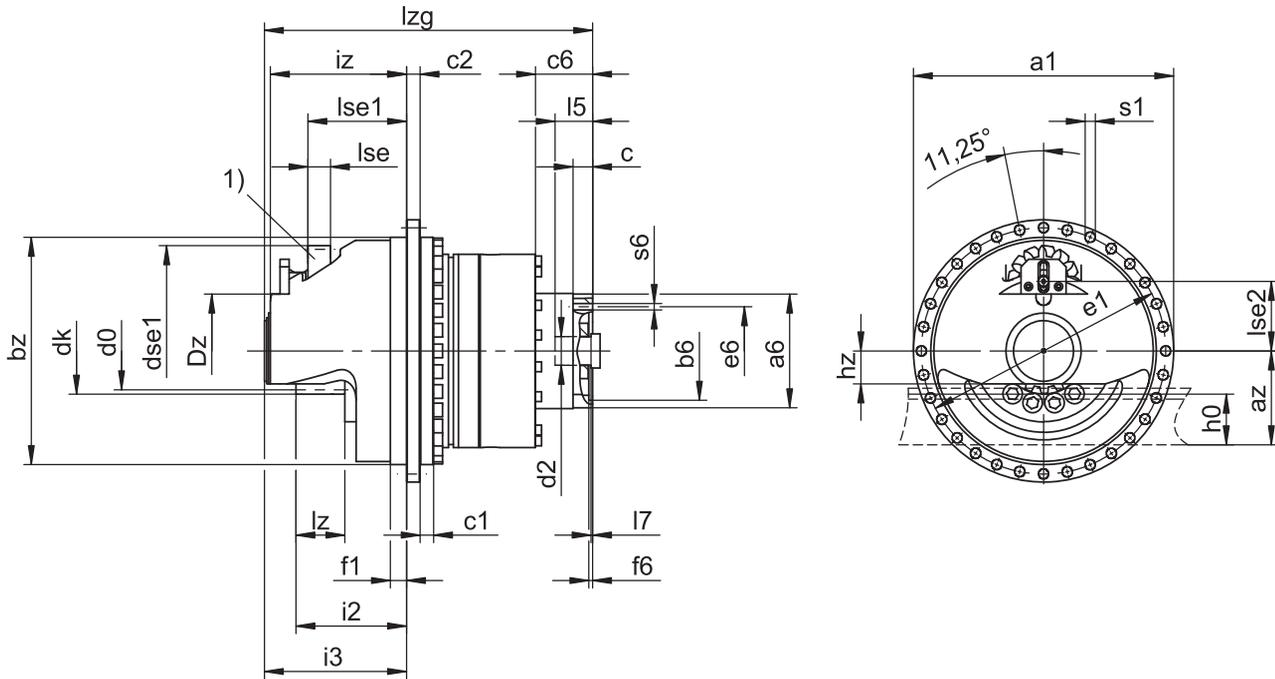

1) Felt gear for lubrication (option)

Output dimensions

Type	mn	Øa1	az	Øbz	c1	c2	d0	dk	dse1	Dz	Øe1	f1	i2	i3	iz	h0	hz	lz	lse	lse1	lse2	Øs1	x
ZTRS520SPHV9_	5	346	87.05	300 _{h7}	18	18	106.10	116.1	78.6	100	325	21.5	137.0	179.0	171.0	34	45.0	55	30	131.1	87.1	13.5	0.0
ZTRS620SPHV9_	6	346	106.66	300 _{h7}	18	18	127.32	139.3	94.2	100	325	21.5	147.0	189.0	181.0	43	43.5	65	30	131.1	104.8	13.5	0.0
ZTRS815SPHV9_	8	346	136.66	300 _{h7}	18	18	127.32	147.3	160.0	110	325	21.5	162.0	204.7	196.5	71	55.0	80	65	162.0	137.7	13.5	0.3

Example dimensions for the motor connection + total length

Type	Øb6	Øe6	Ød2max	l5	□a6	c	c6	f6	l7	lzg	s6
ZTRS5_PHV9_ME	130 ^{H7}	165	38	61	150	26	66	5.5	4.5	425.0	M10
ZTRS6_PHV9_ME	130 ^{H7}	165	38	61	150	26	66	5.5	4.5	435.0	M10
ZTRS8_PHV9_ME	130 ^{H7}	165	38	61	150	26	66	5.5	4.5	450.7	M10

In the table above, you will find example dimensions for the motor connection for the ME motor adapter.

Note that when dimension c is lengthened, dimensions c6, l5 and lzg are also lengthened accordingly.

You will find additional motor connection dimensions for motor adapters ME and MEL in our STOEGER Configurator at <https://configurator.stoeber.de/en-US/>. Here, you can directly download a 3D model of your drive.

4.4 Type designation

This chapter shows you an explanation of the type designation with the associated options.

Additional ordering information not included in the type designation can be found at the end of the chapter.

Example code

Z	TRS	6	20	S	PHV	9	4	3	S	F	S	S	0910	ME
---	-----	---	----	---	-----	---	---	---	---	---	---	---	------	----

Explanation

Code	Designation	Design
Z	Type	Rack and pinion drive
TRS	Design	Screwed flange pinion with supporting bearing holder
6	Normal module	$m_n = 6$ mm (example)
20	Number of teeth	$z = 20$ (example)
S	Toothing	Helical (left-hand 19° 31' 42")
SF		Helical (left-hand 19° 31' 42") with felt gear for lubrication
PHV	Type	Planetary gear unit
9	Size	9 (example)
4	Generation	Generation 4
3	Stages	Three-stage
S	Housing	Standard
F	Shaft	Flange shaft
S	Bearing	Standard bearing
S	Backlash	Standard
R		Reduced (PHV9)
0910	Transmission ratio ($i \times 10$)	$i = 91$ (example)
ME	Motor adapter	Motor adapter with EasyAdapt coupling
MEL		Motor adapter with EasyAdapt coupling for large motors
MB ¹		ServoStop motor adapter with brake

To complete the type designation, also specify the following in your order:

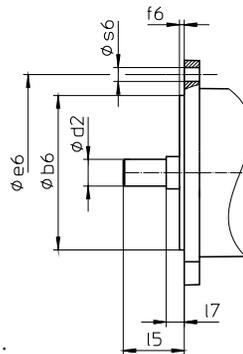

- Motor type or motor dimensions:

To choose a suitable motor connection, use the STOEGER Configurator at

<https://configurator.stoeber.de/en-US/> and choose your motor or the dimensions of the motor connection.

- Position of the gear rack, see the chapter [▶ 4.5.6]
- Radial shaft seal rings at the output made of NBR or FKM (option), see the chapter [▶ 4.6.3]
- Radial runout $\leq 10 \mu\text{m}$ (optional)
- Reverse operation of the output shaft from $\pm 20^\circ$ to $\pm 90^\circ$ for horizontal installation on request
- Double seal for motor adapter (option)
- Socket wrench insert for mounting the motor on the gear unit using the ME/MEL motor adapter (optional)

In this product catalog, you will find all the information about rack and pinion drives with a motor adapter. All input options available upon request are listed in the chapter [▶ 4.5.1].

¹You can find more details in the catalog for ServoStop servo gear unit with brake ID 443234.

4.4.1 Nameplate

An example gear unit nameplate is explained in the figure below.

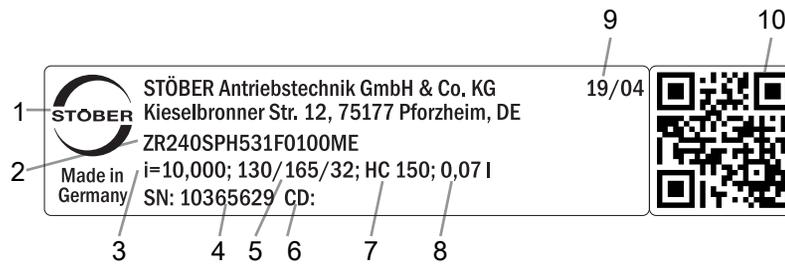

Code	Designation
1	Name of manufacturer
2	Type designation
3	Gear ratio of the gear unit
4	Serial number of the gear unit
5	Dimensions of the motor adapter (pilot/bolt circle/motor shaft diameter)
6	Customer-specific data
7	Lubricant specification
8	Lubricant fill volume
9	Date of manufacture (year/calendar week)
10	QR code (link to product information)

4.4.1.1 Supporting documents

You can view or download supporting documents for the product by reading off the serial number on the nameplate of the product and entering it at the following address online:

<https://id.stober.com>

Alternatively, you can use a suitable mobile device to scan in the QR code on the nameplate of the product in order to be linked to the supporting documents.

4.5 Product description

4.5.1 Input options

In this chapter, you will find all available input options:

Motor adapter



Catalog ID 443137_en

EZ synchronous servo motor



Catalog ID 443286_en

The corresponding catalogs can be found at <http://www.stober.de/en/downloads/>

Enter the ID of the catalog in the Search term field.

4.5.2 Motor adapter with EasyAdapt coupling (ME/MEL)

In this chapter, you will find a description of the EasyAdapt coupling.

Properties:

- Fast and easy motor attachment
- One-piece, rugged clamp coupling with expanding function
- Lowest mass moments of inertia for the highest dynamics
- Balanced for smooth running without vibration, even at high speeds
- Large selection of motor shaft diameters and lengths
- Error-free, thanks to exact centering of the motor
- For reduced backlash, the motor shaft bearing must have an axially backlash-free design



Fig. 1: EasyAdapt coupling

4.5.3 Gear rack

The gear rack used must have a right-hand design (19° 31' 42"); the load capacity must not be exceeded.

When using a STOBBER gear rack, please also observe the project configuration in the chapter [\[▶ 13.6\]](#).

4.5.4 Installation conditions

The torque and force values listed in this catalog are valid under the following conditions:

- When the gear housing is fastened on the machine side using screws of strength class 12.9
- When the gear housings are adjusted at pilot \varnothing bz. The machine-side fit must be H7.

4.5.5 Lubricants

STOBBER fills the gear units with the amount and type of lubricant specified on the nameplate.

You will receive lubricants for use in the food industry upon request.

4.5.5.1 Rack and pinion drive lubrication

Ensure permanent lubrication with the lubricants recommended in the chapter [\[▶ 13.5.1\]](#).

4.5.6 Position of locking screw access

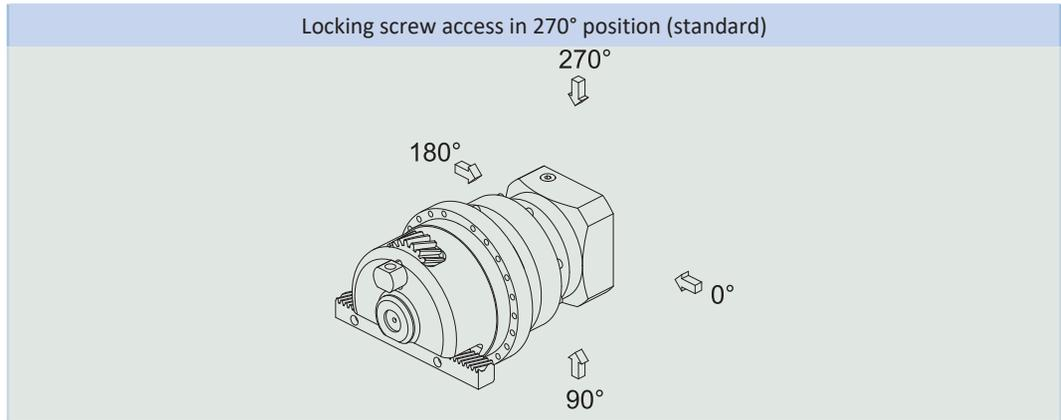

The access hole for the motor coupling locking screw in the standard version is in the 270° position. Indicate variations for your rack and pinion drive in the order.

Note that the access hole for the motor coupling locking screw also rotates when the gear rack is rotated to another position.

4.5.7 Other product features

Feature	Value
Max. permitted gear unit temperature (on the surface of the gear unit)	≤ 90 °C
Paint	Black RAL 9005
(ATEX) Directive 2014/34/EU (optional)	Not suitable.
Protection class: ²	
Planetary gear unit	IP65
Pinion/gear rack	IPXX

4.5.8 Direction of rotation

The input and output rotate in the same direction.

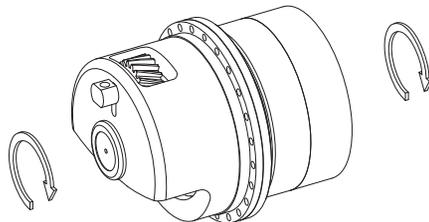

4.6 Project configuration

Project your drives using our SERVOSOFT designing software. Download SERVOSOFT free of charge after registration at <https://www.stoeber.de/en/services/info-servosoft/>.

It is the most convenient and reliable method of drive selection, as the entire torque/speed curve of the application is displayed and evaluated here in the curve of the geared motor.

In this chapter, only limit values for specific operating points can be taken into consideration for manual drive selection.

The formula symbols for values actually present in the application are marked with *.

An explanation of the formula symbols can be found in the chapter [▶ 14.1](#).

4.6.1 Drive selection

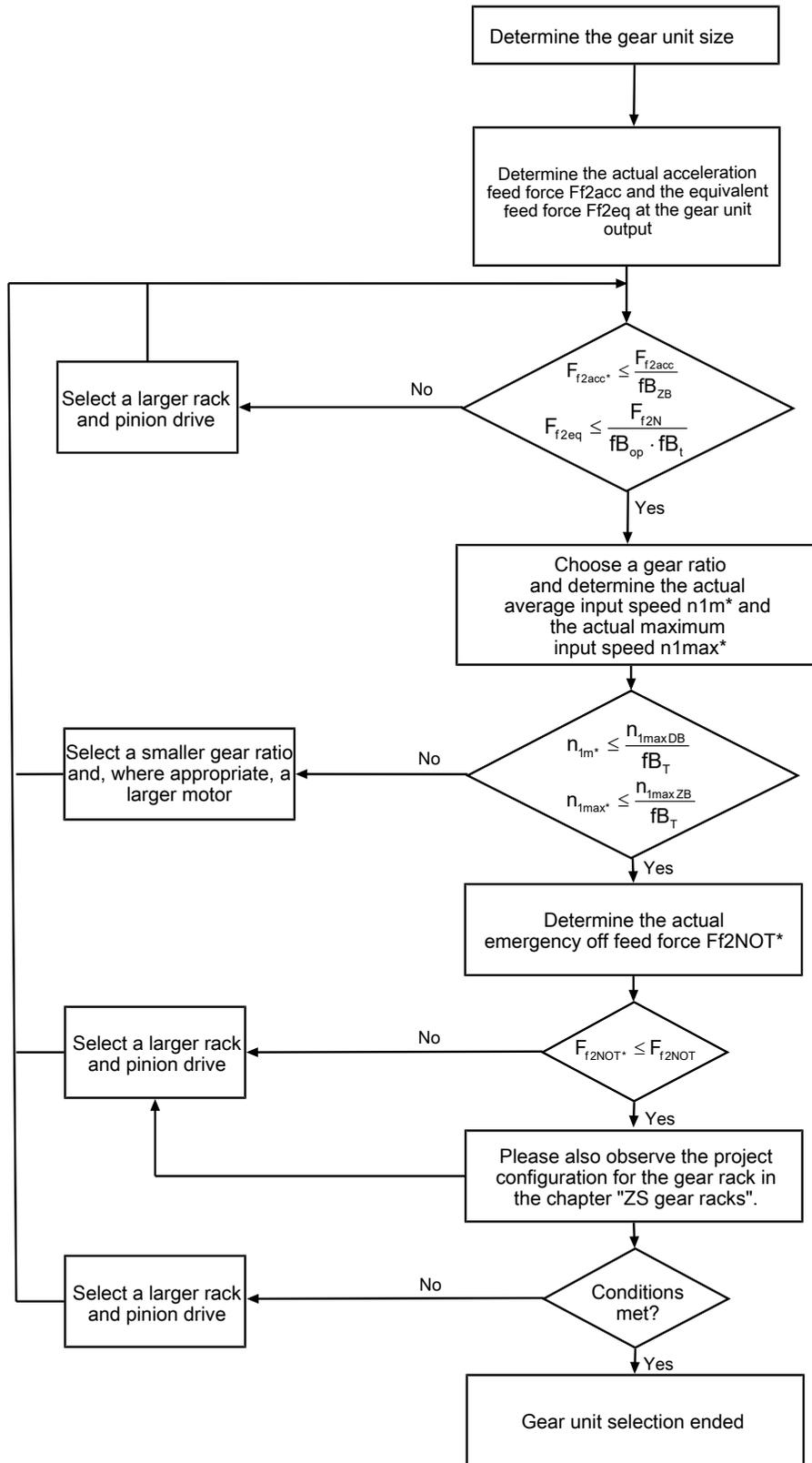

Refer to the selection tables for the values for i , n_{1maxDB} , n_{1maxZB} , F_{f2acc} , F_{f2N} and F_{f2NOT} .

The values for f_{B_T} , $f_{B_{op}}$, f_{B_t} and $f_{B_{zB}}$ can be found in the corresponding tables in this chapter.

Example of cyclic operation

The following calculations are based on a representation of the power taken from the output based in accordance with the following example:

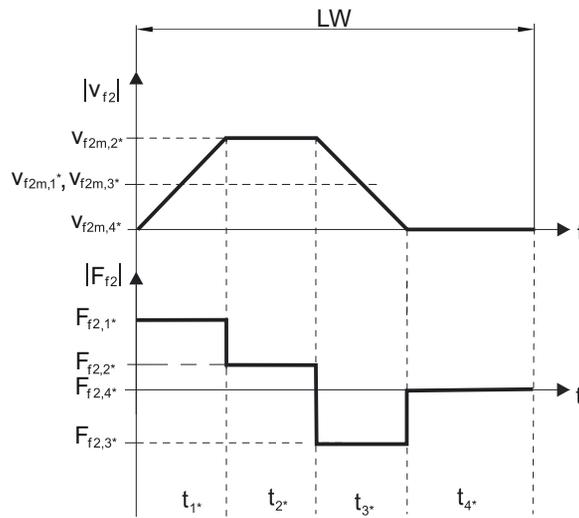

Calculation of the actual maximum acceleration feed force

$$F_{f2acc*} = m \cdot a^* + F_{L*}$$

Calculation of the actual average input speed

$$n_{1m*} = \frac{v_{f2m*} \cdot i}{d_0 \cdot \pi}$$

$$v_{f2m*} = \frac{|v_{f2m,1*}| \cdot t_{1*} + \dots + |v_{f2m,n*}| \cdot t_{n*}}{t_{1*} + \dots + t_{n*}}$$

If $t_{1*} + \dots + t_{3*} \geq 6$ min, determine v_{2m*} without the rest phase t_{4*} .

The values for the ratio i can be found in the selection tables.

Calculation of the actual emergency off feed force

$$F_{f2NOT*} = m \cdot a_{NOT*} + F_{L*}$$

Calculation of the actual equivalent feed force

$$F_{f2eq*} = \sqrt[3]{\frac{|v_{f2m,1*}| \cdot t_{1*} \cdot |F_{f2,1*}|^3 + \dots + |v_{f2m,n*}| \cdot t_{n*} \cdot |F_{f2,n*}|^3}{|v_{f2m,1*}| \cdot t_{1*} + \dots + |v_{f2m,n*}| \cdot t_{n*}}}$$

Operating factors

Operating mode	fB_{op}
Uniform continuous operation	1.00
Cyclic operation	1.00
Reversing load cyclic operation	1.00
Run time	fB_t
Daily runtime ≤ 8 h	1.00
Daily runtime ≤ 16 h	1.15
Daily runtime ≤ 24 h	1.20
Cyclic operation	fB_{ZB}
≤ 1000 load changes/hour (LW/h)	1.00
> 1000 load changes/hour (LW/h)	1.15

Temperature		f_{B_T}
Motor cooling	Surrounding temperature	
Motor with forced ventilation	$\leq 20\text{ °C}$	0.9
	$\leq 30\text{ °C}$	1.0
	$\leq 40\text{ °C}$	1.15
Motor with convection cooling	$\leq 20\text{ °C}$	1.0
	$\leq 30\text{ °C}$	1.1
	$\leq 40\text{ °C}$	1.25

Notes

- The maximum permitted gear unit temperature (see the "Other product features" chapter) must not be exceeded, as that could result in damage.
- For braking from full speed (for example, when the power fails or when setting up the machine), note the permitted gear unit feed forces (F_{f2acc} , F_{f2NOT}) in the selection tables.

4.6.2 Permitted breakdown torques at the gear unit input

For a horizontal mounting position of the motor, verify that the permitted breakdown torque at the gear unit input is not exceeded before installation on a STOBBER gear unit. You can find information for how to do that in this chapter.

Calculate the actual breakdown torque as follows:

$$M_{1k^*} = F_{1k^*} \cdot l_{sp} \leq M_{1k}$$

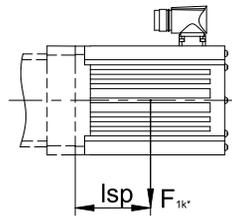

Type	M_{1k} [Nm]
PHV943_ME	200
PHV1043_ME	400

The values also apply to the MEL motor adapter.

4.6.3 Recommendation for radial shaft seal rings

For a duty cycle > 60% and higher surrounding temperatures, we recommend radial shaft seal rings made of FKM at the output.

Properties:

- Excellent temperature resistance
- High chemical stability
- Very good resistance to aging
- Excellent resistance in oils and greases
- For use in the food, beverage and pharmaceutical industries

Leak-proofness

Our gear units are equipped with high-quality radial shaft seal rings and checked for leaks. However, a leak cannot be fully ruled out over the length of use of a gear unit. If you use a gear unit with goods incompatible with the lubricant, you must take measures to prevent direct contact with the gear unit lubricant in case of a leak.

4.7 Additional documentation

Additional documentation related to the product can be found at

<http://www.stoeber.de/en/downloads/>

Enter the ID of the documentation in the Search term field.

Documentation	ID
Operating manual gear units, geared motors PHV94 – PHV104	443355_en
Operating manual gear racks	443392_en

5 ZTRPH rack and pinion drives

Table of contents

5.1	Overview	58
5.2	Selection tables	59
5.3	Dimensional drawings	66
5.4	Type designation	68
5.4.1	Nameplate	69
5.5	Product description	69
5.5.1	Input options	69
5.5.2	Motor adapter with EasyAdapt coupling (ME/MEL)	70
5.5.3	Motor adapter with FlexiAdapt coupling (MF)	70
5.5.4	Gear rack	71
5.5.5	Installation conditions	71
5.5.6	Lubricants	71
5.5.7	Other product features	71
5.5.8	Direction of rotation	71
5.6	Project configuration	72
5.6.1	Drive selection	73
5.6.2	Permitted breakdown torques at the gear unit input	75
5.6.3	Recommendation for radial shaft seal rings	75
5.7	Additional documentation	76

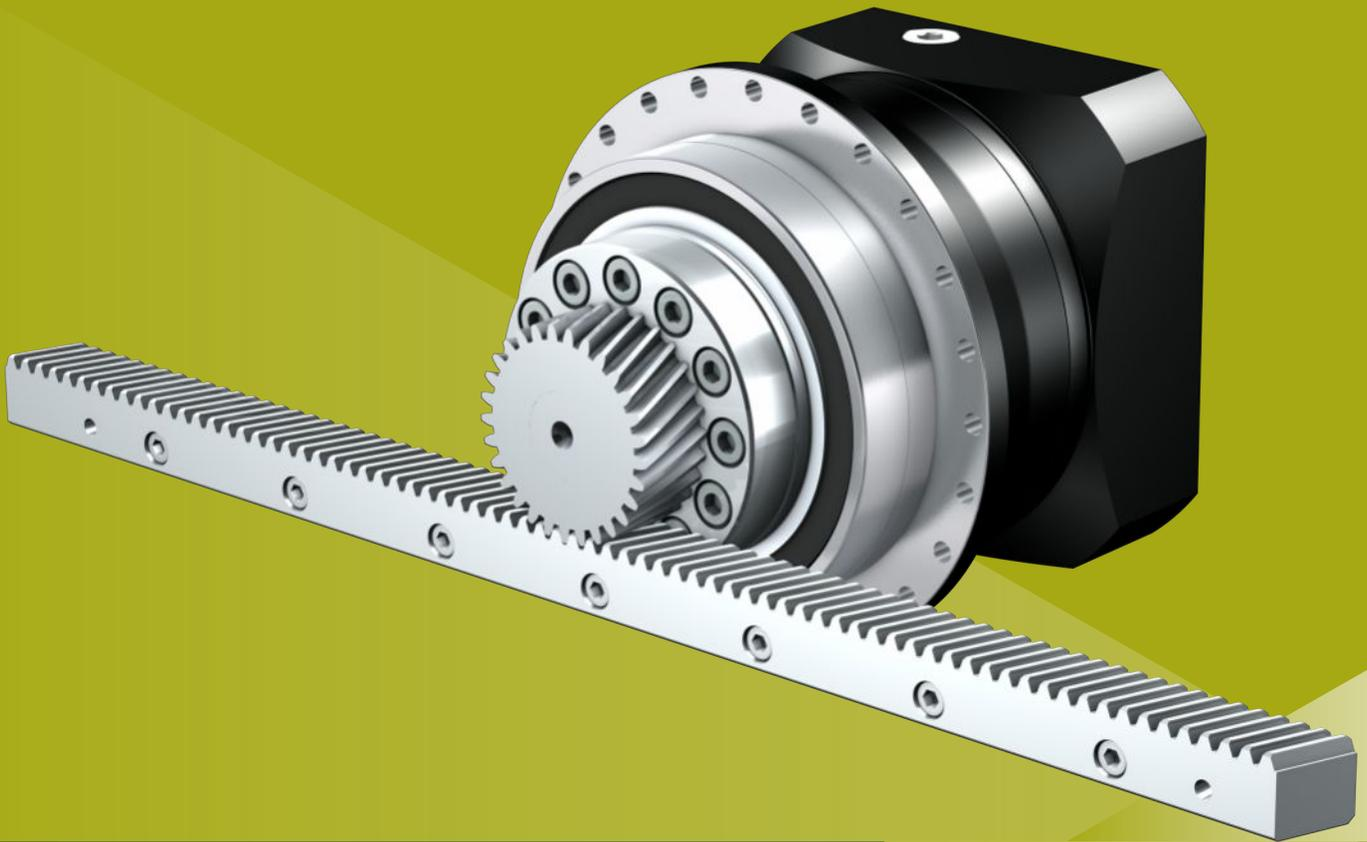

5 Rack and pinion drives

ZTRPH

5.1 Overview

High-performance precision planetary gear units with screwed flange pinion

Features

Power density	★★★★☆
Linear clearance	★★★★★
Price category	€€€€
Smooth operation	★★★★☆
Linear rigidity	★★★★☆
Mass moment of inertia	★★★★☆
Ready-to-install drive solution	✓
Pinion gearing quality 5 (DIN 3962)	✓
Helical gearing	✓
Case-hardened and smoothed	✓
Radial runout $\leq 10 \mu\text{m}$ (optional)	✓
Reinforced output bearing (PH3 – PH5)	✓ (optional)

Key ★☆☆☆☆ good | ★★★★★ excellent
 € Economy | €€€€€ Premium

Technical data

m_n	2 – 6 mm
z	12 – 32
F_{f2acc}	6.5 – 67 kN
$V_{f2maxZB}$	0.11 – 4.7 m/s
Δs	4 – 44 μm

5.2 Selection tables

The technical data specified in the selection tables applies to:

- De-energized installation
- Permanent lubrication with the lubricants recommended in the chapter on gear racks ▶ 13.5.1]
- Case-hardened pinions, helical (left-hand 19° 31' 42"), gearing quality 5
- Installation altitudes up to 1000 m above sea level
- Surrounding temperatures from 0 °C to 40 °C
- Without consideration of the thermal limiting performance

For rack and pinion drives with reduced backlash or reinforced bearings (PH3 – PH5), higher feed forces are possible. For this and all other technical data, refer to <https://configurator.stoeber.de/en-US/>.

An explanation of the formula symbols can be found in the chapter ▶ 14.1].

i	Type	$n_{1\max\text{DB}}$ [rpm]	$n_{1\max\text{ZB}}$ [rpm]	d_{MW} [mm]	$v_{f2\max\text{ZB}}$ [m/s]	Δs [μm]	Δs_{red} [μm]	C_{lin} [N/μm]	m_n [mm]	z	d_0 [mm]	F_{f2N} [kN]	$F_{f2\text{acc}}$ [kN]	$F_{f2\text{NOT}}$ [kN]	$M_{2\text{acc}}$ [Nm]
ZTR2PH4 ($F_{f2\text{acc,max}} = 6,7 \text{ kN}$)															
4.000	ZTR212SPH431_0040 ME	2600	5000	≤24	1.67	11	4	98	2	12	25.5	2.3	6.7	11	85
4.000	ZTR212SPH431_0040 MEL	2600	5000	≤32	1.67	11	4	98	2	12	25.5	2.3	6.7	11	85
4.000	ZTR216SPH431_0040 ME	2600	5000	≤24	2.22	15	5	93	2	16	34.0	2.3	6.7	9.2	114
4.000	ZTR216SPH431_0040 MEL	2600	5000	≤32	2.22	15	5	93	2	16	34.0	2.3	6.7	9.2	114
5.000	ZTR212SPH431_0050 ME	3000	6000	≤24	1.60	11	4	98	2	12	25.5	2.4	6.7	11	85
5.000	ZTR212SPH431_0050 MEL	3000	6000	≤32	1.60	11	4	98	2	12	25.5	2.4	6.7	11	85
5.000	ZTR216SPH431_0050 ME	3000	6000	≤24	2.13	15	5	92	2	16	34.0	2.4	6.7	9.2	114
5.000	ZTR216SPH431_0050 MEL	3000	6000	≤32	2.13	15	5	92	2	16	34.0	2.4	6.7	9.2	114
7.000	ZTR212SPH431_0070 ME	3200	6000	≤24	1.14	11	4	96	2	12	25.5	2.7	6.7	11	85
7.000	ZTR212SPH431_0070 MEL	3200	6000	≤32	1.14	11	4	96	2	12	25.5	2.7	6.7	11	85
7.000	ZTR216SPH431_0070 ME	3200	6000	≤24	1.52	15	5	89	2	16	34.0	2.7	6.7	9.2	114
7.000	ZTR216SPH431_0070 MEL	3200	6000	≤32	1.52	15	5	89	2	16	34.0	2.7	6.7	9.2	114
10.00	ZTR212SPH431_0100 ME	3500	7000	≤24	0.93	11	4	90	2	12	25.5	3.1	6.7	11	85
10.00	ZTR212SPH431_0100 MEL	3500	7000	≤32	0.93	11	4	90	2	12	25.5	3.1	6.7	11	85
10.00	ZTR216SPH431_0100 ME	3500	7000	≤24	1.24	15	5	81	2	16	34.0	3.1	6.7	9.2	114
10.00	ZTR216SPH431_0100 MEL	3500	7000	≤32	1.24	15	5	81	2	16	34.0	3.1	6.7	9.2	114
16.00	ZTR212SPH432_0160 ME	4000	8000	≤19	0.67	11	4	96	2	12	25.5	3.6	6.7	11	85
16.00	ZTR212SPH432_0160 MEL	4000	8000	≤24	0.67	11	4	96	2	12	25.5	3.6	6.7	11	85
16.00	ZTR216SPH432_0160 ME	4000	8000	≤19	0.89	15	5	89	2	16	34.0	3.6	6.7	9.2	114
16.00	ZTR216SPH432_0160 MEL	4000	8000	≤24	0.89	15	5	89	2	16	34.0	3.6	6.7	9.2	114
20.00	ZTR212SPH432_0200 ME	4000	8000	≤19	0.53	11	4	96	2	12	25.5	3.9	6.7	11	85
20.00	ZTR212SPH432_0200 MEL	4000	8000	≤24	0.53	11	4	96	2	12	25.5	3.9	6.7	11	85
20.00	ZTR216SPH432_0200 ME	4000	8000	≤19	0.71	15	5	90	2	16	34.0	3.9	6.7	9.2	114
20.00	ZTR216SPH432_0200 MEL	4000	8000	≤24	0.71	15	5	90	2	16	34.0	3.9	6.7	9.2	114
25.00	ZTR212SPH432_0250 ME	4500	8000	≤19	0.43	11	4	97	2	12	25.5	4.2	6.7	11	85
25.00	ZTR212SPH432_0250 MEL	4500	8000	≤24	0.43	11	4	97	2	12	25.5	4.2	6.7	11	85
25.00	ZTR216SPH432_0250 ME	4500	8000	≤19	0.57	15	5	91	2	16	34.0	4.2	6.7	9.2	114
25.00	ZTR216SPH432_0250 MEL	4500	8000	≤24	0.57	15	5	91	2	16	34.0	4.2	6.7	9.2	114
28.00	ZTR212SPH432_0280 ME	4500	8000	≤19	0.38	11	4	96	2	12	25.5	4.2	6.7	11	85
28.00	ZTR212SPH432_0280 MEL	4500	8000	≤24	0.38	11	4	96	2	12	25.5	4.2	6.7	11	85
28.00	ZTR216SPH432_0280 ME	4500	8000	≤19	0.51	15	5	90	2	16	34.0	4.2	6.7	9.2	114
28.00	ZTR216SPH432_0280 MEL	4500	8000	≤24	0.51	15	5	90	2	16	34.0	4.2	6.7	9.2	114
35.00	ZTR212SPH432_0350 ME	4500	8000	≤19	0.31	11	4	97	2	12	25.5	4.2	6.7	11	85
35.00	ZTR212SPH432_0350 MEL	4500	8000	≤24	0.31	11	4	97	2	12	25.5	4.2	6.7	11	85
35.00	ZTR216SPH432_0350 ME	4500	8000	≤19	0.41	15	5	90	2	16	34.0	4.2	6.7	9.2	114
35.00	ZTR216SPH432_0350 MEL	4500	8000	≤24	0.41	15	5	90	2	16	34.0	4.2	6.7	9.2	114
40.00	ZTR212SPH432_0400 ME	4500	8000	≤19	0.27	11	4	96	2	12	25.5	4.2	6.7	11	85
40.00	ZTR212SPH432_0400 MEL	4500	8000	≤24	0.27	11	4	96	2	12	25.5	4.2	6.7	11	85
40.00	ZTR216SPH432_0400 ME	4500	8000	≤19	0.36	15	5	89	2	16	34.0	4.2	6.7	9.2	114
40.00	ZTR216SPH432_0400 MEL	4500	8000	≤24	0.36	15	5	89	2	16	34.0	4.2	6.7	9.2	114
50.00	ZTR212SPH432_0500 ME	4500	8000	≤19	0.21	11	4	96	2	12	25.5	4.2	6.7	11	85
50.00	ZTR212SPH432_0500 MEL	4500	8000	≤24	0.21	11	4	96	2	12	25.5	4.2	6.7	11	85
50.00	ZTR216SPH432_0500 ME	4500	8000	≤19	0.28	15	5	90	2	16	34.0	4.2	6.7	9.2	114
50.00	ZTR216SPH432_0500 MEL	4500	8000	≤24	0.28	15	5	90	2	16	34.0	4.2	6.7	9.2	114
70.00	ZTR212SPH432_0700 ME	4500	8000	≤19	0.15	11	4	94	2	12	25.5	4.2	6.7	11	85
70.00	ZTR212SPH432_0700 MEL	4500	8000	≤24	0.15	11	4	94	2	12	25.5	4.2	6.7	11	85
70.00	ZTR216SPH432_0700 ME	4500	8000	≤19	0.20	15	5	87	2	16	34.0	4.2	6.7	9.2	114
70.00	ZTR216SPH432_0700 MEL	4500	8000	≤24	0.20	15	5	87	2	16	34.0	4.2	6.7	9.2	114
100.0	ZTR212SPH432_1000 ME	4500	8000	≤19	0.11	11	4	89	2	12	25.5	4.2	6.7	11	85
100.0	ZTR212SPH432_1000 MEL	4500	8000	≤24	0.11	11	4	89	2	12	25.5	4.2	6.7	11	85

5.2 Selection tables 5 ZTRPH rack and pinion drives

i	Type	n_{1maxDB}	n_{1maxZB}	d_{MW}	$v_{f2maxZB}$	Δs	Δs_{red}	C_{lin}	m_n	z	d_0	F_{f2N}	F_{f2acc}	F_{f2NOT}	M_{2acc}
		[rpm]	[rpm]	[mm]	[m/s]	[μm]	[μm]	[N/ μm]	[mm]		[mm]	[kN]	[kN]	[kN]	[Nm]
ZTR2PH4 ($F_{f2acc,max} = 6,7$ kN)															
100.0	ZTR216SPH432_1000 ME	4500	8000	≤ 19	0.14	15	5	79	2	16	34.0	4.2	6.5	9.2	110
100.0	ZTR216SPH432_1000 MEL	4500	8000	≤ 24	0.14	15	5	79	2	16	34.0	4.2	6.5	9.2	110
ZTR2PH5 ($F_{f2acc,max} = 11$ kN)															
4.000	ZTR219SPH531_0040 ME	2200	5000	≤ 32	2.64	18	6	94	2	19	40.3	3.3	10	15	210
4.000	ZTR219SPH531_0040 MEL	2200	5000	≤ 38	2.64	18	6	94	2	19	40.3	3.3	10	15	210
4.000	ZTR223SPH531_0040 ME	2200	5000	≤ 32	3.19	21	7	91	2	23	48.8	3.3	11	14	259
4.000	ZTR223SPH531_0040 MEL	2200	5000	≤ 38	3.19	21	7	91	2	23	48.8	3.3	11	14	259
5.000	ZTR219SPH531_0050 ME	2500	5500	≤ 32	2.32	18	6	94	2	19	40.3	3.6	10	15	210
5.000	ZTR219SPH531_0050 MEL	2500	5500	≤ 38	2.32	18	6	94	2	19	40.3	3.6	10	15	210
5.000	ZTR223SPH531_0050 ME	2500	5500	≤ 32	2.81	21	7	91	2	23	48.8	3.6	11	14	259
5.000	ZTR223SPH531_0050 MEL	2500	5500	≤ 38	2.81	21	7	91	2	23	48.8	3.6	11	14	259
7.000	ZTR219SPH531_0070 ME	3000	6000	≤ 32	1.81	18	6	92	2	19	40.3	4.0	10	15	210
7.000	ZTR219SPH531_0070 MEL	3000	6000	≤ 38	1.81	18	6	92	2	19	40.3	4.0	10	15	210
7.000	ZTR223SPH531_0070 ME	3000	6000	≤ 32	2.19	21	7	87	2	23	48.8	4.0	11	14	259
7.000	ZTR223SPH531_0070 MEL	3000	6000	≤ 38	2.19	21	7	87	2	23	48.8	4.0	11	14	259
10.000	ZTR219SPH531_0100 ME	3300	6500	≤ 32	1.37	18	6	87	2	19	40.3	4.5	10	15	210
10.000	ZTR219SPH531_0100 MEL	3300	6500	≤ 38	1.37	18	6	87	2	19	40.3	4.5	10	15	210
10.000	ZTR223SPH531_0100 ME	3300	6500	≤ 32	1.66	21	7	81	2	23	48.8	4.5	11	14	259
10.000	ZTR223SPH531_0100 MEL	3300	6500	≤ 38	1.66	21	7	81	2	23	48.8	4.5	11	14	259
16.000	ZTR219SPH532_0160 ME	3500	7000	≤ 24	0.92	18	6	93	2	19	40.3	5.3	10	15	210
16.000	ZTR219SPH532_0160 MEL	3500	7000	≤ 32	0.92	18	6	93	2	19	40.3	5.3	10	15	210
16.000	ZTR223SPH532_0160 ME	3500	7000	≤ 24	1.12	21	7	89	2	23	48.8	5.3	11	14	259
16.000	ZTR223SPH532_0160 MEL	3500	7000	≤ 32	1.12	21	7	89	2	23	48.8	5.3	11	14	259
20.000	ZTR219SPH532_0200 ME	3500	7000	≤ 24	0.74	18	6	93	2	19	40.3	5.7	10	15	210
20.000	ZTR219SPH532_0200 MEL	3500	7000	≤ 32	0.74	18	6	93	2	19	40.3	5.7	10	15	210
20.000	ZTR223SPH532_0200 ME	3500	7000	≤ 24	0.89	21	7	90	2	23	48.8	5.7	11	14	259
20.000	ZTR223SPH532_0200 MEL	3500	7000	≤ 32	0.89	21	7	90	2	23	48.8	5.7	11	14	259
25.000	ZTR219SPH532_0250 ME	3700	7500	≤ 24	0.63	18	6	93	2	19	40.3	6.1	10	15	210
25.000	ZTR219SPH532_0250 MEL	3700	7500	≤ 32	0.63	18	6	93	2	19	40.3	6.1	10	15	210
25.000	ZTR223SPH532_0250 ME	3700	7500	≤ 24	0.77	21	7	89	2	23	48.8	6.1	11	14	259
25.000	ZTR223SPH532_0250 MEL	3700	7500	≤ 32	0.77	21	7	89	2	23	48.8	6.1	11	14	259
28.000	ZTR219SPH532_0280 ME	4000	8000	≤ 24	0.60	18	6	92	2	19	40.3	6.1	10	15	210
28.000	ZTR219SPH532_0280 MEL	4000	8000	≤ 32	0.60	18	6	92	2	19	40.3	6.1	10	15	210
28.000	ZTR223SPH532_0280 ME	4000	8000	≤ 24	0.73	21	7	88	2	23	48.8	6.1	11	14	259
28.000	ZTR223SPH532_0280 MEL	4000	8000	≤ 32	0.73	21	7	88	2	23	48.8	6.1	11	14	259
35.000	ZTR219SPH532_0350 ME	4000	8000	≤ 24	0.48	18	6	93	2	19	40.3	6.1	10	15	210
35.000	ZTR219SPH532_0350 MEL	4000	8000	≤ 32	0.48	18	6	93	2	19	40.3	6.1	10	15	210
35.000	ZTR223SPH532_0350 ME	4000	8000	≤ 24	0.58	21	7	89	2	23	48.8	6.1	11	14	259
35.000	ZTR223SPH532_0350 MEL	4000	8000	≤ 32	0.58	21	7	89	2	23	48.8	6.1	11	14	259
40.000	ZTR219SPH532_0400 ME	4000	8000	≤ 24	0.42	18	6	92	2	19	40.3	6.1	10	15	210
40.000	ZTR219SPH532_0400 MEL	4000	8000	≤ 32	0.42	18	6	92	2	19	40.3	6.1	10	15	210
40.000	ZTR223SPH532_0400 ME	4000	8000	≤ 24	0.51	21	7	87	2	23	48.8	6.1	11	14	259
40.000	ZTR223SPH532_0400 MEL	4000	8000	≤ 32	0.51	21	7	87	2	23	48.8	6.1	11	14	259
50.000	ZTR219SPH532_0500 ME	4000	8000	≤ 24	0.34	18	6	92	2	19	40.3	6.1	10	15	210
50.000	ZTR219SPH532_0500 MEL	4000	8000	≤ 32	0.34	18	6	92	2	19	40.3	6.1	10	15	210
50.000	ZTR223SPH532_0500 ME	4000	8000	≤ 24	0.41	21	7	88	2	23	48.8	6.1	11	14	259
50.000	ZTR223SPH532_0500 MEL	4000	8000	≤ 32	0.41	21	7	88	2	23	48.8	6.1	11	14	259
70.000	ZTR219SPH532_0700 ME	4000	8000	≤ 24	0.24	18	6	91	2	19	40.3	6.1	10	15	210
70.000	ZTR219SPH532_0700 MEL	4000	8000	≤ 32	0.24	18	6	91	2	19	40.3	6.1	10	15	210
70.000	ZTR223SPH532_0700 ME	4000	8000	≤ 24	0.29	21	7	86	2	23	48.8	6.1	11	14	259
70.000	ZTR223SPH532_0700 MEL	4000	8000	≤ 32	0.29	21	7	86	2	23	48.8	6.1	11	14	259
100.0	ZTR219SPH532_1000 ME	4000	8000	≤ 24	0.17	18	6	86	2	19	40.3	6.1	10	15	210
100.0	ZTR219SPH532_1000 MEL	4000	8000	≤ 32	0.17	18	6	86	2	19	40.3	6.1	10	15	210
100.0	ZTR223SPH532_1000 ME	4000	8000	≤ 24	0.20	21	7	80	2	23	48.8	6.1	11	14	259
100.0	ZTR223SPH532_1000 MEL	4000	8000	≤ 32	0.20	21	7	80	2	23	48.8	6.1	11	14	259
ZTR3PH5 ($F_{f2acc,max} = 9,9$ kN)															
4.000	ZTR314SPH531_0040 ME	2200	5000	≤ 32	2.92	19	6	88	3	14	44.6	3.3	9.9	14	221
4.000	ZTR314SPH531_0040 MEL	2200	5000	≤ 38	2.92	19	6	88	3	14	44.6	3.3	9.9	14	221
5.000	ZTR314SPH531_0050 ME	2500	5500	≤ 32	2.57	19	6	88	3	14	44.6	3.5	9.9	14	221
5.000	ZTR314SPH531_0050 MEL	2500	5500	≤ 38	2.57	19	6	88	3	14	44.6	3.5	9.9	14	221
7.000	ZTR314SPH531_0070 ME	3000	6000	≤ 32	2.00	19	6	85	3	14	44.6	3.9	9.9	14	221
7.000	ZTR314SPH531_0070 MEL	3000	6000	≤ 38	2.00	19	6	85	3	14	44.6	3.9	9.9	14	221
10.000	ZTR314SPH531_0100 ME	3300	6500	≤ 32	1.52	19	6	80	3	14	44.6	4.4	9.9	14	221
10.000	ZTR314SPH531_0100 MEL	3300	6500	≤ 38	1.52	19	6	80	3	14	44.6	4.4	9.9	14	221
16.000	ZTR314SPH532_0160 ME	3500	7000	≤ 24	1.02	19	6	87	3	14	44.6	5.2	9.9	14	221
16.000	ZTR314SPH532_0160 MEL	3500	7000	≤ 32	1.02	19	6	87	3	14	44.6	5.2	9.9	14	221

i	Type	n_{1maxDB}	n_{1maxZB}	d_{MW}	$v_{f2maxZB}$	Δs	Δs_{red}	C_{lin}	m_n	z	d_0	F_{f2N}	F_{f2acc}	F_{f2NOT}	M_{2acc}
		[rpm]	[rpm]	[mm]	[m/s]	[μ m]	[μ m]	[N/ μ m]	[mm]						
ZTR3PH5 ($F_{f2acc,max} = 9,9$ kN)															
20.00	ZTR314SPH532_0200 ME	3500	7000	≤24	0.82	19	6	87	3	14	44.6	5.6	9.9	14	221
20.00	ZTR314SPH532_0200 MEL	3500	7000	≤32	0.82	19	6	87	3	14	44.6	5.6	9.9	14	221
25.00	ZTR314SPH532_0250 ME	3700	7500	≤24	0.70	19	6	87	3	14	44.6	6.0	9.9	14	221
25.00	ZTR314SPH532_0250 MEL	3700	7500	≤32	0.70	19	6	87	3	14	44.6	6.0	9.9	14	221
28.00	ZTR314SPH532_0280 ME	4000	8000	≤24	0.67	19	6	86	3	14	44.6	6.0	9.9	14	221
28.00	ZTR314SPH532_0280 MEL	4000	8000	≤32	0.67	19	6	86	3	14	44.6	6.0	9.9	14	221
35.00	ZTR314SPH532_0350 ME	4000	8000	≤24	0.53	19	6	87	3	14	44.6	6.0	9.9	14	221
35.00	ZTR314SPH532_0350 MEL	4000	8000	≤32	0.53	19	6	87	3	14	44.6	6.0	9.9	14	221
40.00	ZTR314SPH532_0400 ME	4000	8000	≤24	0.47	19	6	85	3	14	44.6	6.0	9.9	14	221
40.00	ZTR314SPH532_0400 MEL	4000	8000	≤32	0.47	19	6	85	3	14	44.6	6.0	9.9	14	221
50.00	ZTR314SPH532_0500 ME	4000	8000	≤24	0.37	19	6	86	3	14	44.6	6.0	9.9	14	221
50.00	ZTR314SPH532_0500 MEL	4000	8000	≤32	0.37	19	6	86	3	14	44.6	6.0	9.9	14	221
70.00	ZTR314SPH532_0700 ME	4000	8000	≤24	0.27	19	6	84	3	14	44.6	6.0	9.9	14	221
70.00	ZTR314SPH532_0700 MEL	4000	8000	≤32	0.27	19	6	84	3	14	44.6	6.0	9.9	14	221
100.0	ZTR314SPH532_1000 ME	4000	8000	≤24	0.19	19	6	80	3	14	44.6	6.0	9.9	14	221
100.0	ZTR314SPH532_1000 MEL	4000	8000	≤32	0.19	19	6	80	3	14	44.6	6.0	9.9	14	221
ZTR2PH7 ($F_{f2acc,max} = 15$ kN)															
4.000	ZTR223SPH731_0040 ME	1900	4000	≤38	2.56	21	7	119	2	23	48.8	8.7	15	29	356
4.000	ZTR223SPH731_0040 MEL	1900	4000	≤48	2.56	21	7	120	2	23	48.8	8.7	15	29	356
5.000	ZTR223SPH731_0050 ME	2200	5000	≤38	2.56	21	7	118	2	23	48.8	9.4	15	29	356
5.000	ZTR223SPH731_0050 MEL	2200	5000	≤48	2.56	21	7	119	2	23	48.8	9.4	15	29	356
7.000	ZTR223SPH731_0070 ME	2500	5000	≤38	1.83	21	7	116	2	23	48.8	10	15	29	356
7.000	ZTR223SPH731_0070 MEL	2500	5000	≤48	1.83	21	7	116	2	23	48.8	10	15	29	356
10.00	ZTR223SPH731_0100 ME	2500	5000	≤38	1.28	21	7	112	2	23	48.8	12	15	29	356
10.00	ZTR223SPH731_0100 MEL	2500	5000	≤48	1.28	21	7	112	2	23	48.8	12	15	29	356
16.00	ZTR223SPH732_0160 ME	3000	6000	≤32	0.96	21	7	119	2	23	48.8	14	15	29	356
16.00	ZTR223SPH732_0160 MEL	3000	6000	≤38	0.96	21	7	119	2	23	48.8	14	15	29	356
20.00	ZTR223SPH732_0200 ME	3000	6000	≤32	0.77	21	7	118	2	23	48.8	15	15	29	356
20.00	ZTR223SPH732_0200 MEL	3000	6000	≤38	0.77	21	7	118	2	23	48.8	15	15	29	356
25.00	ZTR223SPH732_0250 ME	3500	7000	≤32	0.72	21	7	118	2	23	48.8	15	15	29	356
25.00	ZTR223SPH732_0250 MEL	3500	7000	≤38	0.72	21	7	118	2	23	48.8	15	15	29	356
28.00	ZTR223SPH732_0280 ME	3700	7000	≤32	0.64	21	7	118	2	23	48.8	15	15	29	356
28.00	ZTR223SPH732_0280 MEL	3700	7000	≤38	0.64	21	7	118	2	23	48.8	15	15	29	356
35.00	ZTR223SPH732_0350 ME	3700	7000	≤32	0.51	21	7	118	2	23	48.8	15	15	29	356
35.00	ZTR223SPH732_0350 MEL	3700	7000	≤38	0.51	21	7	118	2	23	48.8	15	15	29	356
40.00	ZTR223SPH732_0400 ME	3700	7000	≤32	0.45	21	7	118	2	23	48.8	15	15	29	356
40.00	ZTR223SPH732_0400 MEL	3700	7000	≤38	0.45	21	7	118	2	23	48.8	15	15	29	356
50.00	ZTR223SPH732_0500 ME	3700	7000	≤32	0.36	21	7	117	2	23	48.8	15	15	29	356
50.00	ZTR223SPH732_0500 MEL	3700	7000	≤38	0.36	21	7	117	2	23	48.8	15	15	29	356
70.00	ZTR223SPH732_0700 ME	3700	7000	≤32	0.26	21	7	115	2	23	48.8	15	15	29	356
70.00	ZTR223SPH732_0700 MEL	3700	7000	≤38	0.26	21	7	115	2	23	48.8	15	15	29	356
100.0	ZTR223SPH732_1000 ME	3700	7000	≤32	0.18	21	7	111	2	23	48.8	15	15	29	356
100.0	ZTR223SPH732_1000 MEL	3700	7000	≤38	0.18	21	7	111	2	23	48.8	15	15	29	356
ZTR3PH7 ($F_{f2acc,max} = 19$ kN)															
4.000	ZTR316SPH731_0040 ME	1900	4000	≤38	2.67	22	7	118	3	16	50.9	8.5	17	30	446
4.000	ZTR316SPH731_0040 MEL	1900	4000	≤48	2.67	22	7	119	3	16	50.9	8.5	17	30	446
4.000	ZTR319SPH731_0040 ME	1900	4000	≤38	3.17	26	9	115	3	19	60.5	8.5	19	26	565
4.000	ZTR319SPH731_0040 MEL	1900	4000	≤48	3.17	26	9	116	3	19	60.5	8.5	19	26	565
5.000	ZTR316SPH731_0050 ME	2200	5000	≤38	2.67	22	7	117	3	16	50.9	9.2	17	30	446
5.000	ZTR316SPH731_0050 MEL	2200	5000	≤48	2.67	22	7	118	3	16	50.9	9.2	17	30	446
5.000	ZTR319SPH731_0050 ME	2200	5000	≤38	3.17	26	9	113	3	19	60.5	9.1	19	26	565
5.000	ZTR319SPH731_0050 MEL	2200	5000	≤48	3.17	26	9	114	3	19	60.5	9.1	19	26	565
7.000	ZTR316SPH731_0070 ME	2500	5000	≤38	1.91	22	7	115	3	16	50.9	10	17	30	446
7.000	ZTR316SPH731_0070 MEL	2500	5000	≤48	1.91	22	7	115	3	16	50.9	10	17	30	446
7.000	ZTR319SPH731_0070 ME	2500	5000	≤38	2.26	26	9	110	3	19	60.5	10	19	26	565
7.000	ZTR319SPH731_0070 MEL	2500	5000	≤48	2.26	26	9	110	3	19	60.5	10	19	26	565
10.00	ZTR316SPH731_0100 ME	2500	5000	≤38	1.33	22	7	110	3	16	50.9	12	17	30	446
10.00	ZTR316SPH731_0100 MEL	2500	5000	≤48	1.33	22	7	110	3	16	50.9	12	17	30	446
10.00	ZTR319SPH731_0100 ME	2500	5000	≤38	1.58	26	9	104	3	19	60.5	12	19	26	565
10.00	ZTR319SPH731_0100 MEL	2500	5000	≤48	1.58	26	9	104	3	19	60.5	12	19	26	565
16.00	ZTR316SPH732_0160 ME	3000	6000	≤32	1.00	22	7	118	3	16	50.9	14	17	30	446
16.00	ZTR316SPH732_0160 MEL	3000	6000	≤38	1.00	22	7	118	3	16	50.9	14	17	30	446
16.00	ZTR319SPH732_0160 ME	3000	6000	≤32	1.19	26	9	114	3	19	60.5	13	19	26	565
16.00	ZTR319SPH732_0160 MEL	3000	6000	≤38	1.19	26	9	114	3	19	60.5	13	19	26	565
20.00	ZTR316SPH732_0200 ME	3000	6000	≤32	0.80	22	7	117	3	16	50.9	15	17	30	446
20.00	ZTR316SPH732_0200 MEL	3000	6000	≤38	0.80	22	7	117	3	16	50.9	15	17	30	446

5.2 Selection tables 5 ZTRPH rack and pinion drives

i	Type	n_{1maxDB}	n_{1maxZB}	d_{MW}	$v_{f2maxZB}$	Δs	Δs_{red}	C_{lin}	m_n	z	d_0	F_{f2N}	F_{f2acc}	F_{f2NOT}	M_{2acc}
		[rpm]	[rpm]	[mm]	[m/s]	[μm]	[μm]	[N/ μm]	[mm]		[mm]	[kN]	[kN]	[kN]	[Nm]
ZTR3PH7 ($F_{f2acc,max} = 19$ kN)															
20.00	ZTR319SPH732_0200 ME	3000	6000	≤32	0.95	26	9	113	3	19	60.5	15	19	26	565
20.00	ZTR319SPH732_0200 MEL	3000	6000	≤38	0.95	26	9	113	3	19	60.5	15	19	26	565
25.00	ZTR316SPH732_0250 ME	3500	7000	≤32	0.75	22	7	117	3	16	50.9	16	17	30	446
25.00	ZTR316SPH732_0250 MEL	3500	7000	≤38	0.75	22	7	117	3	16	50.9	16	17	30	446
25.00	ZTR319SPH732_0250 ME	3500	7000	≤32	0.89	26	9	113	3	19	60.5	16	19	26	565
25.00	ZTR319SPH732_0250 MEL	3500	7000	≤38	0.89	26	9	113	3	19	60.5	16	19	26	565
28.00	ZTR316SPH732_0280 ME	3700	7000	≤32	0.67	22	7	117	3	16	50.9	16	17	30	446
28.00	ZTR316SPH732_0280 MEL	3700	7000	≤38	0.67	22	7	117	3	16	50.9	16	17	30	446
28.00	ZTR319SPH732_0280 ME	3700	7000	≤32	0.79	26	9	114	3	19	60.5	16	19	26	565
28.00	ZTR319SPH732_0280 MEL	3700	7000	≤38	0.79	26	9	114	3	19	60.5	16	19	26	565
35.00	ZTR316SPH732_0350 ME	3700	7000	≤32	0.53	22	7	117	3	16	50.9	16	17	30	446
35.00	ZTR316SPH732_0350 MEL	3700	7000	≤38	0.53	22	7	117	3	16	50.9	16	17	30	446
35.00	ZTR319SPH732_0350 ME	3700	7000	≤32	0.63	26	9	113	3	19	60.5	16	19	26	565
35.00	ZTR319SPH732_0350 MEL	3700	7000	≤38	0.63	26	9	113	3	19	60.5	16	19	26	565
40.00	ZTR316SPH732_0400 ME	3700	7000	≤32	0.47	22	7	116	3	16	50.9	16	17	30	446
40.00	ZTR316SPH732_0400 MEL	3700	7000	≤38	0.47	22	7	116	3	16	50.9	16	17	30	446
40.00	ZTR319SPH732_0400 ME	3700	7000	≤32	0.55	26	9	113	3	19	60.5	16	19	26	565
40.00	ZTR319SPH732_0400 MEL	3700	7000	≤38	0.55	26	9	113	3	19	60.5	16	19	26	565
50.00	ZTR316SPH732_0500 ME	3700	7000	≤32	0.37	22	7	116	3	16	50.9	16	17	30	446
50.00	ZTR316SPH732_0500 MEL	3700	7000	≤38	0.37	22	7	116	3	16	50.9	16	17	30	446
50.00	ZTR319SPH732_0500 ME	3700	7000	≤32	0.44	26	9	112	3	19	60.5	16	19	26	565
50.00	ZTR319SPH732_0500 MEL	3700	7000	≤38	0.44	26	9	112	3	19	60.5	16	19	26	565
70.00	ZTR316SPH732_0700 ME	3700	7000	≤32	0.27	22	7	114	3	16	50.9	16	17	30	446
70.00	ZTR316SPH732_0700 MEL	3700	7000	≤38	0.27	22	7	114	3	16	50.9	16	17	30	446
70.00	ZTR319SPH732_0700 ME	3700	7000	≤32	0.32	26	9	109	3	19	60.5	16	19	26	565
70.00	ZTR319SPH732_0700 MEL	3700	7000	≤38	0.32	26	9	109	3	19	60.5	16	19	26	565
100.0	ZTR316SPH732_1000 ME	3700	7000	≤32	0.19	22	7	110	3	16	50.9	16	17	30	446
100.0	ZTR316SPH732_1000 MEL	3700	7000	≤38	0.19	22	7	110	3	16	50.9	16	17	30	446
100.0	ZTR319SPH732_1000 ME	3700	7000	≤32	0.22	26	9	104	3	19	60.5	14	18	26	550
100.0	ZTR319SPH732_1000 MEL	3700	7000	≤38	0.22	26	9	104	3	19	60.5	14	18	26	550
ZTR4PH7 ($F_{f2acc,max} = 18$ kN)															
4.000	ZTR412SPH731_0040 ME	1900	4000	≤38	2.67	22	7	114	4	12	50.9	8.2	18	28	459
4.000	ZTR412SPH731_0040 MEL	1900	4000	≤48	2.67	22	7	115	4	12	50.9	8.2	18	28	459
5.000	ZTR412SPH731_0050 ME	2200	5000	≤38	2.67	22	7	113	4	12	50.9	8.8	18	28	459
5.000	ZTR412SPH731_0050 MEL	2200	5000	≤48	2.67	22	7	114	4	12	50.9	8.8	18	28	459
7.000	ZTR412SPH731_0070 ME	2500	5000	≤38	1.91	22	7	111	4	12	50.9	9.9	18	28	459
7.000	ZTR412SPH731_0070 MEL	2500	5000	≤48	1.91	22	7	111	4	12	50.9	9.9	18	28	459
10.00	ZTR412SPH731_0100 ME	2500	5000	≤38	1.33	22	7	107	4	12	50.9	11	18	28	459
10.00	ZTR412SPH731_0100 MEL	2500	5000	≤48	1.33	22	7	107	4	12	50.9	11	18	28	459
16.00	ZTR412SPH732_0160 ME	3000	6000	≤32	1.00	22	7	114	4	12	50.9	13	18	28	459
16.00	ZTR412SPH732_0160 MEL	3000	6000	≤38	1.00	22	7	114	4	12	50.9	13	18	28	459
20.00	ZTR412SPH732_0200 ME	3000	6000	≤32	0.80	22	7	113	4	12	50.9	14	18	28	459
20.00	ZTR412SPH732_0200 MEL	3000	6000	≤38	0.80	22	7	113	4	12	50.9	14	18	28	459
25.00	ZTR412SPH732_0250 ME	3500	7000	≤32	0.75	22	7	113	4	12	50.9	15	18	28	459
25.00	ZTR412SPH732_0250 MEL	3500	7000	≤38	0.75	22	7	113	4	12	50.9	15	18	28	459
28.00	ZTR412SPH732_0280 ME	3700	7000	≤32	0.67	22	7	114	4	12	50.9	15	18	28	459
28.00	ZTR412SPH732_0280 MEL	3700	7000	≤38	0.67	22	7	114	4	12	50.9	15	18	28	459
35.00	ZTR412SPH732_0350 ME	3700	7000	≤32	0.53	22	7	113	4	12	50.9	15	18	28	459
35.00	ZTR412SPH732_0350 MEL	3700	7000	≤38	0.53	22	7	113	4	12	50.9	15	18	28	459
40.00	ZTR412SPH732_0400 ME	3700	7000	≤32	0.47	22	7	113	4	12	50.9	15	18	28	459
40.00	ZTR412SPH732_0400 MEL	3700	7000	≤38	0.47	22	7	113	4	12	50.9	15	18	28	459
50.00	ZTR412SPH732_0500 ME	3700	7000	≤32	0.37	22	7	112	4	12	50.9	15	18	28	459
50.00	ZTR412SPH732_0500 MEL	3700	7000	≤38	0.37	22	7	112	4	12	50.9	15	18	28	459
70.00	ZTR412SPH732_0700 ME	3700	7000	≤32	0.27	22	7	110	4	12	50.9	15	18	28	459
70.00	ZTR412SPH732_0700 MEL	3700	7000	≤38	0.27	22	7	110	4	12	50.9	15	18	28	459
100.0	ZTR412SPH732_1000 ME	3700	7000	≤32	0.19	22	7	107	4	12	50.9	15	18	28	459
100.0	ZTR412SPH732_1000 MEL	3700	7000	≤38	0.19	22	7	107	4	12	50.9	15	18	28	459
ZTR3PH8 ($F_{f2acc,max} = 25$ kN)															
4.000	ZTR332SPH831_0040 ME	1400	3500	≤48	4.67	44	15	184	3	32	101.9	17	25	44	1294
4.000	ZTR332SPH831_0040 MEL	1400	3500	≤60	4.67	44	15	188	3	32	101.9	17	25	44	1294
5.000	ZTR332SPH831_0050 ME	1600	4000	≤48	4.27	44	15	186	3	32	101.9	21	25	44	1294
5.000	ZTR332SPH831_0050 MEL	1600	4000	≤60	4.27	44	15	188	3	32	101.9	21	25	44	1294
7.000	ZTR332SPH831_0070 ME	2000	4000	≤48	3.05	44	15	176	3	32	101.9	20	25	44	1294
7.000	ZTR332SPH831_0070 MEL	2000	4000	≤60	3.05	44	15	177	3	32	101.9	20	25	44	1294
10.00	ZTR332SPH831_0100 ME	2200	4000	≤48	2.13	44	15	161	3	32	101.9	17	25	44	1294
10.00	ZTR332SPH831_0100 MEL	2200	4000	≤60	2.13	44	15	162	3	32	101.9	17	25	44	1294

i	Type	n_{1maxDB}	n_{1maxZB}	d_{MW}	$v_{f2maxZB}$	Δs	Δs_{red}	C_{lin}	m_n	z	d_0	F_{f2N}	F_{f2acc}	F_{f2NOT}	M_{2acc}
		[rpm]	[rpm]	[mm]	[m/s]	[μ m]	[μ m]	[N/ μ m]	[mm]		[mm]	[kN]	[kN]	[kN]	[Nm]
ZTR3PH8 ($F_{f2acc,max} = 25$ kN)															
16.00	ZTR332SPH832_0160 ME	2500	4500	≤38	1.50	44	15	182	3	32	101.9	22	25	44	1294
16.00	ZTR332SPH832_0160 MEL	2500	4500	≤48	1.50	44	15	182	3	32	101.9	22	25	44	1294
20.00	ZTR332SPH832_0200 ME	2500	4500	≤38	1.20	44	15	184	3	32	101.9	25	25	44	1294
20.00	ZTR332SPH832_0200 MEL	2500	4500	≤48	1.20	44	15	185	3	32	101.9	25	25	44	1294
25.00	ZTR332SPH832_0250 ME	2700	5500	≤38	1.17	44	15	184	3	32	101.9	25	25	44	1294
25.00	ZTR332SPH832_0250 MEL	2700	5500	≤48	1.17	44	15	184	3	32	101.9	25	25	44	1294
28.00	ZTR332SPH832_0280 ME	3000	6000	≤38	1.14	44	15	180	3	32	101.9	22	25	44	1294
28.00	ZTR332SPH832_0280 MEL	3000	6000	≤48	1.14	44	15	180	3	32	101.9	22	25	44	1294
35.00	ZTR332SPH832_0350 ME	3000	6000	≤38	0.91	44	15	183	3	32	101.9	25	25	44	1294
35.00	ZTR332SPH832_0350 MEL	3000	6000	≤48	0.91	44	15	184	3	32	101.9	25	25	44	1294
40.00	ZTR332SPH832_0400 ME	3000	6000	≤38	0.80	44	15	177	3	32	101.9	22	25	44	1294
40.00	ZTR332SPH832_0400 MEL	3000	6000	≤48	0.80	44	15	177	3	32	101.9	22	25	44	1294
50.00	ZTR332SPH832_0500 ME	3000	6000	≤38	0.64	44	15	182	3	32	101.9	25	25	44	1294
50.00	ZTR332SPH832_0500 MEL	3000	6000	≤48	0.64	44	15	182	3	32	101.9	25	25	44	1294
70.00	ZTR332SPH832_0700 ME	3000	6000	≤38	0.46	44	15	174	3	32	101.9	25	25	44	1294
70.00	ZTR332SPH832_0700 MEL	3000	6000	≤48	0.46	44	15	174	3	32	101.9	25	25	44	1294
100.0	ZTR332SPH832_1000 ME	3000	6000	≤38	0.32	44	15	161	3	32	101.9	21	25	44	1294
100.0	ZTR332SPH832_1000 MEL	3000	6000	≤48	0.32	44	15	161	3	32	101.9	21	25	44	1294
ZTR4PH8 ($F_{f2acc,max} = 36$ kN)															
4.000	ZTR417SPH831_0040 ME	1400	3500	≤48	3.31	31	10	217	4	17	72.2	20	35	55	1263
4.000	ZTR417SPH831_0040 MEL	1400	3500	≤60	3.31	31	10	220	4	17	72.2	20	35	55	1263
4.000	ZTR420SPH831_0040 ME	1400	3500	≤48	3.89	37	12	207	4	20	84.9	20	36	50	1511
4.000	ZTR420SPH831_0040 MEL	1400	3500	≤60	3.89	37	12	210	4	20	84.9	20	36	50	1511
5.000	ZTR417SPH831_0050 ME	1600	4000	≤48	3.02	31	10	218	4	17	72.2	21	35	55	1263
5.000	ZTR417SPH831_0050 MEL	1600	4000	≤60	3.02	31	10	220	4	17	72.2	21	35	55	1263
5.000	ZTR420SPH831_0050 ME	1600	4000	≤48	3.56	37	12	209	4	20	84.9	21	36	50	1511
5.000	ZTR420SPH831_0050 MEL	1600	4000	≤60	3.56	37	12	211	4	20	84.9	21	36	50	1511
7.000	ZTR417SPH831_0070 ME	2000	4000	≤48	2.16	31	10	211	4	17	72.2	24	35	55	1263
7.000	ZTR417SPH831_0070 MEL	2000	4000	≤60	2.16	31	10	212	4	17	72.2	24	35	55	1263
7.000	ZTR420SPH831_0070 ME	2000	4000	≤48	2.54	37	12	200	4	20	84.9	24	36	50	1511
7.000	ZTR420SPH831_0070 MEL	2000	4000	≤60	2.54	37	12	201	4	20	84.9	24	36	50	1511
10.00	ZTR417SPH831_0100 ME	2200	4000	≤48	1.51	31	10	200	4	17	72.2	24	35	55	1263
10.00	ZTR417SPH831_0100 MEL	2200	4000	≤60	1.51	31	10	201	4	17	72.2	24	35	55	1263
10.00	ZTR420SPH831_0100 ME	2200	4000	≤48	1.78	37	12	187	4	20	84.9	20	33	50	1392
10.00	ZTR420SPH831_0100 MEL	2200	4000	≤60	1.78	37	12	187	4	20	84.9	20	33	50	1392
16.00	ZTR417SPH832_0160 ME	2500	4500	≤38	1.06	31	10	215	4	17	72.2	30	35	55	1263
16.00	ZTR417SPH832_0160 MEL	2500	4500	≤48	1.06	31	10	216	4	17	72.2	30	35	55	1263
16.00	ZTR420SPH832_0160 ME	2500	4500	≤38	1.25	37	12	205	4	20	84.9	26	36	50	1511
16.00	ZTR420SPH832_0160 MEL	2500	4500	≤48	1.25	37	12	206	4	20	84.9	26	36	50	1511
20.00	ZTR417SPH832_0200 ME	2500	4500	≤38	0.85	31	10	217	4	17	72.2	34	35	55	1263
20.00	ZTR417SPH832_0200 MEL	2500	4500	≤48	0.85	31	10	218	4	17	72.2	34	35	55	1263
20.00	ZTR420SPH832_0200 ME	2500	4500	≤38	1.00	37	12	208	4	20	84.9	29	36	50	1511
20.00	ZTR420SPH832_0200 MEL	2500	4500	≤48	1.00	37	12	208	4	20	84.9	29	36	50	1511
25.00	ZTR417SPH832_0250 ME	2700	5500	≤38	0.83	31	10	217	4	17	72.2	35	35	55	1263
25.00	ZTR417SPH832_0250 MEL	2700	5500	≤48	0.83	31	10	217	4	17	72.2	35	35	55	1263
25.00	ZTR420SPH832_0250 ME	2700	5500	≤38	0.98	37	12	208	4	20	84.9	31	36	50	1511
25.00	ZTR420SPH832_0250 MEL	2700	5500	≤48	0.98	37	12	208	4	20	84.9	31	36	50	1511
28.00	ZTR417SPH832_0280 ME	3000	6000	≤38	0.81	31	10	214	4	17	72.2	30	35	55	1263
28.00	ZTR417SPH832_0280 MEL	3000	6000	≤48	0.81	31	10	215	4	17	72.2	30	35	55	1263
28.00	ZTR420SPH832_0280 ME	3000	6000	≤38	0.95	37	12	204	4	20	84.9	26	36	50	1511
28.00	ZTR420SPH832_0280 MEL	3000	6000	≤48	0.95	37	12	204	4	20	84.9	26	36	50	1511
35.00	ZTR417SPH832_0350 ME	3000	6000	≤38	0.65	31	10	217	4	17	72.2	35	35	55	1263
35.00	ZTR417SPH832_0350 MEL	3000	6000	≤48	0.65	31	10	217	4	17	72.2	35	35	55	1263
35.00	ZTR420SPH832_0350 ME	3000	6000	≤38	0.76	37	12	207	4	20	84.9	34	36	50	1511
35.00	ZTR420SPH832_0350 MEL	3000	6000	≤48	0.76	37	12	207	4	20	84.9	34	36	50	1511
40.00	ZTR417SPH832_0400 ME	3000	6000	≤38	0.57	31	10	212	4	17	72.2	30	35	55	1263
40.00	ZTR417SPH832_0400 MEL	3000	6000	≤48	0.57	31	10	212	4	17	72.2	30	35	55	1263
40.00	ZTR420SPH832_0400 ME	3000	6000	≤38	0.67	37	12	201	4	20	84.9	26	36	50	1511
40.00	ZTR420SPH832_0400 MEL	3000	6000	≤48	0.67	37	12	202	4	20	84.9	26	36	50	1511
50.00	ZTR417SPH832_0500 ME	3000	6000	≤38	0.45	31	10	215	4	17	72.2	35	35	55	1263
50.00	ZTR417SPH832_0500 MEL	3000	6000	≤48	0.45	31	10	215	4	17	72.2	35	35	55	1263
50.00	ZTR420SPH832_0500 ME	3000	6000	≤38	0.53	37	12	205	4	20	84.9	36	36	50	1511
50.00	ZTR420SPH832_0500 MEL	3000	6000	≤48	0.53	37	12	205	4	20	84.9	36	36	50	1511
70.00	ZTR417SPH832_0700 ME	3000	6000	≤38	0.32	31	10	210	4	17	72.2	35	35	55	1263
70.00	ZTR417SPH832_0700 MEL	3000	6000	≤48	0.32	31	10	210	4	17	72.2	35	35	55	1263
70.00	ZTR420SPH832_0700 ME	3000	6000	≤38	0.38	37	12	199	4	20	84.9	33	36	50	1511

5.2 Selection tables 5 ZTRPH rack and pinion drives

i	Type	n_{1maxDB}	n_{1maxZB}	d_{MW}	$v_{f2maxZB}$	Δs	Δs_{red}	C_{lin}	m_n	z	d_0	F_{f2N}	F_{f2acc}	F_{f2NOT}	M_{2acc}
		[rpm]	[rpm]	[mm]	[m/s]	[μ m]	[μ m]	[N/ μ m]	[mm]		[mm]	[kN]	[kN]	[kN]	[Nm]
ZTR4PH8 ($F_{f2acc,max} = 36$ kN)															
70.00	ZTR420SPH832_0700 MEL	3000	6000	≤48	0.38	37	12	199	4	20	84.9	33	36	50	1511
100.0	ZTR417SPH832_1000 ME	3000	6000	≤38	0.23	31	10	200	4	17	72.2	29	35	55	1263
100.0	ZTR417SPH832_1000 MEL	3000	6000	≤48	0.23	31	10	200	4	17	72.2	29	35	55	1263
100.0	ZTR420SPH832_1000 ME	3000	6000	≤38	0.27	37	12	186	4	20	84.9	25	33	50	1380
100.0	ZTR420SPH832_1000 MEL	3000	6000	≤48	0.27	37	12	186	4	20	84.9	25	33	50	1380
ZTR5PH8 ($F_{f2acc,max} = 34$ kN)															
4.000	ZTR518SPH831_0040 ME	1400	3500	≤48	4.38	42	14	202	5	18	95.5	18	34	44	1621
4.000	ZTR518SPH831_0040 MEL	1400	3500	≤60	4.38	42	14	206	5	18	95.5	18	34	44	1621
5.000	ZTR518SPH831_0050 ME	1600	4000	≤48	4.00	42	14	204	5	18	95.5	20	34	44	1621
5.000	ZTR518SPH831_0050 MEL	1600	4000	≤60	4.00	42	14	207	5	18	95.5	20	34	44	1621
7.000	ZTR518SPH831_0070 ME	2000	4000	≤48	2.86	42	14	194	5	18	95.5	21	34	44	1621
7.000	ZTR518SPH831_0070 MEL	2000	4000	≤60	2.86	42	14	195	5	18	95.5	21	34	44	1621
10.00	ZTR518SPH831_0100 ME	2200	4000	≤48	2.00	42	14	178	5	18	95.5	18	29	44	1392
10.00	ZTR518SPH831_0100 MEL	2200	4000	≤60	2.00	42	14	179	5	18	95.5	18	29	44	1392
16.00	ZTR518SPH832_0160 ME	2500	4500	≤38	1.41	42	14	200	5	18	95.5	23	34	44	1621
16.00	ZTR518SPH832_0160 MEL	2500	4500	≤48	1.41	42	14	200	5	18	95.5	23	34	44	1621
20.00	ZTR518SPH832_0200 ME	2500	4500	≤38	1.13	42	14	203	5	18	95.5	26	34	44	1621
20.00	ZTR518SPH832_0200 MEL	2500	4500	≤48	1.13	42	14	203	5	18	95.5	26	34	44	1621
25.00	ZTR518SPH832_0250 ME	2700	5500	≤38	1.10	42	14	203	5	18	95.5	27	34	44	1621
25.00	ZTR518SPH832_0250 MEL	2700	5500	≤48	1.10	42	14	203	5	18	95.5	27	34	44	1621
28.00	ZTR518SPH832_0280 ME	3000	6000	≤38	1.07	42	14	198	5	18	95.5	23	34	44	1621
28.00	ZTR518SPH832_0280 MEL	3000	6000	≤48	1.07	42	14	198	5	18	95.5	23	34	44	1621
35.00	ZTR518SPH832_0350 ME	3000	6000	≤38	0.86	42	14	202	5	18	95.5	30	34	44	1621
35.00	ZTR518SPH832_0350 MEL	3000	6000	≤48	0.86	42	14	202	5	18	95.5	30	34	44	1621
40.00	ZTR518SPH832_0400 ME	3000	6000	≤38	0.75	42	14	195	5	18	95.5	23	34	44	1621
40.00	ZTR518SPH832_0400 MEL	3000	6000	≤48	0.75	42	14	195	5	18	95.5	23	34	44	1621
50.00	ZTR518SPH832_0500 ME	3000	6000	≤38	0.60	42	14	200	5	18	95.5	33	34	44	1621
50.00	ZTR518SPH832_0500 MEL	3000	6000	≤48	0.60	42	14	200	5	18	95.5	33	34	44	1621
70.00	ZTR518SPH832_0700 ME	3000	6000	≤38	0.43	42	14	192	5	18	95.5	30	34	44	1621
70.00	ZTR518SPH832_0700 MEL	3000	6000	≤48	0.43	42	14	192	5	18	95.5	30	34	44	1621
100.0	ZTR518SPH832_1000 ME	3000	6000	≤38	0.30	42	14	177	5	18	95.5	22	29	44	1380
100.0	ZTR518SPH832_1000 MEL	3000	6000	≤48	0.30	42	14	177	5	18	95.5	22	29	44	1380
ZTR6PH8 ($F_{f2acc,max} = 33$ kN)															
4.000	ZTR615SPH831_0040 ME	1400	3500	≤48	4.38	42	14	203	6	15	95.5	18	33	44	1577
4.000	ZTR615SPH831_0040 MEL	1400	3500	≤60	4.38	42	14	207	6	15	95.5	18	33	44	1577
5.000	ZTR615SPH831_0050 ME	1600	4000	≤48	4.00	42	14	205	6	15	95.5	20	33	44	1577
5.000	ZTR615SPH831_0050 MEL	1600	4000	≤60	4.00	42	14	208	6	15	95.5	20	33	44	1577
7.000	ZTR615SPH831_0070 ME	2000	4000	≤48	2.86	42	14	195	6	15	95.5	21	33	44	1577
7.000	ZTR615SPH831_0070 MEL	2000	4000	≤60	2.86	42	14	196	6	15	95.5	21	33	44	1577
10.00	ZTR615SPH831_0100 ME	2200	4000	≤48	2.00	42	14	179	6	15	95.5	18	29	44	1392
10.00	ZTR615SPH831_0100 MEL	2200	4000	≤60	2.00	42	14	179	6	15	95.5	18	29	44	1392
16.00	ZTR615SPH832_0160 ME	2500	4500	≤38	1.41	42	14	201	6	15	95.5	23	33	44	1577
16.00	ZTR615SPH832_0160 MEL	2500	4500	≤48	1.41	42	14	201	6	15	95.5	23	33	44	1577
20.00	ZTR615SPH832_0200 ME	2500	4500	≤38	1.13	42	14	204	6	15	95.5	26	33	44	1577
20.00	ZTR615SPH832_0200 MEL	2500	4500	≤48	1.13	42	14	204	6	15	95.5	26	33	44	1577
25.00	ZTR615SPH832_0250 ME	2700	5500	≤38	1.10	42	14	203	6	15	95.5	27	33	44	1577
25.00	ZTR615SPH832_0250 MEL	2700	5500	≤48	1.10	42	14	204	6	15	95.5	27	33	44	1577
28.00	ZTR615SPH832_0280 ME	3000	6000	≤38	1.07	42	14	199	6	15	95.5	23	33	44	1577
28.00	ZTR615SPH832_0280 MEL	3000	6000	≤48	1.07	42	14	199	6	15	95.5	23	33	44	1577
35.00	ZTR615SPH832_0350 ME	3000	6000	≤38	0.86	42	14	203	6	15	95.5	30	33	44	1577
35.00	ZTR615SPH832_0350 MEL	3000	6000	≤48	0.86	42	14	203	6	15	95.5	30	33	44	1577
40.00	ZTR615SPH832_0400 ME	3000	6000	≤38	0.75	42	14	196	6	15	95.5	23	33	44	1577
40.00	ZTR615SPH832_0400 MEL	3000	6000	≤48	0.75	42	14	196	6	15	95.5	23	33	44	1577
50.00	ZTR615SPH832_0500 ME	3000	6000	≤38	0.60	42	14	201	6	15	95.5	33	33	44	1577
50.00	ZTR615SPH832_0500 MEL	3000	6000	≤48	0.60	42	14	201	6	15	95.5	33	33	44	1577
70.00	ZTR615SPH832_0700 ME	3000	6000	≤38	0.43	42	14	193	6	15	95.5	30	33	44	1577
70.00	ZTR615SPH832_0700 MEL	3000	6000	≤48	0.43	42	14	193	6	15	95.5	30	33	44	1577
100.0	ZTR615SPH832_1000 ME	3000	6000	≤38	0.30	42	14	178	6	15	95.5	22	29	44	1380
100.0	ZTR615SPH832_1000 MEL	3000	6000	≤48	0.30	42	14	178	6	15	95.5	22	29	44	1380
ZTR5PH9 ($F_{f2acc,max} = 67$ kN)															
12.00	ZTR519SPH942_0120 ME	1800	3000	≤48	1.32	44	15	306	5	19	100.8	42	67	133	3360
12.00	ZTR519SPH942_0120 MEL	1800	3000	≤60	1.32	44	15	307	5	19	100.8	42	67	133	3360
16.00	ZTR519SPH942_0160 ME	2000	3500	≤48	1.15	44	15	305	5	19	100.8	47	67	133	3360
16.00	ZTR519SPH942_0160 MEL	2000	3500	≤60	1.15	44	15	306	5	19	100.8	47	67	133	3360
18.00	ZTR519SPH942_0180 ME	1800	3000	≤48	0.88	44	15	302	5	19	100.8	49	67	133	3360
18.00	ZTR519SPH942_0180 MEL	1800	3000	≤60	0.88	44	15	302	5	19	100.8	49	67	133	3360

i	Type	n_{1maxDB}	n_{1maxZB}	d_{MW}	$v_{f2maxZB}$	Δs	Δs_{red}	C_{lin}	m_n	z	d_0	F_{f2N}	F_{f2acc}	F_{f2NOT}	M_{2acc}
		[rpm]	[rpm]	[mm]	[m/s]	[μ m]	[μ m]	[N/ μ m]	[mm]		[mm]	[kN]	[kN]	[kN]	[Nm]
ZTR5PH9 ($F_{f2acc,max} = 67$ kN)															
20.00	ZTR519SPH942_0200 ME	2500	4000	≤48	1.06	44	15	305	5	19	100.8	50	67	133	3360
20.00	ZTR519SPH942_0200 MEL	2500	4000	≤60	1.06	44	15	305	5	19	100.8	50	67	133	3360
24.00	ZTR519SPH942_0240 ME	2000	3500	≤48	0.77	44	15	302	5	19	100.8	53	67	133	3360
24.00	ZTR519SPH942_0240 MEL	2000	3500	≤60	0.77	44	15	302	5	19	100.8	53	67	133	3360
28.00	ZTR519SPH942_0280 ME	2800	4500	≤48	0.85	44	15	303	5	19	100.8	54	67	133	3360
28.00	ZTR519SPH942_0280 MEL	2800	4500	≤60	0.85	44	15	304	5	19	100.8	54	67	133	3360
30.00	ZTR519SPH942_0300 ME	2500	4000	≤48	0.70	44	15	301	5	19	100.8	54	67	133	3360
30.00	ZTR519SPH942_0300 MEL	2500	4000	≤60	0.70	44	15	302	5	19	100.8	54	67	133	3360
32.00	ZTR519SPH942_0320 ME	2800	4500	≤48	0.74	44	15	301	5	19	100.8	54	67	133	3360
32.00	ZTR519SPH942_0320 MEL	2800	4500	≤60	0.74	44	15	301	5	19	100.8	54	67	133	3360
40.00	ZTR519SPH942_0400 ME	2800	4500	≤48	0.59	44	15	299	5	19	100.8	54	67	133	3360
40.00	ZTR519SPH942_0400 MEL	2800	4500	≤60	0.59	44	15	299	5	19	100.8	54	67	133	3360
42.00	ZTR519SPH942_0420 ME	2800	4500	≤48	0.57	44	15	301	5	19	100.8	54	67	133	3360
42.00	ZTR519SPH942_0420 MEL	2800	4500	≤60	0.57	44	15	301	5	19	100.8	54	67	133	3360
48.00	ZTR519SPH942_0480 ME	2800	4500	≤48	0.50	44	15	300	5	19	100.8	54	67	133	3360
48.00	ZTR519SPH942_0480 MEL	2800	4500	≤60	0.50	44	15	300	5	19	100.8	54	67	133	3360
60.00	ZTR519SPH942_0600 ME	2800	4500	≤48	0.40	44	15	299	5	19	100.8	54	67	133	3360
60.00	ZTR519SPH942_0600 MEL	2800	4500	≤60	0.40	44	15	299	5	19	100.8	54	67	133	3360
ZTR6PH9 ($F_{f2acc,max} = 56$ kN)															
12.00	ZTR616SPH942_0120 ME	1800	3000	≤48	1.33	44	15	312	6	16	101.9	42	56	112	2844
12.00	ZTR616SPH942_0120 MEL	1800	3000	≤60	1.33	44	15	313	6	16	101.9	42	56	112	2844
16.00	ZTR616SPH942_0160 ME	2000	3500	≤48	1.17	44	15	311	6	16	101.9	46	56	112	2844
16.00	ZTR616SPH942_0160 MEL	2000	3500	≤60	1.17	44	15	312	6	16	101.9	46	56	112	2844
18.00	ZTR616SPH942_0180 ME	1800	3000	≤48	0.89	44	15	308	6	16	101.9	48	56	112	2844
18.00	ZTR616SPH942_0180 MEL	1800	3000	≤60	0.89	44	15	308	6	16	101.9	48	56	112	2844
20.00	ZTR616SPH942_0200 ME	2500	4000	≤48	1.07	44	15	311	6	16	101.9	49	56	112	2844
20.00	ZTR616SPH942_0200 MEL	2500	4000	≤60	1.07	44	15	311	6	16	101.9	49	56	112	2844
24.00	ZTR616SPH942_0240 ME	2000	3500	≤48	0.78	44	15	308	6	16	101.9	53	56	112	2844
24.00	ZTR616SPH942_0240 MEL	2000	3500	≤60	0.78	44	15	308	6	16	101.9	53	56	112	2844
28.00	ZTR616SPH942_0280 ME	2800	4500	≤48	0.86	44	15	310	6	16	101.9	53	56	112	2844
28.00	ZTR616SPH942_0280 MEL	2800	4500	≤60	0.86	44	15	310	6	16	101.9	53	56	112	2844
30.00	ZTR616SPH942_0300 ME	2500	4000	≤48	0.71	44	15	307	6	16	101.9	53	56	112	2844
30.00	ZTR616SPH942_0300 MEL	2500	4000	≤60	0.71	44	15	308	6	16	101.9	53	56	112	2844
32.00	ZTR616SPH942_0320 ME	2800	4500	≤48	0.75	44	15	307	6	16	101.9	53	56	112	2844
32.00	ZTR616SPH942_0320 MEL	2800	4500	≤60	0.75	44	15	307	6	16	101.9	53	56	112	2844
40.00	ZTR616SPH942_0400 ME	2800	4500	≤48	0.60	44	15	305	6	16	101.9	53	56	112	2844
40.00	ZTR616SPH942_0400 MEL	2800	4500	≤60	0.60	44	15	305	6	16	101.9	53	56	112	2844
42.00	ZTR616SPH942_0420 ME	2800	4500	≤48	0.57	44	15	307	6	16	101.9	53	56	112	2844
42.00	ZTR616SPH942_0420 MEL	2800	4500	≤60	0.57	44	15	307	6	16	101.9	53	56	112	2844
48.00	ZTR616SPH942_0480 ME	2800	4500	≤48	0.50	44	15	306	6	16	101.9	53	56	112	2844
48.00	ZTR616SPH942_0480 MEL	2800	4500	≤60	0.50	44	15	306	6	16	101.9	53	56	112	2844
60.00	ZTR616SPH942_0600 ME	2800	4500	≤48	0.40	44	15	305	6	16	101.9	53	56	112	2844
60.00	ZTR616SPH942_0600 MEL	2800	4500	≤60	0.40	44	15	305	6	16	101.9	53	56	112	2844

5.3 Dimensional drawings

In this chapter, you can find the dimensions of the rack and pinion drives with motor adapter.

Dimension a_z in the tables of dimensions applies to STOBBER gear racks. In general: $a_z = \frac{1}{2} d_0 + h_0 + x \cdot m_n$

The pinion of the rack and pinion drive is helical (left-hand $19^\circ 31' 42''$). The pinion gearing quality is 5.

Dimensions can exceed the specifications of ISO 2768-mK due to casting tolerances or accumulation of individual tolerances.

We reserve the right to make dimensional changes due to ongoing technical development.

You can download 3D models of our standard drives at <https://configurator.stoeber.de/en-US/>.

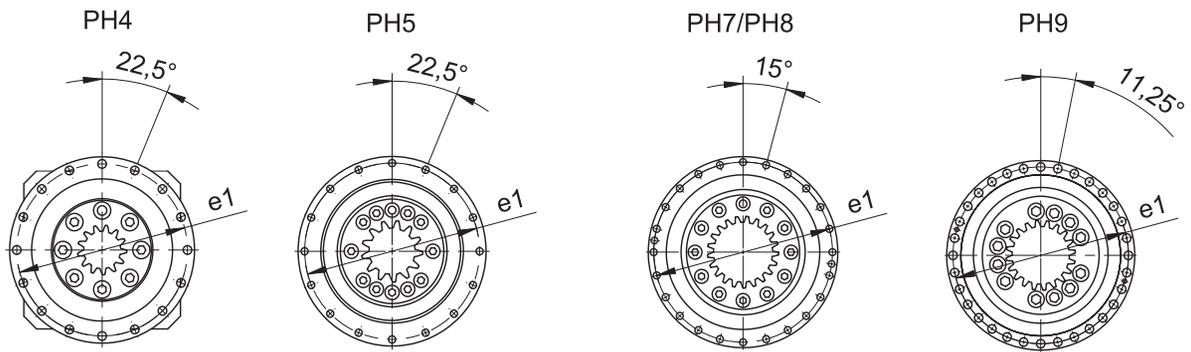
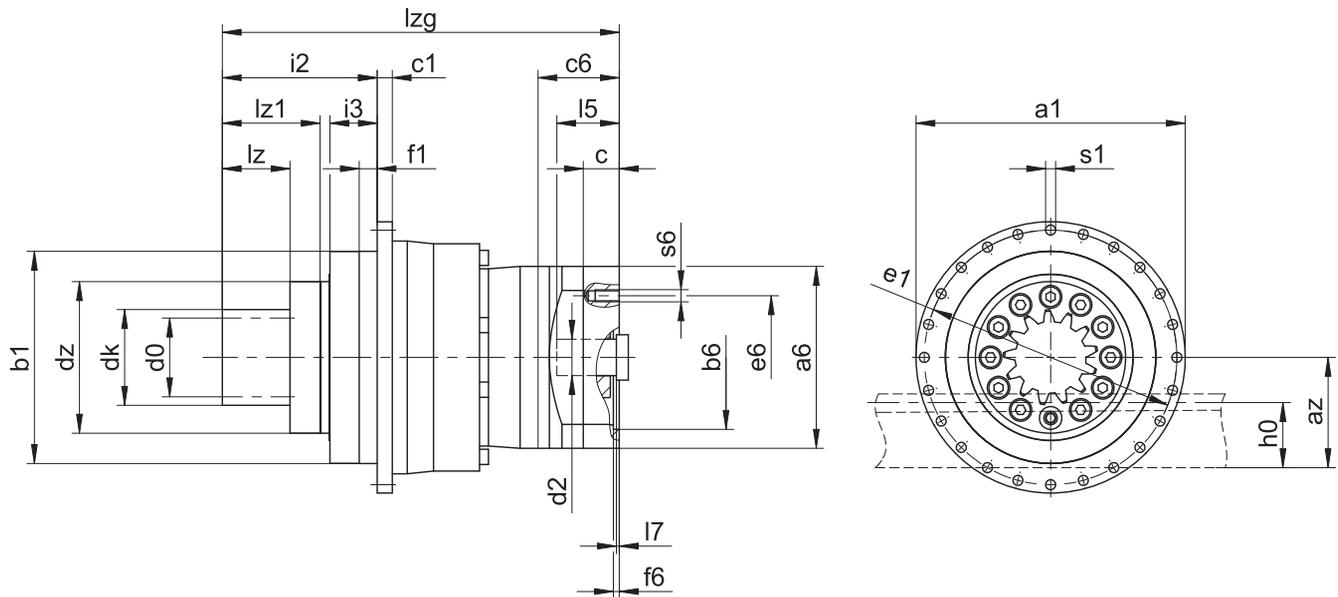

Output dimensions

Type	mn	Øa1	az	Øb1	c1	d0	dk	dz	Øe1	f1	h0	i2	i3	lz	lz1	Øs1	x
ZTR212SPH4_	2	118	35.73	90 _{h7}	7	25.47	31.5	63	109	10	22	71.0	23.5	26.0	41.0	5.5	0.50
ZTR216SPH4_	2	118	38.98	90 _{h7}	7	33.95	38.0	63	109	10	22	71.0	23.5	26.0	41.0	5.5	0.00
ZTR219SPH5_	2	145	42.16	110 _{h7}	8	40.32	44.3	80	135	12	22	70.0	22.5	26.0	41.0	5.5	0.00
ZTR223SPH5_	2	145	46.40	110 _{h7}	8	48.81	52.8	80	135	12	22	70.0	22.5	26.0	41.0	5.5	0.00
ZTR314SPH5_	3	145	49.18	110 _{h7}	8	44.56	52.4	80	135	12	26	76.5	22.5	32.5	47.5	5.5	0.30
ZTR223SPH7_	2	179	46.40	140 _{h7}	10	48.81	52.8	100	168	12	22	84.0	31.5	26.0	46.0	6.6	0.00
ZTR316SPH7_	3	179	51.46	140 _{h7}	10	50.93	56.9	100	168	12	26	90.5	31.5	32.5	52.5	6.6	0.00
ZTR319SPH7_	3	179	56.24	140 _{h7}	10	60.48	66.5	100	168	12	26	90.5	31.5	32.5	52.5	6.6	0.00
ZTR412SPH7_	4	179	62.46	140 _{h7}	10	50.93	62.9	100	168	12	35	103.0	31.5	45.0	65.0	6.6	0.50
ZTR332SPH8_	3	247	76.93	200 _{h7}	12	101.86	107.9	148	233	15	26	107.5	41.5	32.5	57.5	9.0	0.00
ZTR417SPH8_	4	247	71.08	200 _{h7}	12	72.15	80.2	148	233	15	35	120.0	41.5	45.0	70.0	9.0	0.00
ZTR420SPH8_	4	247	77.44	200 _{h7}	12	84.88	92.9	148	233	15	35	120.0	41.5	45.0	70.0	9.0	0.00
ZTR518SPH8_	5	247	81.75	200 _{h7}	12	95.49	105.5	148	233	15	34	130.0	41.5	55.0	80.0	9.0	0.00
ZTR615SPH8_	6	247	90.75	200 _{h7}	12	95.49	107.5	148	233	15	43	140.0	41.5	65.0	90.0	9.0	0.00
ZTR519SPH9_	5	300	84.40	255 _{h7}	18	100.80	110.8	187	280	20	34	155.0	54.0	55.0	89.0	13.5	0.00
ZTR616SPH9_	6	300	93.93	255 _{h7}	18	101.86	113.9	187	280	20	43	165.0	54.0	65.0	99.0	13.5	0.00

Example dimensions for the motor connection + total length

Type	Øb6	Øe6	Ød2max	l5	□a6	c	c6	f6	l7	lzg	s6
ZTR2_PH431_ME	95.0 ^{H7}	115	24	41	100	21	42.5	4.0	3.5	154.5	M8
ZTR2_PH432_ME	60.0 ^{H7}	75	19	41	75	18	41.5	3.5	4.0	191.5	M5
ZTR2_PH531_ME	110.0 ^{H7}	130	32	51	120	24	54.0	4.0	4.5	173.0	M8
ZTR3_PH531_ME	110.0 ^{H7}	130	32	51	120	24	54.0	4.0	4.5	179.5	M8
ZTR2_PH532_ME	95.0 ^{H7}	115	24	41	100	21	42.5	4.0	3.5	202.0	M8
ZTR3_PH532_ME	95.0 ^{H7}	115	24	41	100	21	42.5	4.0	3.5	208.5	M8
ZTR2_PH731_ME	130.0 ^{H7}	165	38	61	150	26	66.0	5.5	4.5	207.0	M10
ZTR3_PH731_ME	130.0 ^{H7}	165	38	61	150	26	66.0	5.5	4.5	213.5	M10
ZTR4_PH731_ME	130.0 ^{H7}	165	38	61	150	26	66.0	5.5	4.5	226.0	M10
ZTR2_PH732_ME	110.0 ^{H7}	130	32	51	120	24	54.0	4.0	4.5	245.0	M8
ZTR3_PH732_ME	110.0 ^{H7}	130	32	51	120	24	54.0	4.0	4.5	251.5	M8
ZTR4_PH732_ME	110.0 ^{H7}	130	32	51	120	24	54.0	4.0	4.5	264.0	M8
ZTR3_PH831_ME	180.0 ^{H7}	215	48	83	204	35	80.5	5.5	8.5	275.5	M12
ZTR4_PH831_ME	180.0 ^{H7}	215	48	83	204	35	80.5	5.5	8.5	288.0	M12
ZTR5_PH831_ME	180.0 ^{H7}	215	48	83	204	35	80.5	5.5	8.5	298.0	M12
ZTR6_PH831_ME	180.0 ^{H7}	215	48	83	204	35	80.5	5.5	8.5	308.0	M12
ZTR3_PH832_ME	130.0 ^{H7}	165	38	61	150	26	66.0	5.5	4.5	320.5	M10
ZTR4_PH832_ME	130.0 ^{H7}	165	38	61	150	26	66.0	5.5	4.5	333.0	M10
ZTR5_PH832_ME	130.0 ^{H7}	165	38	61	150	26	66.0	5.5	4.5	343.0	M10
ZTR6_PH832_ME	130.0 ^{H7}	165	38	61	150	26	66.0	5.5	4.5	353.0	M10
ZTR5_PH942_ME	180.0 ^{H7}	215	48	83	204	35	80.5	5.5	8.5	423.5	M12
ZTR6_PH942_ME	180.0 ^{H7}	215	48	83	204	35	80.5	5.5	8.5	433.5	M12

In the table above, you will find example dimensions for the motor connection for the ME motor adapter.

Note that when dimension c is lengthened, dimensions c6, l5 and lzg are also lengthened accordingly.

You will find additional motor connection dimensions for motor adapters ME, MEL and MF in our STÖBER Configurator at <https://configurator.stoeber.de/en-US/>. Here, you can directly download a 3D model of your drive.

5.4 Type designation

This chapter shows you an explanation of the type designation with the associated options.

Additional ordering information not included in the type designation can be found at the end of the chapter.

Example code

Z	TR	3	19	S	PH	7	3	1	S	F	S	S	0050	ME
---	----	---	----	---	----	---	---	---	---	---	---	---	------	----

Explanation

Code	Designation	Design
Z	Type	Rack and pinion drive
TR	Design	Screwed flange pinion
3	Normal module	$m_n = 3$ mm (example)
19	Number of teeth	$z = 19$ (example)
S	Toothing	Helical (left-hand 19° 31' 42")
PH	Type	Planetary gear unit
7	Size	7 (example)
3	Generation	Generation 3
4		Generation 4
1	Stages	Single-stage
2		Two-stage
S	Housing	Standard
F	Shaft	Flange shaft
S	Bearing	Standard bearing
V		Reinforced bearing (PH3 – PH5)
S	Backlash	Standard
R		Reduced
0050	Transmission ratio ($i \times 10$)	$i = 5$ (example)
ME	Motor adapter	Motor adapter with EasyAdapt coupling
MEL		Motor adapter with EasyAdapt coupling for large motors
MF		Motor adapter with FlexiAdapt coupling
MB ¹		ServoStop motor adapter with brake

To complete the type designation, also specify the following in your order:

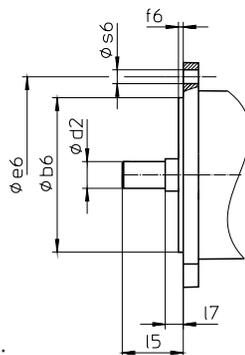

- Motor type or motor dimensions:

To choose a suitable motor connection, use the STOBER Configurator at

<https://configurator.stoeber.de/en-US/> and choose your motor or the dimensions of the motor connection.

- Radial shaft seal rings at the output made of NBR or FKM (option), see the chapter [▶ 5.6.3]
- Radial runout $\leq 10 \mu\text{m}$ (optional)
- Reverse operation of the output shaft from $\pm 20^\circ$ to $\pm 90^\circ$ for horizontal installation on request
- PH531, PH7 – PH9: Double seal for motor adapter (option)
- Socket wrench insert for mounting the motor on the gear unit using the ME/MEL/MF motor adapter (option)

In this product catalog, you will find all the information about rack and pinion drives with a motor adapter. All input options available upon request are listed in the chapter [▶ 5.5.1].

5.4.1 Nameplate

An example gear unit nameplate is explained in the figure below.

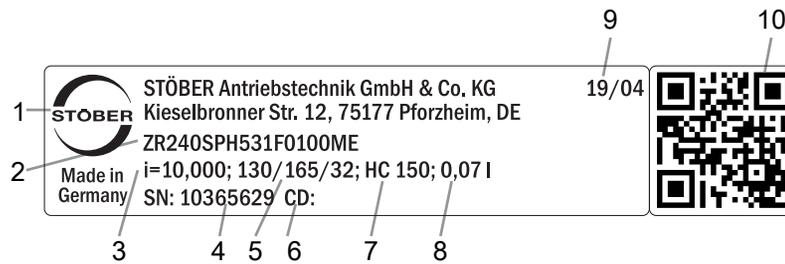

Code	Designation
1	Name of manufacturer
2	Type designation
3	Gear ratio of the gear unit
4	Serial number of the gear unit
5	Dimensions of the motor adapter (pilot/bolt circle/motor shaft diameter)
6	Customer-specific data
7	Lubricant specification
8	Lubricant fill volume
9	Date of manufacture (year/calendar week)
10	QR code (link to product information)

5.4.1.1 Supporting documents

You can view or download supporting documents for the product by reading off the serial number on the nameplate of the product and entering it at the following address online:

<https://id.stober.com>

Alternatively, you can use a suitable mobile device to scan in the QR code on the nameplate of the product in order to be linked to the supporting documents.

5.5 Product description

5.5.1 Input options

In this chapter, you will find all available input options:

Motor adapter



Catalog ID 443137_en

EZ synchronous servo motor



Catalog ID 443286_en

KX right-angle input with MF motor adapter



On request

K right-angle input with ME motor adapter



On request

MB motor adapter



On request

The corresponding catalogs can be found at <http://www.stober.de/en/downloads/>

Enter the ID of the catalog in the Search term field.

5.5.2 Motor adapter with EasyAdapt coupling (ME/MEL)

In this chapter, you will find a description of the EasyAdapt coupling.

Properties:

- Fast and easy motor attachment
- One-piece, rugged clamp coupling with expanding function
- Lowest mass moments of inertia for the highest dynamics
- Balanced for smooth running without vibration, even at high speeds
- Large selection of motor shaft diameters and lengths
- Error-free, thanks to exact centering of the motor
- For reduced backlash, the motor shaft bearing must have an axially backlash-free design



Fig. 1: EasyAdapt coupling

5.5.3 Motor adapter with FlexiAdapt coupling (MF)

In this chapter, you will find a description of the FlexiAdapt coupling.

Properties:

- Fast and easy motor attachment
- Rugged, laser-welded bellow coupling with expanding function
- With integrated thermal length compensation, compensates for linear expansion of the motor shaft
- Motor shaft decoupled from axial forces
- Balanced for smooth running without vibration, even at high speeds
- Large selection of motor shaft diameters and lengths
- Error-free, thanks to exact centering of the motor



Fig. 2: FlexiAdapt coupling

5.5.4 Gear rack

The gear rack used must have a right-hand design (19° 31' 42"); the load capacity must not be exceeded.

When using a STÖBER gear rack, please also observe the project configuration in the chapter [▶ 13.6](#).

5.5.5 Installation conditions

The torque and force values listed in this catalog are valid under the following conditions:

- When the gear housing is fastened on the machine side using screws of strength class 12.9
- When the gear housings are adjusted at pilot \varnothing bz. The machine-side fit must be H7.

5.5.6 Lubricants

STÖBER fills the gear units with the amount and type of lubricant specified on the nameplate.

You will receive lubricants for use in the food industry upon request.

5.5.6.1 Rack and pinion drive lubrication

Ensure permanent lubrication with the lubricants recommended in the chapter [▶ 13.5.1](#).

5.5.7 Other product features

Feature	Value
Max. permitted gear unit temperature (on the surface of the gear unit)	≤ 90 °C
Paint	Black RAL 9005
(ATEX) Directive 2014/34/EU (optional)	Not suitable.
Protection class: ²	
Planetary gear unit	IP65
Pinion/gear rack	IPXX

5.5.8 Direction of rotation

The input and output rotate in the same direction.

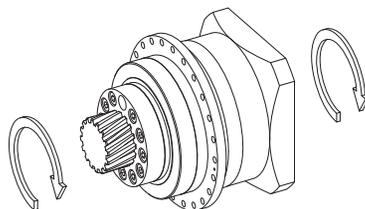

²Observe the protection class of all the components.

5.6 Project configuration

Project your drives using our SERVOfsoft designing software. Download SERVOfsoft free of charge after registration at <https://www.stoeber.de/en/services/info-servosoft/>.

It is the most convenient and reliable method of drive selection, as the entire torque/speed curve of the application is displayed and evaluated here in the curve of the geared motor.

In this chapter, only limit values for specific operating points can be taken into consideration for manual drive selection.

The formula symbols for values actually present in the application are marked with *.

An explanation of the formula symbols can be found in the chapter [▶ 14.1](#).

5.6.1 Drive selection

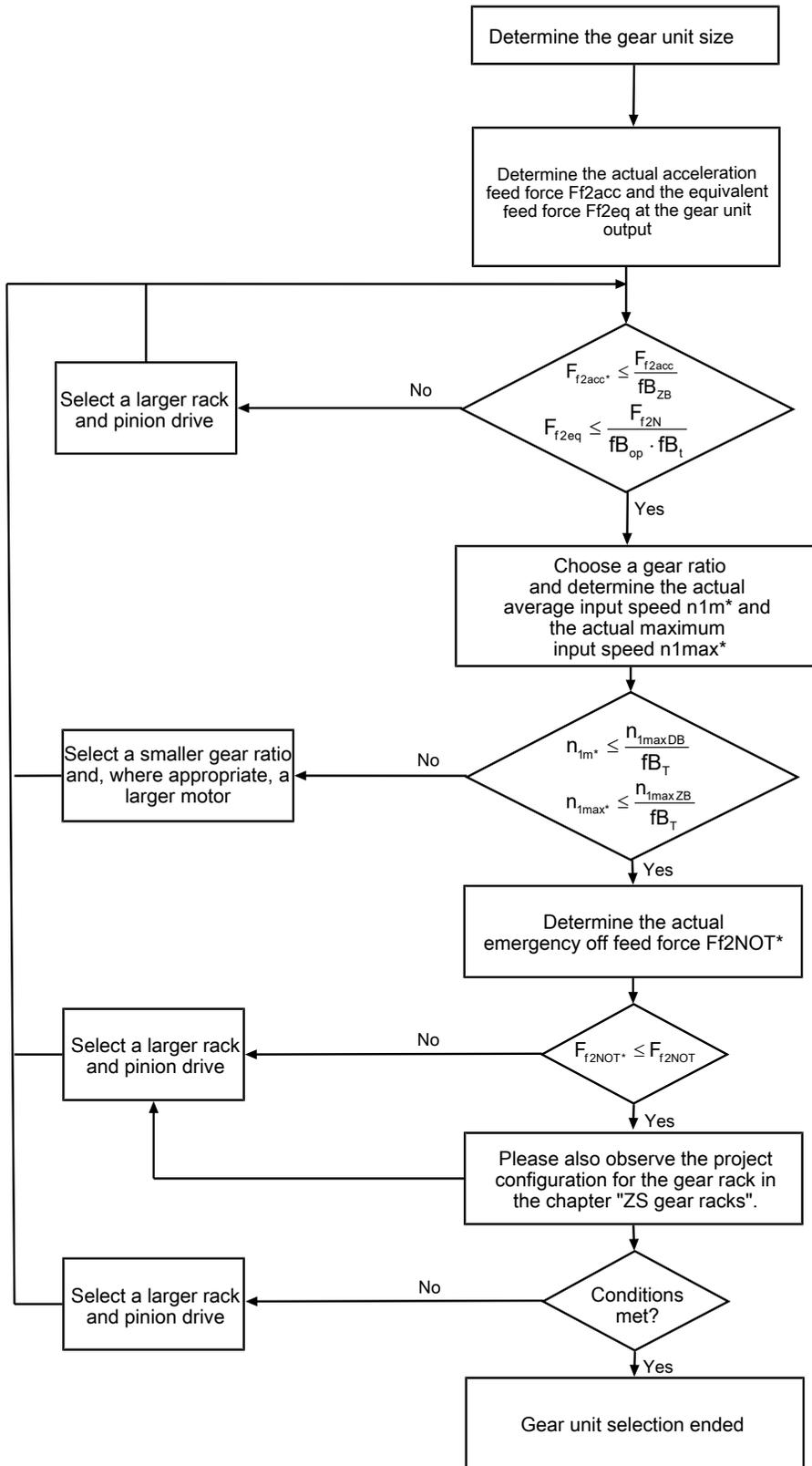

Refer to the selection tables for the values for i , n_{1maxDB} , n_{1maxZB} , F_{f2acc} , F_{f2N} and F_{f2NOT} .

The values for f_{B_T} , $f_{B_{op}}$, f_{B_t} and $f_{B_{zB}}$ can be found in the corresponding tables in this chapter.

Example of cyclic operation

The following calculations are based on a representation of the power taken from the output based in accordance with the following example:

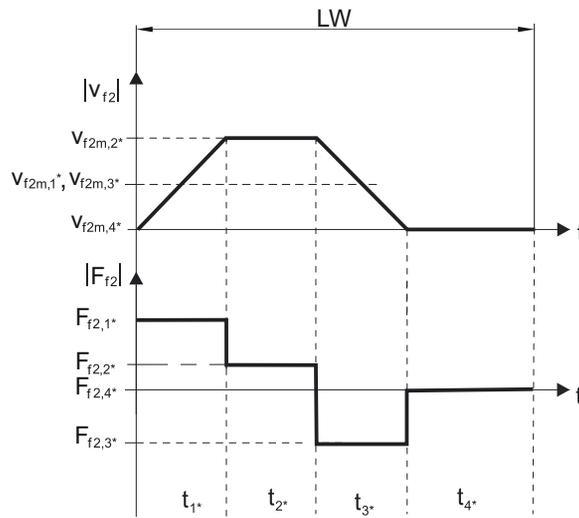

Calculation of the actual maximum acceleration feed force

$$F_{f2acc} = m \cdot a^* + F_L^*$$

Calculation of the actual average input speed

$$n_{1m} = \frac{v_{f2m} \cdot i}{d_0 \cdot \pi}$$

$$v_{f2m} = \frac{|v_{f2m,1}| \cdot t_1 + \dots + |v_{f2m,n}| \cdot t_n}{t_1 + \dots + t_n}$$

If $t_1 + \dots + t_3 \geq 6$ min, determine v_{2m} without the rest phase t_4 .

The values for the ratio i can be found in the selection tables.

Calculation of the actual emergency off feed force

$$F_{f2NOT} = m \cdot a_{NOT} + F_L^*$$

Calculation of the actual equivalent feed force

$$F_{f2eq} = \sqrt[3]{\frac{|v_{f2m,1}| \cdot t_1 \cdot |F_{f2,1}|^3 + \dots + |v_{f2m,n}| \cdot t_n \cdot |F_{f2,n}|^3}{|v_{f2m,1}| \cdot t_1 + \dots + |v_{f2m,n}| \cdot t_n}}$$

Operating factors

Operating mode	fB_{op}
Uniform continuous operation	1.00
Cyclic operation	1.00
Reversing load cyclic operation	1.00
Run time	fB_t
Daily runtime ≤ 8 h	1.00
Daily runtime ≤ 16 h	1.15
Daily runtime ≤ 24 h	1.20
Cyclic operation	fB_{ZB}
≤ 1000 load changes/hour (LW/h)	1.00
> 1000 load changes/hour (LW/h)	1.15

Temperature		f_{B_T}
Motor cooling	Surrounding temperature	
Motor with forced ventilation	$\leq 20\text{ °C}$	0.9
	$\leq 30\text{ °C}$	1.0
	$\leq 40\text{ °C}$	1.15
Motor with convection cooling	$\leq 20\text{ °C}$	1.0
	$\leq 30\text{ °C}$	1.1
	$\leq 40\text{ °C}$	1.25

Notes

- The maximum permitted gear unit temperature (see the "Other product features" chapter) must not be exceeded, as that could result in damage.
- For braking from full speed (for example, when the power fails or when setting up the machine), note the permitted gear unit feed forces (F_{f2acc} , F_{f2NOT}) in the selection tables.

5.6.2 Permitted breakdown torques at the gear unit input

For a horizontal mounting position of the motor, verify that the permitted breakdown torque at the gear unit input is not exceeded before installation on a STOBBER gear unit. You can find information for how to do that in this chapter.

Calculate the actual breakdown torque as follows:

$$M_{1k^*} = F_{1k^*} \cdot l_{sp} \leq M_{1k}$$

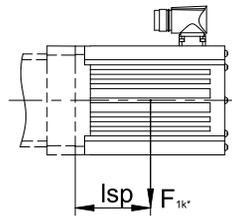

Type	M_{1k} [Nm]
PH331_ME	20
PH332_ME	10
PH431_ME	40
PH432_ME	20
PH531_ME	80
PH532_ME	40
PH731_ME	200
PH732_ME	80
PH831_ME	400
PH832_ME	200
PH942_ME	400
PH1042_ME	400

The values also apply to the MEL and MF motor adapters.

5.6.3 Recommendation for radial shaft seal rings

For a duty cycle > 60% and higher surrounding temperatures, we recommend radial shaft seal rings made of FKM at the output.

Properties:

- Excellent temperature resistance
- High chemical stability
- Very good resistance to aging
- Excellent resistance in oils and greases
- For use in the food, beverage and pharmaceutical industries

Leak-proofness

Our gear units are equipped with high-quality radial shaft seal rings and checked for leaks. However, a leak cannot be fully ruled out over the length of use of a gear unit. If you use a gear unit with goods incompatible with the lubricant, you must take measures to prevent direct contact with the gear unit lubricant in case of a leak.

5.7 Additional documentation

Additional documentation related to the product can be found at

<http://www.stoeber.de/en/downloads/>

Enter the ID of the documentation in the Search term field.

Documentation	ID
Operating manual gear units, geared motors PH33 – PH83, PH94 – PH104	443354_en
Operating manual gear racks	443392_en

6 ZTRPHV rack and pinion drives

Table of contents

6.1	Overview	78
6.2	Selection tables	79
6.3	Dimensional drawings	80
6.4	Type designation	81
6.4.1	Nameplate	82
6.5	Product description	82
6.5.1	Input options	82
6.5.2	Motor adapter with EasyAdapt coupling (ME/MEL)	83
6.5.3	Gear rack	83
6.5.4	Installation conditions	83
6.5.5	Lubricants	83
6.5.6	Other product features	83
6.5.7	Direction of rotation	84
6.6	Project configuration	84
6.6.1	Drive selection	85
6.6.2	Permitted breakdown torques at the gear unit input	87
6.6.3	Recommendation for radial shaft seal rings	87
6.7	Additional documentation	88



6 Rack and pinion drives

ZTRPHV

6.1 Overview

High-performance precision planetary gear units with screwed flange pinion

Features

Power density	★★★★☆
Linear clearance	★★★★☆
Price category	€€€€
Smooth operation	★★★★☆
Linear rigidity	★★★★☆
Mass moment of inertia	★★★★☆
Ready-to-install drive solution	✓
Pinion gearing quality 5 (DIN 3962)	✓
Helical gearing	✓
Case-hardened and smoothed	✓
Radial runout ≤ 10 μm (optional)	✓

Key ★☆☆☆☆ good | ★★★★★ excellent
 € Economy | €€€€€ Premium

Technical data

m_n	5 – 6 mm
z	16 – 19
F_{f2acc}	56 – 67 kN
$V_{f2maxzB}$	0.2 – 0.39 m/s
Δs	15 – 44 μm

6.2 Selection tables

The technical data specified in the selection tables applies to:

- De-energized installation
- Permanent lubrication with the lubricants recommended in the chapter on gear racks ▶ 13.5.1]
- Case-hardened pinions, helical (left-hand 19° 31' 42"), gearing quality 5
- Installation altitudes up to 1000 m above sea level
- Surrounding temperatures from 0 °C to 40 °C
- Without consideration of the thermal limiting performance

For all other technical data, refer to <https://configurator.stoeber.de/en-US/>.

An explanation of the formula symbols can be found in the chapter ▶ 14.1].

i	Type	$n_{1\max DB}$ [rpm]	$n_{1\max ZB}$ [rpm]	d_{MW} [mm]	$v_{f2\max ZB}$ [m/s]	Δs [μm]	Δs_{red} [μm]	C_{lin} [N/μm]	m_n [mm]	z	d_0 [mm]	F_{f2N} [kN]	F_{f2acc} [kN]	F_{f2NOT} [kN]	M_{2acc} [Nm]
ZTR5PHV9 ($F_{f2acc,max} = 67$ kN)															
61.00	ZTR519SPHV943_0610 ME	2500	4500	≤38	0.39	44	15	284	5	19	100.8	50	67	133	3360
61.00	ZTR519SPHV943_0610 MEL	2500	4500	≤48	0.39	44	15	284	5	19	100.8	50	67	133	3360
91.00	ZTR519SPHV943_0910 ME	2500	4500	≤38	0.26	44	15	283	5	19	100.8	50	67	133	3360
91.00	ZTR519SPHV943_0910 MEL	2500	4500	≤48	0.26	44	15	283	5	19	100.8	50	67	133	3360
121.0	ZTR519SPHV943_1210 ME	2500	4500	≤38	0.20	44	15	280	5	19	100.8	50	67	133	3360
121.0	ZTR519SPHV943_1210 MEL	2500	4500	≤48	0.20	44	15	280	5	19	100.8	50	67	133	3360
ZTR6PHV9 ($F_{f2acc,max} = 56$ kN)															
61.00	ZTR616SPHV943_0610 ME	2500	4500	≤38	0.39	44	15	289	6	16	101.9	49	56	112	2844
61.00	ZTR616SPHV943_0610 MEL	2500	4500	≤48	0.39	44	15	289	6	16	101.9	49	56	112	2844
91.00	ZTR616SPHV943_0910 ME	2500	4500	≤38	0.26	44	15	288	6	16	101.9	49	56	112	2844
91.00	ZTR616SPHV943_0910 MEL	2500	4500	≤48	0.26	44	15	288	6	16	101.9	49	56	112	2844
121.0	ZTR616SPHV943_1210 ME	2500	4500	≤38	0.20	44	15	285	6	16	101.9	49	56	112	2844
121.0	ZTR616SPHV943_1210 MEL	2500	4500	≤48	0.20	44	15	285	6	16	101.9	49	56	112	2844

6.3 Dimensional drawings

In this chapter, you can find the dimensions of the rack and pinion drives with motor adapter.

Dimension az in the tables of dimensions applies to STÖBER gear racks. In general: $az = \frac{1}{2} d_0 + h_0 + x \cdot mn$

The pinion of the rack and pinion drive is helical (left-hand 19° 31' 42"). The pinion gearing quality is 5.

Dimensions can exceed the specifications of ISO 2768-mK due to casting tolerances or accumulation of individual tolerances.

We reserve the right to make dimensional changes due to ongoing technical development.

You can download 3D models of our standard drives at <https://configurator.stoeber.de/en-US/>.

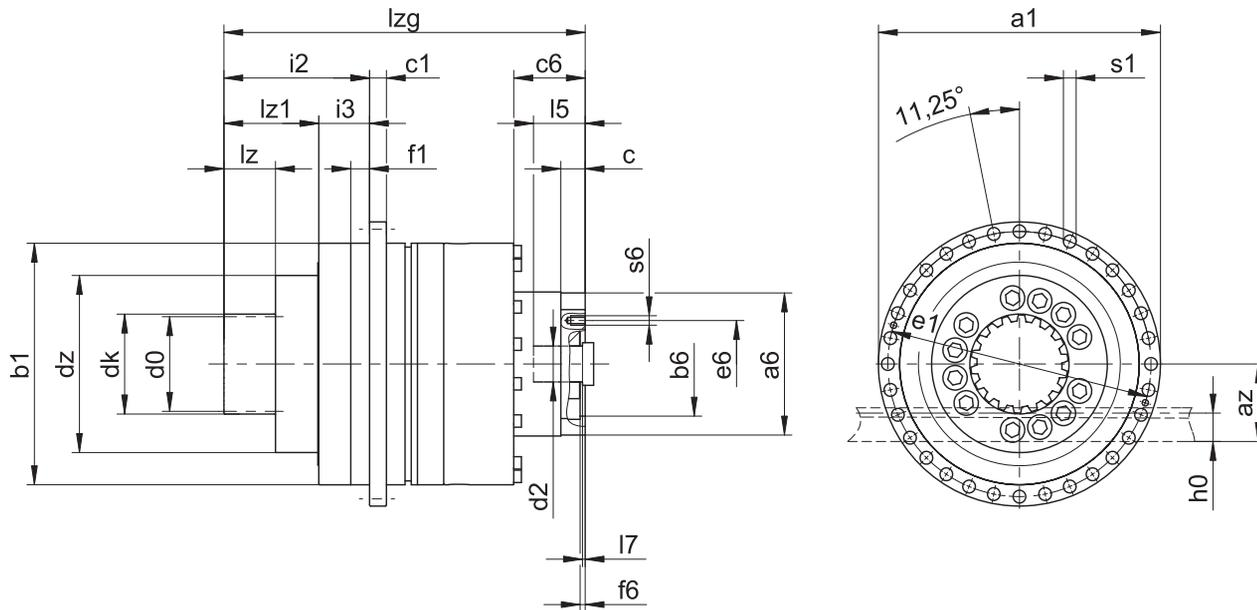

Output dimensions

Type	mn	Øa1	az	Øb1	c1	d0	dk	dz	Øe1	f1	h0	i2	i3	lz	lz1	Øs1	x
ZTR519SPHV9_	5	300	84.40	255 _{h7}	18	100.80	110.8	187	280	20	34	155	54	55	101	13.5	0.0
ZTR616SPHV9_	6	300	93.93	255 _{h7}	18	101.86	113.9	187	280	20	43	165	54	65	111	13.5	0.0

Example dimensions for the motor connection + total length

Type	Øb6	Øe6	Ød2max	l5	□a6	c	c6	f6	l7	lzg	s6
ZTR5_PHV9_ME	130.0 ^{H7}	165	38	61	150	26	66	5.5	4.5	383	M10
ZTR6_PHV9_ME	130.0 ^{H7}	165	38	61	150	26	66	5.5	4.5	393	M10

In the table above, you will find example dimensions for the motor connection for the ME motor adapter.

Note that when dimension c is lengthened, dimensions c6, l5 and lzg are also lengthened accordingly.

You will find additional motor connection dimensions for motor adapters ME and MEL in our STÖBER Configurator at <https://configurator.stoeber.de/en-US/>. Here, you can directly download a 3D model of your drive.

6.4 Type designation

This chapter shows you an explanation of the type designation with the associated options.

Additional ordering information not included in the type designation can be found at the end of the chapter.

Example code

Z	TR	6	16	S	PHV	9	4	3	S	F	S	S	0910	ME
---	----	---	----	---	-----	---	---	---	---	---	---	---	------	----

Explanation

Code	Designation	Design
Z	Type	Rack and pinion drive
TR	Design	Screwed flange pinion
6	Normal module	$m_n = 6$ mm (example)
16	Number of teeth	$z = 16$ (example)
S	Toothing	Helical (left-hand 19° 31' 42")
PHV	Type	Planetary gear unit
9	Size	9 (example)
4	Generation	Generation 4
3	Stages	Three-stage
S	Housing	Standard
F	Shaft	Flange shaft
S	Bearing	Standard bearing
S	Backlash	Standard
R		Reduced (PHV9)
0910	Transmission ratio ($i \times 10$)	$i = 91$ (example)
ME	Motor adapter	Motor adapter with EasyAdapt coupling
MEL		Motor adapter with EasyAdapt coupling for large motors
MB ¹		ServoStop motor adapter with brake

To complete the type designation, also specify the following in your order:

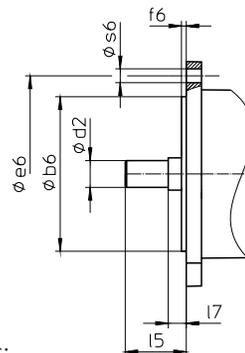

- Motor type or motor dimensions:

To choose a suitable motor connection, use the STOBBER Configurator at

<https://configurator.stoeber.de/en-US/> and choose your motor or the dimensions of the motor connection.

- Radial shaft seal rings at the output made of NBR or FKM (option), see the chapter [▶ 6.6.3](#)
- Radial runout $\leq 10 \mu\text{m}$ (optional)
- Reverse operation of the output shaft from $\pm 20^\circ$ to $\pm 90^\circ$ for horizontal installation on request
- Double seal for motor adapter (option)
- Socket wrench insert for mounting the motor on the gear unit using the ME/MEL motor adapter (optional)

In this product catalog, you will find all the information about rack and pinion drives with a motor adapter.

All input options available upon request are listed in the chapter [▶ 6.5.1](#).

¹You can find more details in the catalog for ServoStop servo gear unit with brake ID 443234.

6.4.1 Nameplate

An example gear unit nameplate is explained in the figure below.

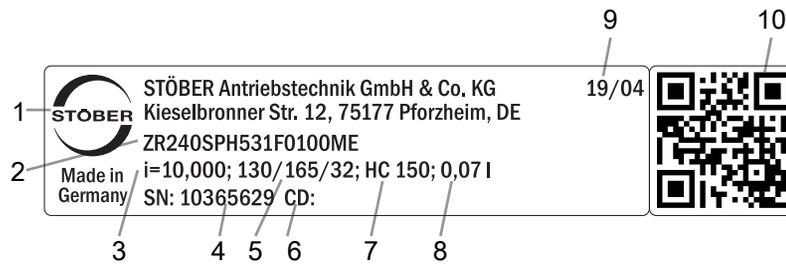

Code	Designation
1	Name of manufacturer
2	Type designation
3	Gear ratio of the gear unit
4	Serial number of the gear unit
5	Dimensions of the motor adapter (pilot/bolt circle/motor shaft diameter)
6	Customer-specific data
7	Lubricant specification
8	Lubricant fill volume
9	Date of manufacture (year/calendar week)
10	QR code (link to product information)

6.4.1.1 Supporting documents

You can view or download supporting documents for the product by reading off the serial number on the nameplate of the product and entering it at the following address online:

<https://id.stober.com>

Alternatively, you can use a suitable mobile device to scan in the QR code on the nameplate of the product in order to be linked to the supporting documents.

6.5 Product description

6.5.1 Input options

In this chapter, you will find all available input options:

Motor adapter



Catalog ID 443137_en

EZ synchronous servo motor



Catalog ID 443286_en

The corresponding catalogs can be found at <http://www.stober.de/en/downloads/>

Enter the ID of the catalog in the Search term field.

6.5.2 Motor adapter with EasyAdapt coupling (ME/MEL)

In this chapter, you will find a description of the EasyAdapt coupling.

Properties:

- Fast and easy motor attachment
- One-piece, rugged clamp coupling with expanding function
- Lowest mass moments of inertia for the highest dynamics
- Balanced for smooth running without vibration, even at high speeds
- Large selection of motor shaft diameters and lengths
- Error-free, thanks to exact centering of the motor
- For reduced backlash, the motor shaft bearing must have an axially backlash-free design



Fig. 1: EasyAdapt coupling

6.5.3 Gear rack

The gear rack used must have a right-hand design (19° 31' 42"); the load capacity must not be exceeded.

When using a STOBBER gear rack, please also observe the project configuration in the chapter [\[▶ 13.6\]](#).

6.5.4 Installation conditions

The torque and force values listed in this catalog are valid under the following conditions:

- When the gear housing is fastened on the machine side using screws of strength class 12.9
- When the gear housings are adjusted at pilot \varnothing bz. The machine-side fit must be H7.

6.5.5 Lubricants

STOBBER fills the gear units with the amount and type of lubricant specified on the nameplate.

You will receive lubricants for use in the food industry upon request.

6.5.5.1 Rack and pinion drive lubrication

Ensure permanent lubrication with the lubricants recommended in the chapter [\[▶ 13.5.1\]](#).

6.5.6 Other product features

Feature	Value
Max. permitted gear unit temperature (on the surface of the gear unit)	≤ 90 °C
Paint	Black RAL 9005
(ATEX) Directive 2014/34/EU (optional)	Not suitable.
Protection class: ²	
Planetary gear unit	IP65
Pinion/gear rack	IPXX

²Observe the protection class of all the components.

6.5.7 Direction of rotation

The input and output rotate in the same direction.

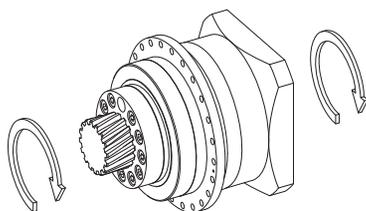

6.6 Project configuration

Project your drives using our SERVOfsoft designing software. Download SERVOfsoft free of charge after registration at <https://www.stoeber.de/en/services/info-servosoft/>.

It is the most convenient and reliable method of drive selection, as the entire torque/speed curve of the application is displayed and evaluated here in the curve of the geared motor.

In this chapter, only limit values for specific operating points can be taken into consideration for manual drive selection.

The formula symbols for values actually present in the application are marked with *.

An explanation of the formula symbols can be found in the chapter [▶ 14.1].

6.6.1 Drive selection

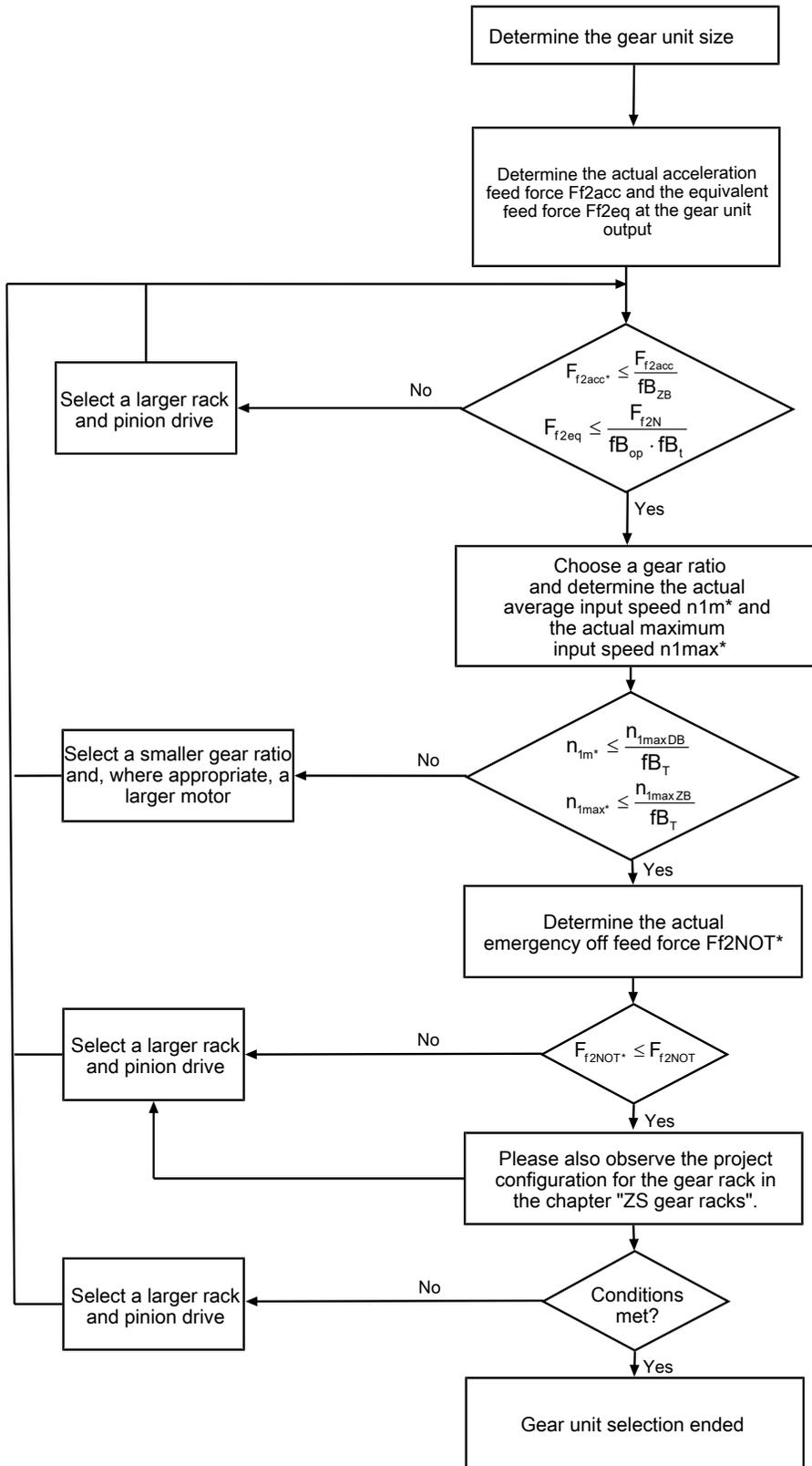

Refer to the selection tables for the values for i , n_{1maxDB} , n_{1maxZB} , F_{f2acc} , F_{f2N} and F_{f2NOT} .

The values for f_{B_T} , $f_{B_{op}}$, f_{B_t} and $f_{B_{zB}}$ can be found in the corresponding tables in this chapter.

Example of cyclic operation

The following calculations are based on a representation of the power taken from the output based in accordance with the following example:

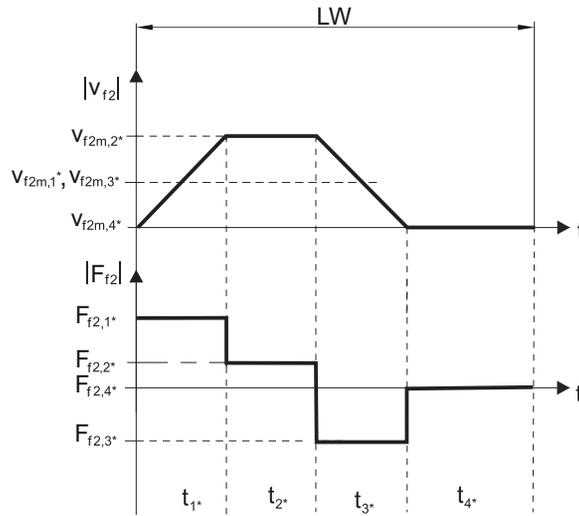

Calculation of the actual maximum acceleration feed force

$$F_{f2acc} = m \cdot a + F_L$$

Calculation of the actual average input speed

$$n_{im} = \frac{v_{f2m} \cdot i}{d_0 \cdot \pi}$$

$$v_{f2m} = \frac{|v_{f2m,1}| \cdot t_1 + \dots + |v_{f2m,n}| \cdot t_n}{t_1 + \dots + t_n}$$

If $t_1 + \dots + t_3 \geq 6$ min, determine v_{2m} without the rest phase t_4 .

The values for the ratio i can be found in the selection tables.

Calculation of the actual emergency off feed force

$$F_{f2NOT} = m \cdot a_{NOT} + F_L$$

Calculation of the actual equivalent feed force

$$F_{f2eq} = \sqrt[3]{\frac{|v_{f2m,1}| \cdot t_1 \cdot |F_{f2,1}|^3 + \dots + |v_{f2m,n}| \cdot t_n \cdot |F_{f2,n}|^3}{|v_{f2m,1}| \cdot t_1 + \dots + |v_{f2m,n}| \cdot t_n}}$$

Operating factors

Operating mode	fB_{op}
Uniform continuous operation	1.00
Cyclic operation	1.00
Reversing load cyclic operation	1.00
Run time	fB_t
Daily runtime ≤ 8 h	1.00
Daily runtime ≤ 16 h	1.15
Daily runtime ≤ 24 h	1.20
Cyclic operation	fB_{ZB}
≤ 1000 load changes/hour (LW/h)	1.00
> 1000 load changes/hour (LW/h)	1.15

Temperature		f_{B_T}
Motor cooling	Surrounding temperature	
Motor with forced ventilation	$\leq 20\text{ °C}$	0.9
	$\leq 30\text{ °C}$	1.0
	$\leq 40\text{ °C}$	1.15
Motor with convection cooling	$\leq 20\text{ °C}$	1.0
	$\leq 30\text{ °C}$	1.1
	$\leq 40\text{ °C}$	1.25

Notes

- The maximum permitted gear unit temperature (see the "Other product features" chapter) must not be exceeded, as that could result in damage.
- For braking from full speed (for example, when the power fails or when setting up the machine), note the permitted gear unit feed forces (F_{f2acc} , F_{f2NOT}) in the selection tables.

6.6.2 Permitted breakdown torques at the gear unit input

For a horizontal mounting position of the motor, verify that the permitted breakdown torque at the gear unit input is not exceeded before installation on a STOBBER gear unit. You can find information for how to do that in this chapter.

Calculate the actual breakdown torque as follows:

$$M_{1k^*} = F_{1k^*} \cdot l_{sp} \leq M_{1k}$$

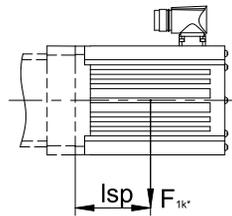

Type	M_{1k} [Nm]
PHV943_ME	200
PHV1043_ME	400

The values also apply to the MEL motor adapter.

6.6.3 Recommendation for radial shaft seal rings

For a duty cycle > 60% and higher surrounding temperatures, we recommend radial shaft seal rings made of FKM at the output.

Properties:

- Excellent temperature resistance
- High chemical stability
- Very good resistance to aging
- Excellent resistance in oils and greases
- For use in the food, beverage and pharmaceutical industries

Leak-proofness

Our gear units are equipped with high-quality radial shaft seal rings and checked for leaks. However, a leak cannot be fully ruled out over the length of use of a gear unit. If you use a gear unit with goods incompatible with the lubricant, you must take measures to prevent direct contact with the gear unit lubricant in case of a leak.

6.7 Additional documentation

Additional documentation related to the product can be found at

<http://www.stoeber.de/en/downloads/>

Enter the ID of the documentation in the Search term field.

Documentation	ID
Operating manual gear units, geared motors PHV94 – PHV104	443355_en
Operating manual gear racks	443392_en

7 ZRPH rack and pinion drives

Table of contents

7.1	Overview	90
7.2	Selection tables	91
7.3	Dimensional drawings	94
7.4	Type designation	96
7.4.1	Nameplate	97
7.5	Product description	97
7.5.1	Input options	97
7.5.2	Motor adapter with EasyAdapt coupling (ME/MEL)	98
7.5.3	Motor adapter with FlexiAdapt coupling (MF)	98
7.5.4	Gear rack	99
7.5.5	Installation conditions	99
7.5.6	Lubricants	99
7.5.7	Other product features	99
7.5.8	Direction of rotation	99
7.6	Project configuration	100
7.6.1	Drive selection	101
7.6.2	Permitted breakdown torques at the gear unit input	103
7.6.3	Recommendation for radial shaft seal rings	104
7.7	Additional documentation	104



7 Rack and pinion drives

ZRPH

7.1 Overview

High-performance precision planetary gear units with screwed pinion

Features

Power density	★★★★☆
Linear clearance	★★★★★
Price category	€€€
Smooth operation	★★★★☆
Linear rigidity	★★★★☆
Mass moment of inertia	★★★★☆
Ready-to-install drive solution	✓
Pinion gearing quality 5 (DIN 3962)	✓
Helical gearing	✓
Case-hardened and smoothed	✓
Reinforced output bearing (PH3 – PH5)	✓ (optional)

Key ★☆☆☆☆ good | ★★★★★ excellent
 € Economy | €€€€€ Premium

Technical data

m_n	2 – 4 mm
z	30 – 40
F_{f2acc}	3.1 – 16 kN
$v_{f2maxZB}$	0.29 – 6.7 m/s
Δs	10 – 56 μm

7.2 Selection tables

The technical data specified in the selection tables applies to:

- De-energized installation
- Permanent lubrication with the lubricants recommended in the chapter on gear racks ▶ 13.5.1]
- Case-hardened pinions, helical (left-hand 19° 31' 42"), gearing quality 5
- Installation altitudes up to 1000 m above sea level
- Surrounding temperatures from 0 °C to 40 °C
- Without consideration of the thermal limiting performance

For rack and pinion drives with reduced backlash or reinforced bearings (PH3 – PH5), higher feed forces are possible. For this and all other technical data, refer to <https://configurator.stoeber.de/en-US/>.

An explanation of the formula symbols can be found in the chapter ▶ 14.1].

i	Type	$n_{1\max DB}$ [rpm]	$n_{1\max ZB}$ [rpm]	d_{MW} [mm]	$v_{f2\max ZB}$ [m/s]	Δs [μm]	Δs_{red} [μm]	C_{lin} [N/μm]	m_n [mm]	z	d_0 [mm]	F_{f2N} [kN]	F_{f2acc} [kN]	F_{f2NOT} [kN]	M_{2acc} [Nm]
ZR2PH4 ($F_{f2acc,max} = 4,9$ kN)															
4.000	ZR233SPH431_0040 ME	2600	5000	≤24	4.58	31	10	48	2	33	70.0	2.5	3.9	6.4	136
4.000	ZR233SPH431_0040 MEL	2600	5000	≤32	4.58	31	10	48	2	33	70.0	2.5	3.9	6.4	136
5.000	ZR233SPH431_0050 ME	3000	6000	≤24	4.40	31	10	47	2	33	70.0	2.6	4.9	6.4	172
5.000	ZR233SPH431_0050 MEL	3000	6000	≤32	4.40	31	10	47	2	33	70.0	2.6	4.9	6.4	172
7.000	ZR233SPH431_0070 ME	3200	6000	≤24	3.14	31	10	44	2	33	70.0	2.6	4.6	6.4	160
7.000	ZR233SPH431_0070 MEL	3200	6000	≤32	3.14	31	10	44	2	33	70.0	2.6	4.6	6.4	160
10.00	ZR233SPH431_0100 ME	3500	7000	≤24	2.57	31	10	36	2	33	70.0	2.1	3.3	6.4	115
10.00	ZR233SPH431_0100 MEL	3500	7000	≤32	2.57	31	10	36	2	33	70.0	2.1	3.3	6.4	115
16.00	ZR233SPH432_0160 ME	4000	8000	≤19	1.83	31	10	44	2	33	70.0	2.6	4.6	6.4	160
16.00	ZR233SPH432_0160 MEL	4000	8000	≤24	1.83	31	10	44	2	33	70.0	2.6	4.6	6.4	160
20.00	ZR233SPH432_0200 ME	4000	8000	≤19	1.47	31	10	45	2	33	70.0	2.7	4.3	6.4	150
20.00	ZR233SPH432_0200 MEL	4000	8000	≤24	1.47	31	10	45	2	33	70.0	2.7	4.3	6.4	150
25.00	ZR233SPH432_0250 ME	4500	8000	≤19	1.17	31	10	45	2	33	70.0	2.9	4.6	6.4	161
25.00	ZR233SPH432_0250 MEL	4500	8000	≤24	1.17	31	10	45	2	33	70.0	2.9	4.6	6.4	161
28.00	ZR233SPH432_0280 ME	4500	8000	≤19	1.05	31	10	45	2	33	70.0	2.7	4.6	6.4	160
28.00	ZR233SPH432_0280 MEL	4500	8000	≤24	1.05	31	10	45	2	33	70.0	2.7	4.6	6.4	160
35.00	ZR233SPH432_0350 ME	4500	8000	≤19	0.84	31	10	45	2	33	70.0	3.1	4.6	6.4	160
35.00	ZR233SPH432_0350 MEL	4500	8000	≤24	0.84	31	10	45	2	33	70.0	3.1	4.6	6.4	160
40.00	ZR233SPH432_0400 ME	4500	8000	≤19	0.73	31	10	44	2	33	70.0	3.1	4.4	6.4	155
40.00	ZR233SPH432_0400 MEL	4500	8000	≤24	0.73	31	10	44	2	33	70.0	3.1	4.4	6.4	155
50.00	ZR233SPH432_0500 ME	4500	8000	≤19	0.59	31	10	44	2	33	70.0	3.4	4.5	6.4	159
50.00	ZR233SPH432_0500 MEL	4500	8000	≤24	0.59	31	10	44	2	33	70.0	3.4	4.5	6.4	159
70.00	ZR233SPH432_0700 ME	4500	8000	≤19	0.42	31	10	42	2	33	70.0	3.4	4.5	6.4	158
70.00	ZR233SPH432_0700 MEL	4500	8000	≤24	0.42	31	10	42	2	33	70.0	3.4	4.5	6.4	158
100.0	ZR233SPH432_1000 ME	4500	8000	≤19	0.29	31	10	34	2	33	70.0	2.4	3.1	6.3	110
100.0	ZR233SPH432_1000 MEL	4500	8000	≤24	0.29	31	10	34	2	33	70.0	2.4	3.1	6.3	110
ZR2PH5 ($F_{f2acc,max} = 8,1$ kN)															
4.000	ZR240SPH531_0040 ME	2200	5000	≤32	5.56	37	12	77	2	40	84.9	3.6	8.1	10	345
4.000	ZR240SPH531_0040 MEL	2200	5000	≤38	5.56	37	12	78	2	40	84.9	3.6	8.1	10	345
5.000	ZR240SPH531_0050 ME	2500	5500	≤32	4.89	37	12	77	2	40	84.9	3.9	8.1	10	345
5.000	ZR240SPH531_0050 MEL	2500	5500	≤38	4.89	37	12	78	2	40	84.9	3.9	8.1	10	345
7.000	ZR240SPH531_0070 ME	3000	6000	≤32	3.81	37	12	71	2	40	84.9	4.4	8.1	10	345
7.000	ZR240SPH531_0070 MEL	3000	6000	≤38	3.81	37	12	71	2	40	84.9	4.4	8.1	10	345
10.00	ZR240SPH531_0100 ME	3300	6500	≤32	2.89	37	12	59	2	40	84.9	4.2	6.8	10	288
10.00	ZR240SPH531_0100 MEL	3300	6500	≤38	2.89	37	12	59	2	40	84.9	4.2	6.8	10	288
16.00	ZR240SPH532_0160 ME	3500	7000	≤24	1.94	37	12	74	2	40	84.9	5.4	8.1	10	345
16.00	ZR240SPH532_0160 MEL	3500	7000	≤32	1.94	37	12	74	2	40	84.9	5.4	8.1	10	345
20.00	ZR240SPH532_0200 ME	3500	7000	≤24	1.56	37	12	75	2	40	84.9	5.9	8.1	10	345
20.00	ZR240SPH532_0200 MEL	3500	7000	≤32	1.56	37	12	75	2	40	84.9	5.9	8.1	10	345
25.00	ZR240SPH532_0250 ME	3700	7500	≤24	1.33	37	12	75	2	40	84.9	6.1	8.1	10	345
25.00	ZR240SPH532_0250 MEL	3700	7500	≤32	1.33	37	12	75	2	40	84.9	6.1	8.1	10	345
28.00	ZR240SPH532_0280 ME	4000	8000	≤24	1.27	37	12	73	2	40	84.9	5.7	8.1	10	345
28.00	ZR240SPH532_0280 MEL	4000	8000	≤32	1.27	37	12	73	2	40	84.9	5.7	8.1	10	345
35.00	ZR240SPH532_0350 ME	4000	8000	≤24	1.02	37	12	74	2	40	84.9	6.7	8.1	10	345
35.00	ZR240SPH532_0350 MEL	4000	8000	≤32	1.02	37	12	74	2	40	84.9	6.7	8.1	10	345
40.00	ZR240SPH532_0400 ME	4000	8000	≤24	0.89	37	12	70	2	40	84.9	6.1	8.1	10	345
40.00	ZR240SPH532_0400 MEL	4000	8000	≤32	0.89	37	12	70	2	40	84.9	6.1	8.1	10	345
50.00	ZR240SPH532_0500 ME	4000	8000	≤24	0.71	37	12	73	2	40	84.9	6.7	8.1	10	345
50.00	ZR240SPH532_0500 MEL	4000	8000	≤32	0.71	37	12	73	2	40	84.9	6.7	8.1	10	345
70.00	ZR240SPH532_0700 ME	4000	8000	≤24	0.51	37	12	68	2	40	84.9	6.7	8.1	10	345
70.00	ZR240SPH532_0700 MEL	4000	8000	≤32	0.51	37	12	68	2	40	84.9	6.7	8.1	10	345

7.2 Selection tables 7 ZRPH rack and pinion drives

i	Type	n_{1maxDB}	n_{1maxZB}	d_{MW}	v_{ZmaxZB}	Δs	Δs_{red}	C_{lin}	m_n	z	d_0	F_{Z2N}	F_{Z2acc}	F_{Z2NOT}	M_{Z2acc}
		[rpm]	[rpm]	[mm]	[m/s]	[μ m]	[μ m]	[N/ μ m]	[mm]						
ZR2PH5 ($F_{Z2acc,max} = 8,1$ kN)															
100.0	ZR240SPH532_1000 ME	4000	8000	≤ 24	0.36	37	12	58	2	40	84.9	5.2	6.8	10	288
100.0	ZR240SPH532_1000 MEL	4000	8000	≤ 32	0.36	37	12	58	2	40	84.9	5.2	6.8	10	288
ZR3PH5 ($F_{Z2acc,max} = 7,7$ kN)															
4.000	ZR330SPH531_0040 ME	2200	5000	≤ 32	6.25	42	14	62	3	30	95.5	3.6	7.4	9.6	355
4.000	ZR330SPH531_0040 MEL	2200	5000	≤ 38	6.25	42	14	62	3	30	95.5	3.6	7.4	9.6	355
5.000	ZR330SPH531_0050 ME	2500	5500	≤ 32	5.50	42	14	62	3	30	95.5	3.8	7.7	9.6	368
5.000	ZR330SPH531_0050 MEL	2500	5500	≤ 38	5.50	42	14	62	3	30	95.5	3.8	7.7	9.6	368
7.000	ZR330SPH531_0070 ME	3000	6000	≤ 32	4.29	42	14	57	3	30	95.5	4.3	7.7	9.6	368
7.000	ZR330SPH531_0070 MEL	3000	6000	≤ 38	4.29	42	14	57	3	30	95.5	4.3	7.7	9.6	368
10.00	ZR330SPH531_0100 ME	3300	6500	≤ 32	3.25	42	14	47	3	30	95.5	3.8	6.0	9.6	288
10.00	ZR330SPH531_0100 MEL	3300	6500	≤ 38	3.25	42	14	47	3	30	95.5	3.8	6.0	9.6	288
16.00	ZR330SPH532_0160 ME	3500	7000	≤ 24	2.19	42	14	59	3	30	95.5	4.8	7.4	9.6	355
16.00	ZR330SPH532_0160 MEL	3500	7000	≤ 32	2.19	42	14	59	3	30	95.5	4.8	7.4	9.6	355
20.00	ZR330SPH532_0200 ME	3500	7000	≤ 24	1.75	42	14	60	3	30	95.5	5.2	7.7	9.6	368
20.00	ZR330SPH532_0200 MEL	3500	7000	≤ 32	1.75	42	14	60	3	30	95.5	5.2	7.7	9.6	368
25.00	ZR330SPH532_0250 ME	3700	7500	≤ 24	1.50	42	14	60	3	30	95.5	5.4	7.7	9.6	368
25.00	ZR330SPH532_0250 MEL	3700	7500	≤ 32	1.50	42	14	60	3	30	95.5	5.4	7.7	9.6	368
28.00	ZR330SPH532_0280 ME	4000	8000	≤ 24	1.43	42	14	58	3	30	95.5	5.0	7.4	9.6	355
28.00	ZR330SPH532_0280 MEL	4000	8000	≤ 32	1.43	42	14	58	3	30	95.5	5.0	7.4	9.6	355
35.00	ZR330SPH532_0350 ME	4000	8000	≤ 24	1.14	42	14	60	3	30	95.5	6.1	7.7	9.6	368
35.00	ZR330SPH532_0350 MEL	4000	8000	≤ 32	1.14	42	14	60	3	30	95.5	6.1	7.7	9.6	368
40.00	ZR330SPH532_0400 ME	4000	8000	≤ 24	1.00	42	14	56	3	30	95.5	5.4	7.4	9.6	355
40.00	ZR330SPH532_0400 MEL	4000	8000	≤ 32	1.00	42	14	56	3	30	95.5	5.4	7.4	9.6	355
50.00	ZR330SPH532_0500 ME	4000	8000	≤ 24	0.80	42	14	58	3	30	95.5	6.2	7.7	9.6	368
50.00	ZR330SPH532_0500 MEL	4000	8000	≤ 32	0.80	42	14	58	3	30	95.5	6.2	7.7	9.6	368
70.00	ZR330SPH532_0700 ME	4000	8000	≤ 24	0.57	42	14	55	3	30	95.5	6.0	7.7	9.6	368
70.00	ZR330SPH532_0700 MEL	4000	8000	≤ 32	0.57	42	14	55	3	30	95.5	6.0	7.7	9.6	368
100.0	ZR330SPH532_1000 ME	4000	8000	≤ 24	0.40	42	14	46	3	30	95.5	4.6	6.0	9.6	288
100.0	ZR330SPH532_1000 MEL	4000	8000	≤ 32	0.40	42	14	46	3	30	95.5	4.6	6.0	9.6	288
ZR3PH7 ($F_{Z2acc,max} = 16$ kN)															
4.000	ZR335SPH731_0040 ME	1900	4000	≤ 38	5.83	49	16	105	3	35	111.4	7.9	15	19	840
4.000	ZR335SPH731_0040 MEL	1900	4000	≤ 48	5.83	49	16	108	3	35	111.4	7.9	15	19	840
4.000	ZR340SPH731_0040 ME	1900	4000	≤ 38	6.67	56	19	93	3	40	127.3	6.9	13	17	840
4.000	ZR340SPH731_0040 MEL	1900	4000	≤ 48	6.67	56	19	95	3	40	127.3	6.9	13	17	840
5.000	ZR335SPH731_0050 ME	2200	5000	≤ 38	5.83	49	16	101	3	35	111.4	7.9	16	19	869
5.000	ZR335SPH731_0050 MEL	2200	5000	≤ 48	5.83	49	16	103	3	35	111.4	7.9	16	19	869
5.000	ZR340SPH731_0050 ME	2200	5000	≤ 38	6.67	56	19	89	3	40	127.3	6.9	14	17	879
5.000	ZR340SPH731_0050 MEL	2200	5000	≤ 48	6.67	56	19	90	3	40	127.3	6.9	14	17	879
7.000	ZR335SPH731_0070 ME	2500	5000	≤ 38	4.17	49	16	93	3	35	111.4	7.9	16	19	869
7.000	ZR335SPH731_0070 MEL	2500	5000	≤ 48	4.17	49	16	93	3	35	111.4	7.9	16	19	869
7.000	ZR340SPH731_0070 ME	2500	5000	≤ 38	4.76	56	19	80	3	40	127.3	6.9	14	17	869
7.000	ZR340SPH731_0070 MEL	2500	5000	≤ 48	4.76	56	19	81	3	40	127.3	6.9	14	17	869
10.00	ZR335SPH731_0100 ME	2500	5000	≤ 38	2.92	49	16	80	3	35	111.4	6.3	10	19	575
10.00	ZR335SPH731_0100 MEL	2500	5000	≤ 48	2.92	49	16	80	3	35	111.4	6.3	10	19	575
10.00	ZR340SPH731_0100 ME	2500	5000	≤ 38	3.33	56	19	68	3	40	127.3	5.5	9.0	17	575
10.00	ZR340SPH731_0100 MEL	2500	5000	≤ 48	3.33	56	19	68	3	40	127.3	5.5	9.0	17	575
16.00	ZR335SPH732_0160 ME	3000	6000	≤ 32	2.19	49	16	104	3	35	111.4	8.1	13	19	740
16.00	ZR335SPH732_0160 MEL	3000	6000	≤ 38	2.19	49	16	104	3	35	111.4	8.1	13	19	740
16.00	ZR340SPH732_0160 ME	3000	6000	≤ 32	2.50	56	19	91	3	40	127.3	7.1	12	17	740
16.00	ZR340SPH732_0160 MEL	3000	6000	≤ 38	2.50	56	19	91	3	40	127.3	7.1	12	17	740
20.00	ZR335SPH732_0200 ME	3000	6000	≤ 32	1.75	49	16	100	3	35	111.4	8.3	14	19	805
20.00	ZR335SPH732_0200 MEL	3000	6000	≤ 38	1.75	49	16	100	3	35	111.4	8.3	14	19	805
20.00	ZR340SPH732_0200 ME	3000	6000	≤ 32	2.00	56	19	87	3	40	127.3	7.2	13	17	805
20.00	ZR340SPH732_0200 MEL	3000	6000	≤ 38	2.00	56	19	88	3	40	127.3	7.2	13	17	805
25.00	ZR335SPH732_0250 ME	3500	7000	≤ 32	1.63	49	16	100	3	35	111.4	9.0	16	19	866
25.00	ZR335SPH732_0250 MEL	3500	7000	≤ 38	1.63	49	16	100	3	35	111.4	9.0	16	19	866
25.00	ZR340SPH732_0250 ME	3500	7000	≤ 32	1.87	56	19	87	3	40	127.3	7.9	14	17	866
25.00	ZR340SPH732_0250 MEL	3500	7000	≤ 38	1.87	56	19	87	3	40	127.3	7.9	14	17	866
28.00	ZR335SPH732_0280 ME	3700	7000	≤ 32	1.46	49	16	102	3	35	111.4	9.7	14	19	770
28.00	ZR335SPH732_0280 MEL	3700	7000	≤ 38	1.46	49	16	102	3	35	111.4	9.7	14	19	770
28.00	ZR340SPH732_0280 ME	3700	7000	≤ 32	1.67	56	19	89	3	40	127.3	8.5	12	17	770
28.00	ZR340SPH732_0280 MEL	3700	7000	≤ 38	1.67	56	19	89	3	40	127.3	8.5	12	17	770
35.00	ZR335SPH732_0350 ME	3700	7000	≤ 32	1.17	49	16	99	3	35	111.4	9.7	16	19	866
35.00	ZR335SPH732_0350 MEL	3700	7000	≤ 38	1.17	49	16	99	3	35	111.4	9.7	16	19	866
35.00	ZR340SPH732_0350 ME	3700	7000	≤ 32	1.33	56	19	87	3	40	127.3	8.5	14	17	866
35.00	ZR340SPH732_0350 MEL	3700	7000	≤ 38	1.33	56	19	87	3	40	127.3	8.5	14	17	866

i	Type	n_{1maxDB}	n_{1maxZB}	d_{MW}	$v_{f2maxZB}$	Δs	Δs_{red}	C_{lin}	m_n	z	d_0	F_{f2N}	F_{f2acc}	F_{f2NOT}	M_{2acc}
		[rpm]	[rpm]	[mm]	[m/s]	[μ m]	[μ m]	[N/ μ m]	[mm]		[mm]	[kN]	[kN]	[kN]	[Nm]
ZR3PH7 ($F_{f2acc,max} = 16$ kN)															
40.00	ZR335SPH732_0400 ME	3700	7000	≤ 32	1.02	49	16	99	3	35	111.4	9.7	14	19	770
40.00	ZR335SPH732_0400 MEL	3700	7000	≤ 38	1.02	49	16	99	3	35	111.4	9.7	14	19	770
40.00	ZR340SPH732_0400 ME	3700	7000	≤ 32	1.17	56	19	86	3	40	127.3	8.5	12	17	770
40.00	ZR340SPH732_0400 MEL	3700	7000	≤ 38	1.17	56	19	86	3	40	127.3	8.5	12	17	770
50.00	ZR335SPH732_0500 ME	3700	7000	≤ 32	0.82	49	16	97	3	35	111.4	11	15	19	830
50.00	ZR335SPH732_0500 MEL	3700	7000	≤ 38	0.82	49	16	97	3	35	111.4	11	15	19	830
50.00	ZR340SPH732_0500 ME	3700	7000	≤ 32	0.93	56	19	85	3	40	127.3	9.4	13	17	830
50.00	ZR340SPH732_0500 MEL	3700	7000	≤ 38	0.93	56	19	85	3	40	127.3	9.4	13	17	830
70.00	ZR335SPH732_0700 ME	3700	7000	≤ 32	0.58	49	16	91	3	35	111.4	11	15	19	809
70.00	ZR335SPH732_0700 MEL	3700	7000	≤ 38	0.58	49	16	91	3	35	111.4	11	15	19	809
70.00	ZR340SPH732_0700 ME	3700	7000	≤ 32	0.67	56	19	78	3	40	127.3	9.4	13	17	809
70.00	ZR340SPH732_0700 MEL	3700	7000	≤ 38	0.67	56	19	78	3	40	127.3	9.4	13	17	809
100.0	ZR335SPH732_1000 ME	3700	7000	≤ 32	0.41	49	16	79	3	35	111.4	7.6	9.9	19	550
100.0	ZR335SPH732_1000 MEL	3700	7000	≤ 38	0.41	49	16	79	3	35	111.4	7.6	9.9	19	550
100.0	ZR340SPH732_1000 ME	3700	7000	≤ 32	0.47	56	19	67	3	40	127.3	6.6	8.6	17	550
100.0	ZR340SPH732_1000 MEL	3700	7000	≤ 38	0.47	56	19	67	3	40	127.3	6.6	8.6	17	550
ZR4PH7 ($F_{f2acc,max} = 14$ kN)															
4.000	ZR430SPH731_0040 ME	1900	4000	≤ 38	6.67	56	19	91	4	30	127.3	6.9	13	17	840
4.000	ZR430SPH731_0040 MEL	1900	4000	≤ 48	6.67	56	19	93	4	30	127.3	6.9	13	17	840
5.000	ZR430SPH731_0050 ME	2200	5000	≤ 38	6.67	56	19	87	4	30	127.3	6.9	14	17	882
5.000	ZR430SPH731_0050 MEL	2200	5000	≤ 48	6.67	56	19	88	4	30	127.3	6.9	14	17	882
7.000	ZR430SPH731_0070 ME	2500	5000	≤ 38	4.76	56	19	79	4	30	127.3	6.9	14	17	869
7.000	ZR430SPH731_0070 MEL	2500	5000	≤ 48	4.76	56	19	79	4	30	127.3	6.9	14	17	869
10.00	ZR430SPH731_0100 ME	2500	5000	≤ 38	3.33	56	19	67	4	30	127.3	5.5	9.0	17	575
10.00	ZR430SPH731_0100 MEL	2500	5000	≤ 48	3.33	56	19	67	4	30	127.3	5.5	9.0	17	575
16.00	ZR430SPH732_0160 ME	3000	6000	≤ 32	2.50	56	19	89	4	30	127.3	7.1	12	17	740
16.00	ZR430SPH732_0160 MEL	3000	6000	≤ 38	2.50	56	19	89	4	30	127.3	7.1	12	17	740
20.00	ZR430SPH732_0200 ME	3000	6000	≤ 32	2.00	56	19	86	4	30	127.3	7.2	13	17	805
20.00	ZR430SPH732_0200 MEL	3000	6000	≤ 38	2.00	56	19	86	4	30	127.3	7.2	13	17	805
25.00	ZR430SPH732_0250 ME	3500	7000	≤ 32	1.87	56	19	86	4	30	127.3	7.9	14	17	866
25.00	ZR430SPH732_0250 MEL	3500	7000	≤ 38	1.87	56	19	86	4	30	127.3	7.9	14	17	866
28.00	ZR430SPH732_0280 ME	3700	7000	≤ 32	1.67	56	19	88	4	30	127.3	8.5	12	17	770
28.00	ZR430SPH732_0280 MEL	3700	7000	≤ 38	1.67	56	19	88	4	30	127.3	8.5	12	17	770
35.00	ZR430SPH732_0350 ME	3700	7000	≤ 32	1.33	56	19	85	4	30	127.3	8.5	14	17	866
35.00	ZR430SPH732_0350 MEL	3700	7000	≤ 38	1.33	56	19	85	4	30	127.3	8.5	14	17	866
40.00	ZR430SPH732_0400 ME	3700	7000	≤ 32	1.17	56	19	85	4	30	127.3	8.5	12	17	770
40.00	ZR430SPH732_0400 MEL	3700	7000	≤ 38	1.17	56	19	85	4	30	127.3	8.5	12	17	770
50.00	ZR430SPH732_0500 ME	3700	7000	≤ 32	0.93	56	19	83	4	30	127.3	9.4	13	17	830
50.00	ZR430SPH732_0500 MEL	3700	7000	≤ 38	0.93	56	19	83	4	30	127.3	9.4	13	17	830
70.00	ZR430SPH732_0700 ME	3700	7000	≤ 32	0.67	56	19	77	4	30	127.3	9.4	13	17	809
70.00	ZR430SPH732_0700 MEL	3700	7000	≤ 38	0.67	56	19	77	4	30	127.3	9.4	13	17	809
100.0	ZR430SPH732_1000 ME	3700	7000	≤ 32	0.47	56	19	66	4	30	127.3	6.6	8.6	17	550
100.0	ZR430SPH732_1000 MEL	3700	7000	≤ 38	0.47	56	19	66	4	30	127.3	6.6	8.6	17	550

7.3 Dimensional drawings

In this chapter, you can find the dimensions of the rack and pinion drives with motor adapter.

Dimension az in the tables of dimensions applies to STOBBER gear racks. In general: $az = \frac{1}{2} d_0 + h_0 + x \cdot mn$

The pinion of the rack and pinion drive is helical (left-hand $19^\circ 31' 42''$). The pinion gearing quality is 5.

Dimensions can exceed the specifications of ISO 2768-mK due to casting tolerances or accumulation of individual tolerances.

We reserve the right to make dimensional changes due to ongoing technical development.

You can download 3D models of our standard drives at <https://configurator.stoeber.de/en-US/>.

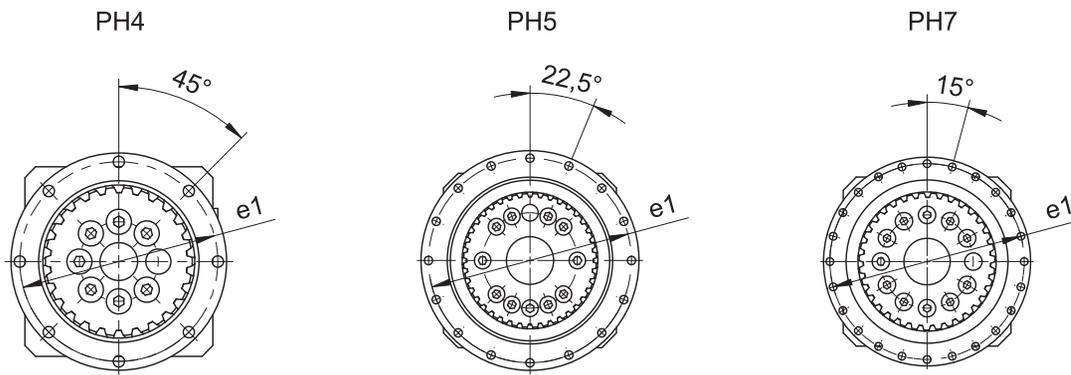
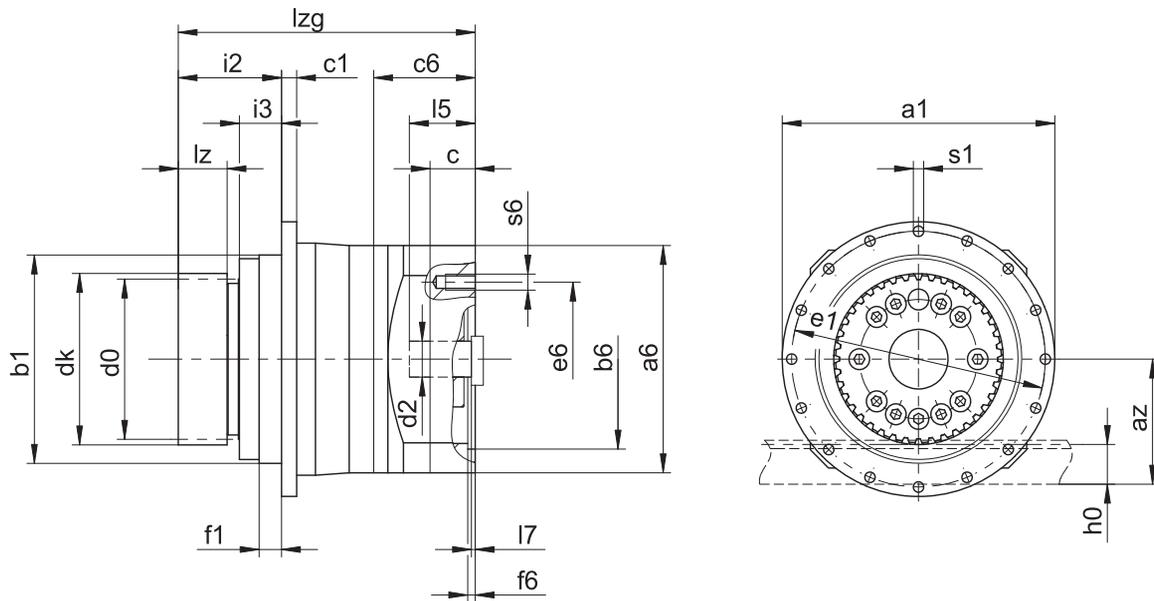

Output dimensions

Type	mn	$\varnothing a_1$	az	$\varnothing b_1$	c1	d0	dk	$\varnothing e_1$	f1	i2	h0	i3	l _z	$\varnothing s_1$	x
ZR233SPH4_	2	118	57.80	90_{h7}	7	70.03	75.0	109	10	56.0	22	23.5	26	5.5	0.39
ZR240SPH5_	2	145	65.20	110_{h7}	8	84.88	90.0	135	12	55.0	22	22.5	26	5.5	0.38
ZR330SPH5_	3	145	73.75	110_{h7}	8	95.49	101.5	135	12	64.0	26	22.5	35	5.5	0.00
ZR335SPH7_	3	179	82.80	140_{h7}	10	111.41	119.0	168	12	69.0	26	31.5	31	6.6	0.37
ZR340SPH7_	3	179	90.80	140_{h7}	10	127.32	135.0	168	12	69.0	26	31.5	31	6.6	0.38
ZR430SPH7_	4	179	98.66	140_{h7}	10	127.32	135.3	168	12	83.0	35	31.5	45	6.6	0.00

Example dimensions for the motor connection + total length

Type	Øb6	Øe6	Ød2max	l5	□a6	c	c6	f6	l7	lzg	s6
ZR233SPH431_ME	95 ^{H7}	115	24	41	100	21	42.5	4.0	3.5	139.5	M8
ZR233SPH432_ME	60 ^{H7}	75	19	41	75	18	41.5	3.5	4.0	176.5	M5
ZR240SPH531_ME	110 ^{H7}	130	32	51	120	24	54.0	4.0	4.5	158.0	M8
ZR330SPH531_ME	110 ^{H7}	130	32	51	120	24	54.0	4.0	4.5	167.0	M8
ZR240SPH532_ME	95 ^{H7}	115	24	41	100	21	42.5	4.0	3.5	187.0	M8
ZR330SPH532_ME	95 ^{H7}	115	24	41	100	21	42.5	4.0	3.5	196.0	M8
ZR335SPH731_ME	130 ^{H7}	165	38	61	150	26	66.0	5.5	4.5	192.0	M10
ZR340SPH731_ME	130 ^{H7}	165	38	61	150	26	66.0	5.5	4.5	192.0	M10
ZR430SPH731_ME	130 ^{H7}	165	38	61	150	26	66.0	5.5	4.5	206.0	M10
ZR335SPH732_ME	110 ^{H7}	130	32	51	120	24	54.0	4.0	4.5	230.0	M8
ZR340SPH732_ME	110 ^{H7}	130	32	51	120	24	54.0	4.0	4.5	230.0	M8
ZR430SPH732_ME	110 ^{H7}	130	32	51	120	24	54.0	4.0	4.5	244.0	M8

In the table above, you will find example dimensions for the motor connection for the ME motor adapter.

Note that when dimension c is lengthened, dimensions c6, l5 and lzg are also lengthened accordingly.

You will find additional motor connection dimensions for motor adapters ME, MEL and MF in our STOBBER Configurator at <https://configurator.stoeber.de/en-US/>. Here, you can directly download a 3D model of your drive.

7.4 Type designation

This chapter shows you an explanation of the type designation with the associated options.

Additional ordering information not included in the type designation can be found at the end of the chapter.

Example code

Z	R	3	30	S	PH	5	3	2	S	F	S	S	0280	ME
---	---	---	----	---	----	---	---	---	---	---	---	---	------	----

Explanation

Code	Designation	Design
Z	Type	Rack and pinion drive
R	Design	Screwed pinion
3	Normal module	$m_n = 3$ mm (example)
30	Number of teeth	$z = 30$ (example)
S	Toothing	Helical (left-hand 19° 31' 42")
PH	Type	Planetary gear unit
5	Size	5 (example)
3	Generation	Generation 3
1	Stages	Single-stage
2		Two-stage
S	Housing	Standard
F	Shaft	Flange shaft
S	Bearing	Standard bearing
V		Reinforced bearing (PH3 – PH5)
S	Backlash	Standard
R		Reduced
0280	Transmission ratio ($i \times 10$)	$i = 28$ (example)
ME	Motor adapter	Motor adapter with EasyAdapt coupling
MEL		Motor adapter with EasyAdapt coupling for large motors
MF		Motor adapter with FlexiAdapt coupling
MB ¹		ServoStop motor adapter with brake

To complete the type designation, also specify the following in your order:

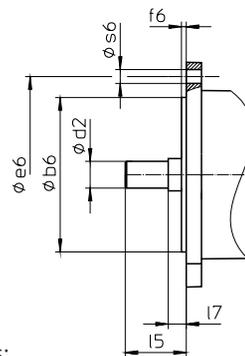

- Motor type or motor dimensions:

To choose a suitable motor connection, use the STOBER Configurator at

<https://configurator.stoeber.de/en-US/> and choose your motor or the dimensions of the motor connection.

- Radial shaft seal rings at the output made of NBR or FKM (option), see the chapter [▶ 7.6.3]
- Reverse operation of the output shaft from $\pm 20^\circ$ to $\pm 90^\circ$ for horizontal installation on request
- PH531, PH7: Double seal for motor adapter (option)
- Socket wrench insert for mounting the motor on the gear unit using the ME/MEL/MF motor adapter (option)

In this product catalog, you will find all the information about rack and pinion drives with a motor adapter. All input options available upon request are listed in the chapter [▶ 7.5.1].

7.4.1 Nameplate

An example gear unit nameplate is explained in the figure below.

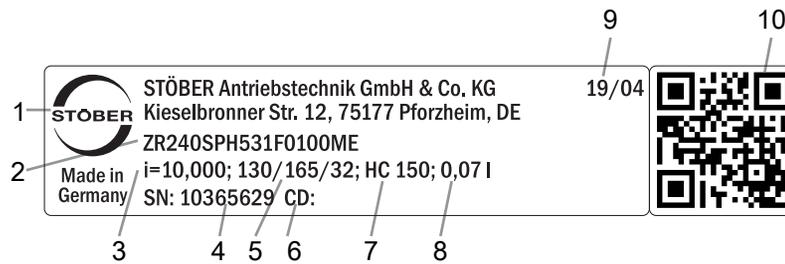

Code	Designation
1	Name of manufacturer
2	Type designation
3	Gear ratio of the gear unit
4	Serial number of the gear unit
5	Dimensions of the motor adapter (pilot/bolt circle/motor shaft diameter)
6	Customer-specific data
7	Lubricant specification
8	Lubricant fill volume
9	Date of manufacture (year/calendar week)
10	QR code (link to product information)

7.4.1.1 Supporting documents

You can view or download supporting documents for the product by reading off the serial number on the nameplate of the product and entering it at the following address online:

<https://id.stober.com>

Alternatively, you can use a suitable mobile device to scan in the QR code on the nameplate of the product in order to be linked to the supporting documents.

7.5 Product description

7.5.1 Input options

In this chapter, you will find all available input options:

Motor adapter



Catalog ID 443137_en

EZ synchronous servo motor



Catalog ID 443286_en

KX right-angle input with MF motor adapter



On request

K right-angle input with ME motor adapter



On request

MB motor adapter



On request

The corresponding catalogs can be found at <http://www.stober.de/en/downloads/>

Enter the ID of the catalog in the Search term field.

7.5.2 Motor adapter with EasyAdapt coupling (ME/MEL)

In this chapter, you will find a description of the EasyAdapt coupling.

Properties:

- Fast and easy motor attachment
- One-piece, rugged clamp coupling with expanding function
- Lowest mass moments of inertia for the highest dynamics
- Balanced for smooth running without vibration, even at high speeds
- Large selection of motor shaft diameters and lengths
- Error-free, thanks to exact centering of the motor
- For reduced backlash, the motor shaft bearing must have an axially backlash-free design



Fig. 1: EasyAdapt coupling

7.5.3 Motor adapter with FlexiAdapt coupling (MF)

In this chapter, you will find a description of the FlexiAdapt coupling.

Properties:

- Fast and easy motor attachment
- Rugged, laser-welded bellow coupling with expanding function
- With integrated thermal length compensation, compensates for linear expansion of the motor shaft
- Motor shaft decoupled from axial forces
- Balanced for smooth running without vibration, even at high speeds
- Large selection of motor shaft diameters and lengths
- Error-free, thanks to exact centering of the motor



Fig. 2: FlexiAdapt coupling

7.5.4 Gear rack

The gear rack used must have a right-hand design (19° 31' 42"); the load capacity must not be exceeded.

When using a STOBER gear rack, please also observe the project configuration in the chapter [\[▶ 13.6\]](#).

7.5.5 Installation conditions

The torque and force values listed in this catalog are valid under the following conditions:

- When the gear housing is fastened on the machine side using screws of strength class 12.9
- When the gear housings are adjusted at pilot \varnothing bz. The machine-side fit must be H7.

7.5.6 Lubricants

STOBER fills the gear units with the amount and type of lubricant specified on the nameplate.

You will receive lubricants for use in the food industry upon request.

7.5.6.1 Rack and pinion drive lubrication

Ensure permanent lubrication with the lubricants recommended in the chapter [\[▶ 13.5.1\]](#).

7.5.7 Other product features

Feature	Value
Max. permitted gear unit temperature (on the surface of the gear unit)	≤ 90 °C
Paint	Black RAL 9005
(ATEX) Directive 2014/34/EU (optional)	Not suitable.
Protection class: ²	
Planetary gear unit	IP65
Pinion/gear rack	IPXX

7.5.8 Direction of rotation

The input and output rotate in the same direction.

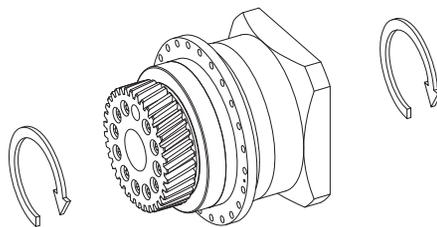

²Observe the protection class of all the components.

7.6 Project configuration

Project your drives using our SERVOfsoft designing software. Download SERVOfsoft free of charge after registration at <https://www.stoeber.de/en/services/info-servosoft/>.

It is the most convenient and reliable method of drive selection, as the entire torque/speed curve of the application is displayed and evaluated here in the curve of the geared motor.

In this chapter, only limit values for specific operating points can be taken into consideration for manual drive selection.

The formula symbols for values actually present in the application are marked with *.

An explanation of the formula symbols can be found in the chapter [▶ 14.1](#).

7.6.1 Drive selection

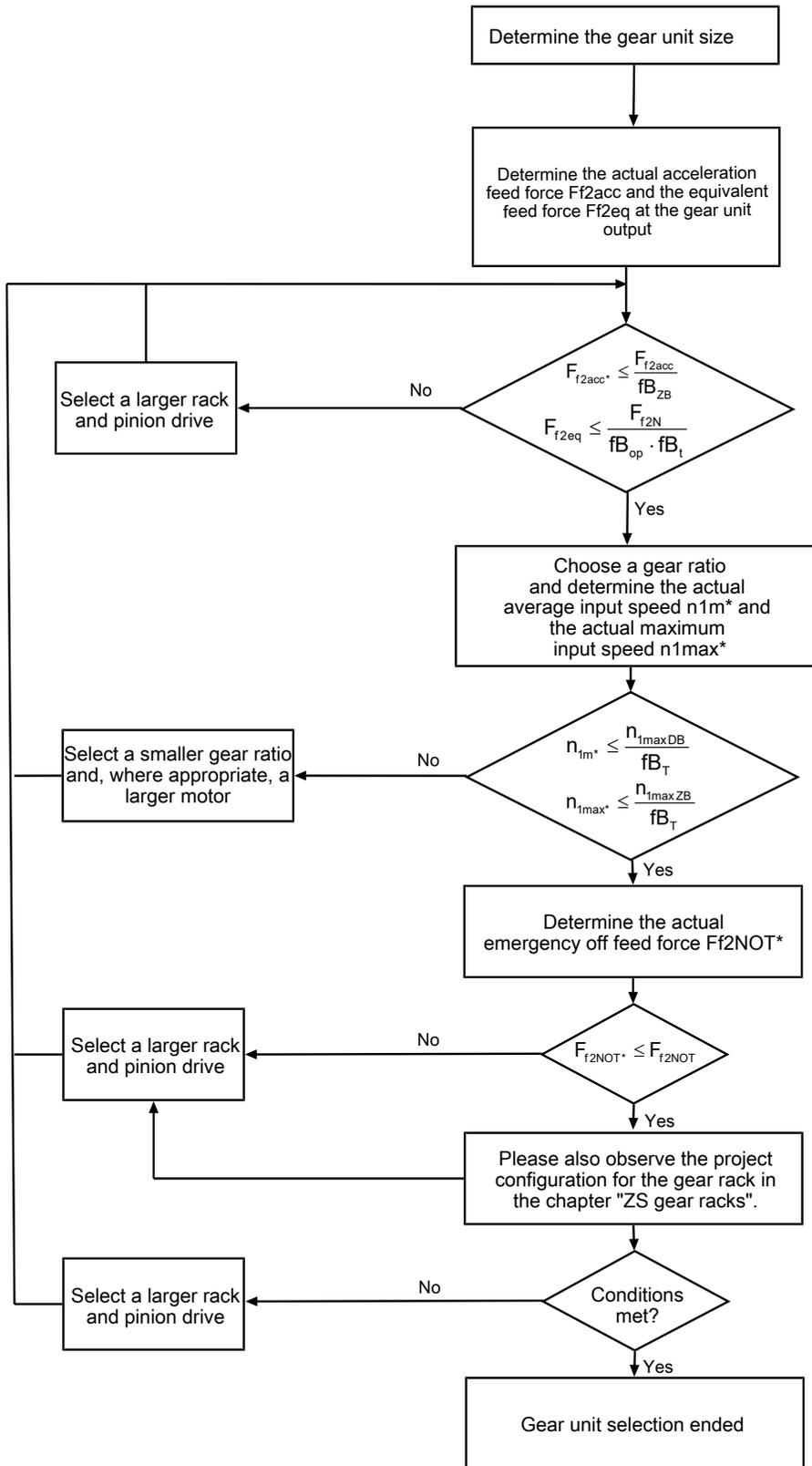

Refer to the selection tables for the values for i , n_{1maxDB} , n_{1maxZB} , F_{f2acc} , F_{f2N} and F_{f2NOT} .

The values for f_{B_T} , $f_{B_{op}}$, f_{B_t} and $f_{B_{zB}}$ can be found in the corresponding tables in this chapter.

Example of cyclic operation

The following calculations are based on a representation of the power taken from the output based in accordance with the following example:

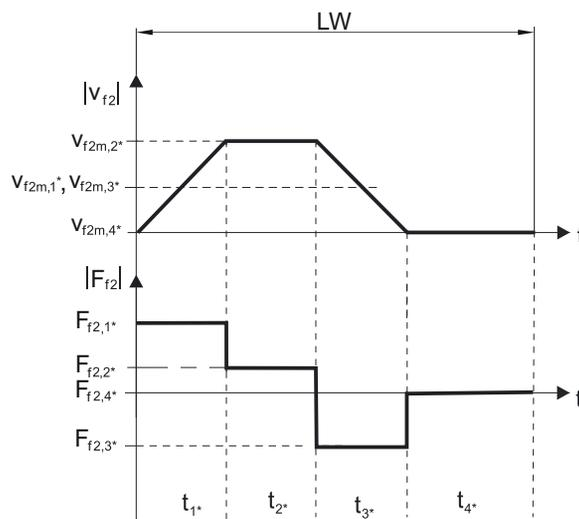

Calculation of the actual maximum acceleration feed force

$$F_{f2acc*} = m \cdot a^* + F_{L*}$$

Calculation of the actual average input speed

$$n_{1m*} = \frac{v_{f2m*} \cdot i}{d_0 \cdot \pi}$$

$$v_{f2m*} = \frac{|v_{f2m,1*}| \cdot t_{1*} + \dots + |v_{f2m,n*}| \cdot t_{n*}}{t_{1*} + \dots + t_{n*}}$$

If $t_{1*} + \dots + t_{3*} \geq 6$ min, determine v_{2m*} without the rest phase t_{4*} .

The values for the ratio i can be found in the selection tables.

Calculation of the actual emergency off feed force

$$F_{f2NOT*} = m \cdot a_{NOT*} + F_{L*}$$

Calculation of the actual equivalent feed force

$$F_{f2eq*} = \sqrt[3]{\frac{|v_{f2m,1*}| \cdot t_{1*} \cdot |F_{f2,1*}|^3 + \dots + |v_{f2m,n*}| \cdot t_{n*} \cdot |F_{f2,n*}|^3}{|v_{f2m,1*}| \cdot t_{1*} + \dots + |v_{f2m,n*}| \cdot t_{n*}}}$$

Operating factors

Operating mode	fB_{op}
Uniform continuous operation	1.00
Cyclic operation	1.00
Reversing load cyclic operation	1.00
Run time	fB_t
Daily runtime ≤ 8 h	1.00
Daily runtime ≤ 16 h	1.15
Daily runtime ≤ 24 h	1.20
Cyclic operation	fB_{ZB}
≤ 1000 load changes/hour (LW/h)	1.00
> 1000 load changes/hour (LW/h)	1.15

Temperature		f_{B_T}
Motor cooling	Surrounding temperature	
Motor with forced ventilation	$\leq 20\text{ °C}$	0.9
	$\leq 30\text{ °C}$	1.0
	$\leq 40\text{ °C}$	1.15
Motor with convection cooling	$\leq 20\text{ °C}$	1.0
	$\leq 30\text{ °C}$	1.1
	$\leq 40\text{ °C}$	1.25

Notes

- The maximum permitted gear unit temperature (see the "Other product features" chapter) must not be exceeded, as that could result in damage.
- For braking from full speed (for example, when the power fails or when setting up the machine), note the permitted gear unit feed forces (F_{f2acc} , F_{f2NOT}) in the selection tables.

7.6.2 Permitted breakdown torques at the gear unit input

For a horizontal mounting position of the motor, verify that the permitted breakdown torque at the gear unit input is not exceeded before installation on a STOBBER gear unit. You can find information for how to do that in this chapter.

Calculate the actual breakdown torque as follows:

$$M_{1k^*} = F_{1k^*} \cdot l_{sp} \leq M_{1k}$$

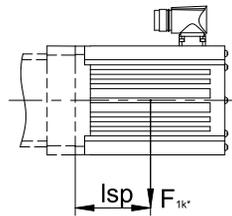

Type	M_{1k} [Nm]
PH331_ME	20
PH332_ME	10
PH431_ME	40
PH432_ME	20
PH531_ME	80
PH532_ME	40
PH731_ME	200
PH732_ME	80
PH831_ME	400
PH832_ME	200
PH942_ME	400
PH1042_ME	400

The values also apply to the MEL and MF motor adapters.

7.6.3 Recommendation for radial shaft seal rings

For a duty cycle > 60% and higher surrounding temperatures, we recommend radial shaft seal rings made of FKM at the output.

Properties:

- Excellent temperature resistance
- High chemical stability
- Very good resistance to aging
- Excellent resistance in oils and greases
- For use in the food, beverage and pharmaceutical industries

Leak-proofness

Our gear units are equipped with high-quality radial shaft seal rings and checked for leaks. However, a leak cannot be fully ruled out over the length of use of a gear unit. If you use a gear unit with goods incompatible with the lubricant, you must take measures to prevent direct contact with the gear unit lubricant in case of a leak.

7.7 Additional documentation

Additional documentation related to the product can be found at

<http://www.stoeber.de/en/downloads/>

Enter the ID of the documentation in the Search term field.

Documentation	ID
Operating manual gear units, geared motors PH33 – PH83, PH94 – PH104	443354_en
Operating manual gear racks	443392_en

8 ZVP rack and pinion drives

Table of contents

8.1	Overview	106
8.2	Selection tables	107
8.3	Dimensional drawings	111
8.3.1	Pinion position E	112
8.3.2	Pinion position S	113
8.4	Type designation	114
8.4.1	Nameplate	115
8.5	Product description	115
8.5.1	Input options	115
8.5.2	Motor adapter with EasyAdapt coupling (ME/MEL)	116
8.5.3	Motor adapter with FlexiAdapt coupling (MF)	116
8.5.4	Gear rack	116
8.5.5	Installation conditions	117
8.5.6	Lubricants	117
8.5.7	Other product features	117
8.5.8	Direction of rotation	117
8.6	Project configuration	117
8.6.1	Drive selection	118
8.6.2	Permitted breakdown torques at the gear unit input	120
8.6.3	Recommendation for radial shaft seal rings	121
8.7	Additional documentation	121

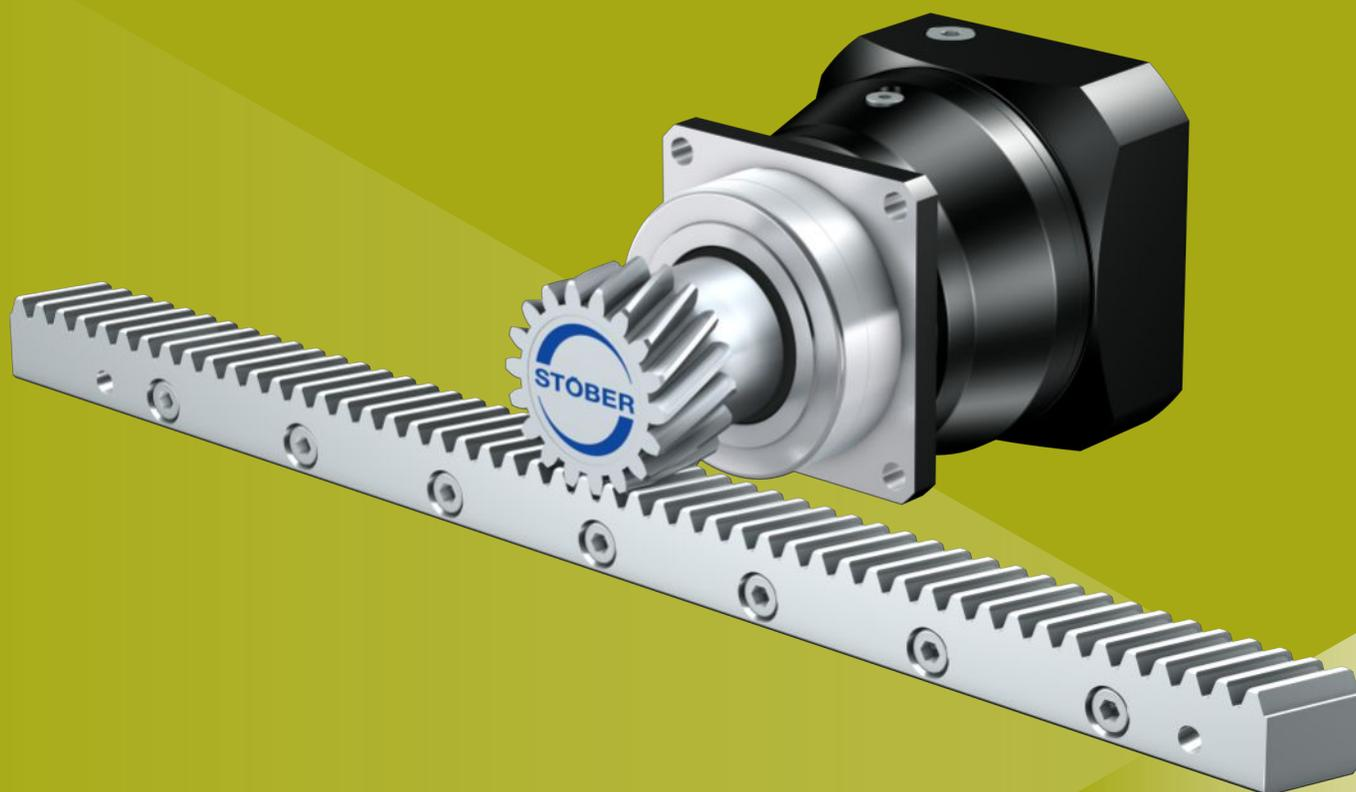

8 Rack and pinion drives

ZVP

8.1 Overview

Precision planetary gear units with plug-on pinion

Features

Power density	★★★★☆
Linear clearance	★★★★★
Price category	€€
Smooth operation	★★★★☆
Linear rigidity	★★★★☆
Mass moment of inertia	★★★★☆
Ready-to-install drive solution	✓
Pinion gearing quality 6 (DIN 3962)	✓
Helical gearing	✓
Case-hardened and smoothed	✓

Key ★☆☆☆☆ good | ★★★★★ excellent

€ Economy | €€€€€ Premium

Technical data

m_n	2 – 4 mm
z	16 – 25
F_{f2acc}	1.7 – 15 kN
$v_{f2maxZB}$	0.14 – 5.3 m/s
Δs	8 – 44 μm

8.2 Selection tables

The technical data specified in the selection tables applies to:

- Pinion position E with bearing design S (standard)
- Pinion position S with bearing design D (axially reinforced, option)
- De-energized installation
- Permanent lubrication with the lubricants recommended in the chapter on gear racks [▶ 13.5.1]
- Case-hardened pinions, helical (left-hand 19° 31' 42"), gearing quality 6
- Installation altitudes up to 1000 m above sea level
- Surrounding temperatures from 0 °C to 40 °C
- Without consideration of the thermal limiting performance
- C_{lin} : Pinion position S with bearing design D (axially reinforced, option)

Higher feed forces are possible for rack and pinion drives with reduced backlash, reinforced bearing D (axially reinforced) or pinion position S. You can find this and all other technical data, as well as other combinations of the pinion position and bearing design, at <https://configurator.stoeber.de/en-US/>.

An explanation of the formula symbols can be found in the chapter [▶ 14.1].

i	Type	n_{1maxDB} [rpm]	n_{1maxZB} [rpm]	d_{MW} [mm]	v_{ZmaxZB} [m/s]	Δs [μm]	Δs_{red} [μm]	C_{lin} [N/ μm]	m_n [mm]	z	d_0 [mm]	$F_{ZN,S}$ [kN]	$F_{ZN,E}$ [kN]	F_{ZaccS} [kN]	F_{ZaccE} [kN]	$F_{ZNOT,S}$ [kN]	$F_{ZNOT,E}$ [kN]	M_{ZaccS} [Nm]	M_{ZaccE} [Nm]
ZV2P3 ($F_{Zacc,max} = 2,0$ kN)																			
3.000	ZV216S_P331_0030 ME	3500	7000	≤19	4.15	20	10	16	2	16	34.0	1.8	1.5	2.0	1.7	4.0	3.3	34	28
3.000	ZV216S_P331_0030 MEL	3500	7000	≤24	4.15	20	10	16	2	16	34.0	1.8	1.5	2.0	1.7	4.0	3.3	34	28
4.000	ZV216S_P331_0040 ME	4000	8000	≤19	3.56	20	10	16	2	16	34.0	2.0	1.6	2.0	1.7	4.0	3.3	34	28
4.000	ZV216S_P331_0040 MEL	4000	8000	≤24	3.56	20	10	16	2	16	34.0	2.0	1.6	2.0	1.7	4.0	3.3	34	28
5.000	ZV216S_P331_0050 ME	4500	8000	≤19	2.84	20	10	16	2	16	34.0	2.0	1.7	2.0	1.7	4.0	3.3	34	28
5.000	ZV216S_P331_0050 MEL	4500	8000	≤24	2.84	20	10	16	2	16	34.0	2.0	1.7	2.0	1.7	4.0	3.3	34	28
7.000	ZV216S_P331_0070 ME	5000	8000	≤19	2.03	20	10	16	2	16	34.0	2.0	1.7	2.0	1.7	4.0	3.3	34	28
7.000	ZV216S_P331_0070 MEL	5000	8000	≤24	2.03	20	10	16	2	16	34.0	2.0	1.7	2.0	1.7	4.0	3.3	34	28
8.000	ZV216S_P331_0080 ME	5000	8000	≤19	1.78	20	10	15	2	16	34.0	2.0	1.7	2.0	1.7	4.0	3.3	34	28
8.000	ZV216S_P331_0080 MEL	5000	8000	≤24	1.78	20	10	15	2	16	34.0	2.0	1.7	2.0	1.7	4.0	3.3	34	28
10.00	ZV216S_P331_0100 ME	5500	8000	≤19	1.42	20	10	15	2	16	34.0	2.0	1.7	2.0	1.7	4.0	3.3	34	28
10.00	ZV216S_P331_0100 MEL	5500	8000	≤24	1.42	20	10	15	2	16	34.0	2.0	1.7	2.0	1.7	4.0	3.3	34	28
12.00	ZV216S_P332_0120 ME	5500	8000	≤14	1.19	25	15	15	2	16	34.0	1.8	1.7	2.0	1.7	4.0	3.3	34	28
12.00	ZV216S_P332_0120 MEL	5500	8000	≤19	1.19	25	15	15	2	16	34.0	1.8	1.7	2.0	1.7	4.0	3.3	34	28
16.00	ZV216S_P332_0160 ME	5500	8000	≤14	0.89	25	15	16	2	16	34.0	2.0	1.7	2.0	1.7	4.0	3.3	34	28
16.00	ZV216S_P332_0160 MEL	5500	8000	≤19	0.89	25	15	16	2	16	34.0	2.0	1.7	2.0	1.7	4.0	3.3	34	28
20.00	ZV216S_P332_0200 ME	5500	8000	≤14	0.71	25	15	16	2	16	34.0	2.0	1.7	2.0	1.7	4.0	3.3	34	28
20.00	ZV216S_P332_0200 MEL	5500	8000	≤19	0.71	25	15	16	2	16	34.0	2.0	1.7	2.0	1.7	4.0	3.3	34	28
25.00	ZV216S_P332_0250 ME	6000	8000	≤14	0.57	25	15	16	2	16	34.0	2.0	1.7	2.0	1.7	4.0	3.3	34	28
25.00	ZV216S_P332_0250 MEL	6000	8000	≤19	0.57	25	15	16	2	16	34.0	2.0	1.7	2.0	1.7	4.0	3.3	34	28
28.00	ZV216S_P332_0280 ME	6000	8000	≤14	0.51	25	15	16	2	16	34.0	2.0	1.7	2.0	1.7	4.0	3.3	34	28
28.00	ZV216S_P332_0280 MEL	6000	8000	≤19	0.51	25	15	16	2	16	34.0	2.0	1.7	2.0	1.7	4.0	3.3	34	28
32.00	ZV216S_P332_0320 ME	5500	8000	≤14	0.44	25	15	15	2	16	34.0	2.0	1.7	2.0	1.7	4.0	3.3	34	28
32.00	ZV216S_P332_0320 MEL	5500	8000	≤19	0.44	25	15	15	2	16	34.0	2.0	1.7	2.0	1.7	4.0	3.3	34	28
35.00	ZV216S_P332_0350 ME	6000	8000	≤14	0.41	25	15	16	2	16	34.0	2.0	1.7	2.0	1.7	4.0	3.3	34	28
35.00	ZV216S_P332_0350 MEL	6000	8000	≤19	0.41	25	15	16	2	16	34.0	2.0	1.7	2.0	1.7	4.0	3.3	34	28
40.00	ZV216S_P332_0400 ME	6000	8000	≤14	0.36	25	15	15	2	16	34.0	2.0	1.7	2.0	1.7	4.0	3.3	34	28
40.00	ZV216S_P332_0400 MEL	6000	8000	≤19	0.36	25	15	15	2	16	34.0	2.0	1.7	2.0	1.7	4.0	3.3	34	28
50.00	ZV216S_P332_0500 ME	6000	8000	≤14	0.28	25	15	16	2	16	34.0	2.0	1.7	2.0	1.7	4.0	3.3	34	28
50.00	ZV216S_P332_0500 MEL	6000	8000	≤19	0.28	25	15	16	2	16	34.0	2.0	1.7	2.0	1.7	4.0	3.3	34	28
56.00	ZV216S_P332_0560 ME	6000	8000	≤14	0.25	25	15	15	2	16	34.0	2.0	1.7	2.0	1.7	4.0	3.3	34	28
56.00	ZV216S_P332_0560 MEL	6000	8000	≤19	0.25	25	15	15	2	16	34.0	2.0	1.7	2.0	1.7	4.0	3.3	34	28
70.00	ZV216S_P332_0700 ME	6000	8000	≤14	0.20	25	15	16	2	16	34.0	2.0	1.7	2.0	1.7	4.0	3.3	34	28
70.00	ZV216S_P332_0700 MEL	6000	8000	≤19	0.20	25	15	16	2	16	34.0	2.0	1.7	2.0	1.7	4.0	3.3	34	28
80.00	ZV216S_P332_0800 ME	6000	8000	≤14	0.18	25	15	15	2	16	34.0	2.0	1.7	2.0	1.7	4.0	3.3	34	28
80.00	ZV216S_P332_0800 MEL	6000	8000	≤19	0.18	25	15	15	2	16	34.0	2.0	1.7	2.0	1.7	4.0	3.3	34	28
100.0	ZV216S_P332_1000 ME	6000	8000	≤14	0.14	25	15	15	2	16	34.0	2.0	1.7	2.0	1.7	4.0	3.3	34	28
100.0	ZV216S_P332_1000 MEL	6000	8000	≤19	0.14	25	15	15	2	16	34.0	2.0	1.7	2.0	1.7	4.0	3.3	34	28
ZV2P4 ($F_{Zacc,max} = 4,8$ kN)																			
3.000	ZV220S_P431_0030 ME	3000	6000	≤24	4.44	25	12	25	2	20	42.4	2.4	2.2	4.7	3.2	9.4	6.3	100	67
3.000	ZV220S_P431_0030 MEL	3000	6000	≤32	4.44	25	12	25	2	20	42.4	2.4	2.2	4.7	3.2	9.4	6.3	100	67
4.000	ZV220S_P431_0040 ME	3300	6500	≤24	3.61	25	12	26	2	20	42.4	3.8	2.4	4.8	3.2	9.7	6.3	102	67
4.000	ZV220S_P431_0040 MEL	3300	6500	≤32	3.61	25	12	26	2	20	42.4	3.8	2.4	4.8	3.2	9.7	6.3	102	67
5.000	ZV220S_P431_0050 ME	3700	7000	≤24	3.11	25	12	26	2	20	42.4	4.1	2.6	4.8	3.2	9.7	6.3	102	67

8.2 Selection tables 8 ZVP rack and pinion drives

i	Type	n _{1maxDB} [rpm]	n _{1maxZB} [rpm]	d _{MW} [mm]	v _{12maxZB} [m/s]	Δs	Δs _{red} [μm]	C _{lin} [N/ μm]	m _n [mm]	z	d ₀ [mm]	F _{12N,S} [kN]	F _{12N,E} [kN]	F _{12accS} [kN]	F _{12accE} [kN]	F _{12NOT,S} [kN]	F _{12NOT,E} [kN]	M _{2accS} [Nm]	M _{2accE} [Nm]
ZV2P4 (F_{12acc,max} = 4,8 kN)																			
5.000	ZV220S_P431_0050 MEL	3700	7000	≤32	3.11	25	12	26	2	20	42.4	4.1	2.6	4.8	3.2	9.7	6.3	102	67
7.000	ZV220S_P431_0070 ME	4000	8000	≤24	2.54	25	12	25	2	20	42.4	4.2	2.9	4.8	3.2	9.7	6.3	102	67
7.000	ZV220S_P431_0070 MEL	4000	8000	≤32	2.54	25	12	25	2	20	42.4	4.2	2.9	4.8	3.2	9.7	6.3	102	67
8.000	ZV220S_P431_0080 ME	4000	8000	≤24	2.22	25	12	24	2	20	42.4	3.8	3.1	4.8	3.2	9.7	6.3	102	67
8.000	ZV220S_P431_0080 MEL	4000	8000	≤32	2.22	25	12	24	2	20	42.4	3.8	3.1	4.8	3.2	9.7	6.3	102	67
10.00	ZV220S_P431_0100 ME	4000	8000	≤24	1.78	25	12	23	2	20	42.4	3.5	3.2	4.8	3.2	9.7	6.3	102	67
10.00	ZV220S_P431_0100 MEL	4000	8000	≤32	1.78	25	12	23	2	20	42.4	3.5	3.2	4.8	3.2	9.7	6.3	102	67
12.00	ZV220S_P432_0120 ME	3500	7000	≤19	1.30	31	19	25	2	20	42.4	2.8	2.8	4.7	3.2	9.4	6.3	100	67
12.00	ZV220S_P432_0120 MEL	3500	7000	≤24	1.30	31	19	25	2	20	42.4	2.8	2.8	4.7	3.2	9.4	6.3	100	67
16.00	ZV220S_P432_0160 ME	4000	8000	≤19	1.11	31	19	25	2	20	42.4	4.2	3.2	4.8	3.2	9.7	6.3	102	67
16.00	ZV220S_P432_0160 MEL	4000	8000	≤24	1.11	31	19	25	2	20	42.4	4.2	3.2	4.8	3.2	9.7	6.3	102	67
20.00	ZV220S_P432_0200 ME	4000	8000	≤19	0.89	31	19	25	2	20	42.4	4.5	3.2	4.8	3.2	9.7	6.3	102	67
20.00	ZV220S_P432_0200 MEL	4000	8000	≤24	0.89	31	19	25	2	20	42.4	4.5	3.2	4.8	3.2	9.7	6.3	102	67
25.00	ZV220S_P432_0250 ME	4500	8000	≤19	0.71	31	19	25	2	20	42.4	4.7	3.2	4.8	3.2	9.7	6.3	102	67
25.00	ZV220S_P432_0250 MEL	4500	8000	≤24	0.71	31	19	25	2	20	42.4	4.7	3.2	4.8	3.2	9.7	6.3	102	67
28.00	ZV220S_P432_0280 ME	4500	8000	≤19	0.64	31	19	25	2	20	42.4	4.5	3.2	4.8	3.2	9.7	6.3	102	67
28.00	ZV220S_P432_0280 MEL	4500	8000	≤24	0.64	31	19	25	2	20	42.4	4.5	3.2	4.8	3.2	9.7	6.3	102	67
32.00	ZV220S_P432_0320 ME	4000	8000	≤19	0.56	31	19	24	2	20	42.4	4.2	3.2	4.8	3.2	9.7	6.3	102	67
32.00	ZV220S_P432_0320 MEL	4000	8000	≤24	0.56	31	19	24	2	20	42.4	4.2	3.2	4.8	3.2	9.7	6.3	102	67
35.00	ZV220S_P432_0350 ME	4500	8000	≤19	0.51	31	19	25	2	20	42.4	4.8	3.2	4.8	3.2	9.7	6.3	102	67
35.00	ZV220S_P432_0350 MEL	4500	8000	≤24	0.51	31	19	25	2	20	42.4	4.8	3.2	4.8	3.2	9.7	6.3	102	67
40.00	ZV220S_P432_0400 ME	5000	8000	≤19	0.44	31	19	25	2	20	42.4	4.1	3.2	4.8	3.2	9.7	6.3	102	67
40.00	ZV220S_P432_0400 MEL	5000	8000	≤24	0.44	31	19	25	2	20	42.4	4.1	3.2	4.8	3.2	9.7	6.3	102	67
50.00	ZV220S_P432_0500 ME	5000	8000	≤19	0.36	31	19	25	2	20	42.4	4.8	3.2	4.8	3.2	9.7	6.3	102	67
50.00	ZV220S_P432_0500 MEL	5000	8000	≤24	0.36	31	19	25	2	20	42.4	4.8	3.2	4.8	3.2	9.7	6.3	102	67
56.00	ZV220S_P432_0560 ME	5000	8000	≤19	0.32	31	19	24	2	20	42.4	4.2	3.2	4.8	3.2	9.7	6.3	102	67
56.00	ZV220S_P432_0560 MEL	5000	8000	≤24	0.32	31	19	24	2	20	42.4	4.2	3.2	4.8	3.2	9.7	6.3	102	67
70.00	ZV220S_P432_0700 ME	5000	8000	≤19	0.25	31	19	25	2	20	42.4	4.6	3.2	4.8	3.2	9.7	6.3	102	67
70.00	ZV220S_P432_0700 MEL	5000	8000	≤24	0.25	31	19	25	2	20	42.4	4.6	3.2	4.8	3.2	9.7	6.3	102	67
80.00	ZV220S_P432_0800 ME	5000	8000	≤19	0.22	31	19	24	2	20	42.4	4.2	3.2	4.8	3.2	9.7	6.3	102	67
80.00	ZV220S_P432_0800 MEL	5000	8000	≤24	0.22	31	19	24	2	20	42.4	4.2	3.2	4.8	3.2	9.7	6.3	102	67
100.0	ZV220S_P432_1000 ME	5000	8000	≤19	0.18	31	19	23	2	20	42.4	4.0	3.2	4.8	3.2	9.7	6.3	102	67
100.0	ZV220S_P432_1000 MEL	5000	8000	≤24	0.18	31	19	23	2	20	42.4	4.0	3.2	4.8	3.2	9.7	6.3	102	67
ZV2P5 (F_{12acc,max} = 9,5 kN)																			
3.000	ZV225S_P531_0030 ME	2500	5000	≤32	4.63	23	8	36	2	25	53.1	4.5	2.7	7.5	5.1	15	10	200	135
3.000	ZV225S_P531_0030 MEL	2500	5000	≤38	4.63	23	8	36	2	25	53.1	4.5	2.7	7.5	5.1	15	10	200	135
4.000	ZV225S_P531_0040 ME	3000	6000	≤32	4.17	23	8	37	2	25	53.1	5.9	3.0	9.5	5.1	19	10	253	135
4.000	ZV225S_P531_0040 MEL	3000	6000	≤38	4.17	23	8	37	2	25	53.1	5.9	3.0	9.5	5.1	19	10	253	135
5.000	ZV225S_P531_0050 ME	3500	7000	≤32	3.89	23	8	37	2	25	53.1	6.4	3.2	9.5	5.1	19	10	253	135
5.000	ZV225S_P531_0050 MEL	3500	7000	≤38	3.89	23	8	37	2	25	53.1	6.4	3.2	9.5	5.1	19	10	253	135
7.000	ZV225S_P531_0070 ME	3700	7000	≤32	2.78	23	8	36	2	25	53.1	7.2	3.6	9.5	5.1	19	10	253	135
7.000	ZV225S_P531_0070 MEL	3700	7000	≤38	2.78	23	8	36	2	25	53.1	7.2	3.6	9.5	5.1	19	10	253	135
8.000	ZV225S_P531_0080 ME	3700	7000	≤32	2.43	23	8	34	2	25	53.1	7.5	3.8	9.5	5.1	19	10	253	135
8.000	ZV225S_P531_0080 MEL	3700	7000	≤38	2.43	23	8	34	2	25	53.1	7.5	3.8	9.5	5.1	19	10	253	135
10.00	ZV225S_P531_0100 ME	3700	7000	≤32	1.94	23	8	34	2	25	53.1	6.8	4.1	9.5	5.1	19	10	253	135
10.00	ZV225S_P531_0100 MEL	3700	7000	≤38	1.94	23	8	34	2	25	53.1	6.8	4.1	9.5	5.1	19	10	253	135
12.00	ZV225S_P532_0120 ME	3000	6000	≤24	1.39	31	15	36	2	25	53.1	4.5	4.3	7.5	5.1	15	10	200	135
12.00	ZV225S_P532_0120 MEL	3000	6000	≤32	1.39	31	15	36	2	25	53.1	4.5	4.3	7.5	5.1	15	10	200	135
16.00	ZV225S_P532_0160 ME	3500	7000	≤24	1.22	31	15	36	2	25	53.1	8.3	4.8	9.5	5.1	19	10	253	135
16.00	ZV225S_P532_0160 MEL	3500	7000	≤32	1.22	31	15	36	2	25	53.1	8.3	4.8	9.5	5.1	19	10	253	135
20.00	ZV225S_P532_0200 ME	3500	7000	≤24	0.97	31	15	36	2	25	53.1	9.4	5.1	9.5	5.1	19	10	253	135
20.00	ZV225S_P532_0200 MEL	3500	7000	≤32	0.97	31	15	36	2	25	53.1	9.4	5.1	9.5	5.1	19	10	253	135
25.00	ZV225S_P532_0250 ME	3700	7000	≤24	0.78	31	15	36	2	25	53.1	9.5	5.1	9.5	5.1	19	10	253	135
25.00	ZV225S_P532_0250 MEL	3700	7000	≤32	0.78	31	15	36	2	25	53.1	9.5	5.1	9.5	5.1	19	10	253	135
28.00	ZV225S_P532_0280 ME	4000	8000	≤24	0.79	31	15	36	2	25	53.1	8.7	5.1	9.5	5.1	19	10	253	135
28.00	ZV225S_P532_0280 MEL	4000	8000	≤32	0.79	31	15	36	2	25	53.1	8.7	5.1	9.5	5.1	19	10	253	135
32.00	ZV225S_P532_0320 ME	3500	7000	≤24	0.61	31	15	34	2	25	53.1	9.0	5.1	9.5	5.1	19	10	253	135
32.00	ZV225S_P532_0320 MEL	3500	7000	≤32	0.61	31	15	34	2	25	53.1	9.0	5.1	9.5	5.1	19	10	253	135
35.00	ZV225S_P532_0350 ME	4000	8000	≤24	0.64	31	15	36	2	25	53.1	9.5	5.1	9.5	5.1	19	10	253	135
35.00	ZV225S_P532_0350 MEL	4000	8000	≤32	0.64	31	15	36	2	25	53.1	9.5	5.1	9.5	5.1	19	10	253	135
40.00	ZV225S_P532_0400 ME	4000	8000	≤24	0.56	31	15	36	2	25	53.1	8.1	5.1	9.5	5.1	19	10	253	135
40.00	ZV225S_P532_0400 MEL	4000	8000	≤32	0.56	31	15	36	2	25	53.1	8.1	5.1	9.5	5.1	19	10	253	135
50.00	ZV225S_P532_0500 ME	4000	8000	≤24	0.44	31	15	36	2	25	53.1	9.5	5.1	9.5	5.1	19	10	253	135
50.00	ZV225S_P532_0500 MEL	4000	8000	≤32	0.44	31	15	36	2	25	53.1	9.5	5.1	9.5	5.1	19	10	253	135
56.00	ZV225S_P532_0560 ME	4000	8000	≤24	0.40	31	15	34	2	25	53.1	8.3	5.1	9.5	5.1	19	10	253	135

i	Type	n _{1maxDB} [rpm]	n _{1maxZB} [rpm]	d _{MW} [mm]	v _{2maxZB} [m/s]	Δs [μm]	Δs _{red} [μm]	C _{lin} [N/ μm]	m _n [mm]	z	d ₀ [mm]	F _{2N,S} [kN]	F _{2N,E} [kN]	F _{2accS} [kN]	F _{2accE} [kN]	F _{2NOT,S} [kN]	F _{2NOT,E} [kN]	M _{2accS} [Nm]	M _{2accE} [Nm]
ZV2P5 (F_{2acc,max} = 9,5 kN)																			
56.00	ZV225S_P532_0560 MEL	4000	8000	≤32	0.40	31	15	34	2	25	53.1	8.3	5.1	9.5	5.1	19	10	253	135
70.00	ZV225S_P532_0700 ME	4200	8000	≤24	0.32	31	15	36	2	25	53.1	9.5	5.1	9.5	5.1	19	10	253	135
70.00	ZV225S_P532_0700 MEL	4200	8000	≤32	0.32	31	15	36	2	25	53.1	9.5	5.1	9.5	5.1	19	10	253	135
80.00	ZV225S_P532_0800 ME	4200	8000	≤24	0.28	31	15	34	2	25	53.1	8.3	5.1	9.5	5.1	19	10	253	135
80.00	ZV225S_P532_0800 MEL	4200	8000	≤32	0.28	31	15	34	2	25	53.1	8.3	5.1	9.5	5.1	19	10	253	135
100.00	ZV225S_P532_1000 ME	4200	8000	≤24	0.22	31	15	34	2	25	53.1	8.3	5.1	9.5	5.1	19	10	253	135
100.00	ZV225S_P532_1000 MEL	4200	8000	≤32	0.22	31	15	34	2	25	53.1	8.3	5.1	9.5	5.1	19	10	253	135
ZV3P5 (F_{2acc,max} = 11 kN)																			
3.000	ZV318S_P531_0030 ME	2500	5000	≤32	5.00	25	8	38	3	18	57.3	4.2	2.8	7.0	5.2	14	10	200	150
3.000	ZV318S_P531_0030 MEL	2500	5000	≤38	5.00	25	8	38	3	18	57.3	4.2	2.8	7.0	5.2	14	10	200	150
4.000	ZV318S_P531_0040 ME	3000	6000	≤32	4.50	25	8	38	3	18	57.3	5.8	3.1	10	5.2	21	10	300	150
4.000	ZV318S_P531_0040 MEL	3000	6000	≤38	4.50	25	8	38	3	18	57.3	5.8	3.1	10	5.2	21	10	300	150
5.000	ZV318S_P531_0050 ME	3500	7000	≤32	4.20	25	8	38	3	18	57.3	6.3	3.3	11	5.2	21	10	302	150
5.000	ZV318S_P531_0050 MEL	3500	7000	≤38	4.20	25	8	38	3	18	57.3	6.3	3.3	11	5.2	21	10	302	150
7.000	ZV318S_P531_0070 ME	3700	7000	≤32	3.00	25	8	37	3	18	57.3	7.0	3.7	11	5.2	21	10	302	150
7.000	ZV318S_P531_0070 MEL	3700	7000	≤38	3.00	25	8	37	3	18	57.3	7.0	3.7	11	5.2	21	10	302	150
8.000	ZV318S_P531_0080 ME	3700	7000	≤32	2.63	25	8	34	3	18	57.3	7.0	3.8	10	5.2	21	10	296	150
8.000	ZV318S_P531_0080 MEL	3700	7000	≤38	2.63	25	8	34	3	18	57.3	7.0	3.8	10	5.2	21	10	296	150
10.00	ZV318S_P531_0100 ME	3700	7000	≤32	2.10	25	8	35	3	18	57.3	6.3	4.1	10	5.2	20	10	288	150
10.00	ZV318S_P531_0100 MEL	3700	7000	≤38	2.10	25	8	35	3	18	57.3	6.3	4.1	10	5.2	20	10	288	150
12.00	ZV318S_P532_0120 ME	3000	6000	≤34	1.50	33	17	37	3	18	57.3	4.2	4.2	7.0	5.2	14	10	200	150
12.00	ZV318S_P532_0120 MEL	3000	6000	≤32	1.50	33	17	37	3	18	57.3	4.2	4.2	7.0	5.2	14	10	200	150
16.00	ZV318S_P532_0160 ME	3500	7000	≤24	1.31	33	17	38	3	18	57.3	7.7	4.8	10	5.2	21	10	300	150
16.00	ZV318S_P532_0160 MEL	3500	7000	≤32	1.31	33	17	38	3	18	57.3	7.7	4.8	10	5.2	21	10	300	150
20.00	ZV318S_P532_0200 ME	3500	7000	≤24	1.05	33	17	38	3	18	57.3	8.7	5.2	11	5.2	21	10	302	150
20.00	ZV318S_P532_0200 MEL	3500	7000	≤32	1.05	33	17	38	3	18	57.3	8.7	5.2	11	5.2	21	10	302	150
25.00	ZV318S_P532_0250 ME	3700	7000	≤24	0.84	33	17	38	3	18	57.3	9.1	5.2	11	5.2	21	10	302	150
25.00	ZV318S_P532_0250 MEL	3700	7000	≤32	0.84	33	17	38	3	18	57.3	9.1	5.2	11	5.2	21	10	302	150
28.00	ZV318S_P532_0280 ME	4000	8000	≤24	0.86	33	17	37	3	18	57.3	8.1	5.2	10	5.2	21	10	300	150
28.00	ZV318S_P532_0280 MEL	4000	8000	≤32	0.86	33	17	37	3	18	57.3	8.1	5.2	10	5.2	21	10	300	150
32.00	ZV318S_P532_0320 ME	3500	7000	≤24	0.66	33	17	35	3	18	57.3	8.4	5.2	11	5.2	21	10	302	150
32.00	ZV318S_P532_0320 MEL	3500	7000	≤32	0.66	33	17	35	3	18	57.3	8.4	5.2	11	5.2	21	10	302	150
35.00	ZV318S_P532_0350 ME	4000	8000	≤24	0.69	33	17	38	3	18	57.3	9.4	5.2	11	5.2	21	10	302	150
35.00	ZV318S_P532_0350 MEL	4000	8000	≤32	0.69	33	17	38	3	18	57.3	9.4	5.2	11	5.2	21	10	302	150
40.00	ZV318S_P532_0400 ME	4000	8000	≤24	0.60	33	17	37	3	18	57.3	7.5	5.2	10	5.2	21	10	300	150
40.00	ZV318S_P532_0400 MEL	4000	8000	≤32	0.60	33	17	37	3	18	57.3	7.5	5.2	10	5.2	21	10	300	150
50.00	ZV318S_P532_0500 ME	4000	8000	≤24	0.48	33	17	37	3	18	57.3	9.4	5.2	11	5.2	21	10	302	150
50.00	ZV318S_P532_0500 MEL	4000	8000	≤32	0.48	33	17	37	3	18	57.3	9.4	5.2	11	5.2	21	10	302	150
56.00	ZV318S_P532_0560 ME	4000	8000	≤24	0.43	33	17	35	3	18	57.3	7.7	5.2	10	5.2	20	10	288	150
56.00	ZV318S_P532_0560 MEL	4000	8000	≤32	0.43	33	17	35	3	18	57.3	7.7	5.2	10	5.2	20	10	288	150
70.00	ZV318S_P532_0700 ME	4200	8000	≤24	0.34	33	17	37	3	18	57.3	9.2	5.2	11	5.2	21	10	302	150
70.00	ZV318S_P532_0700 MEL	4200	8000	≤32	0.34	33	17	37	3	18	57.3	9.2	5.2	11	5.2	21	10	302	150
80.00	ZV318S_P532_0800 ME	4200	8000	≤24	0.30	33	17	35	3	18	57.3	7.7	5.2	10	5.2	20	10	288	150
80.00	ZV318S_P532_0800 MEL	4200	8000	≤32	0.30	33	17	35	3	18	57.3	7.7	5.2	10	5.2	20	10	288	150
100.00	ZV318S_P532_1000 ME	4200	8000	≤24	0.24	33	17	35	3	18	57.3	7.7	5.2	10	5.2	20	10	288	150
100.00	ZV318S_P532_1000 MEL	4200	8000	≤32	0.24	33	17	35	3	18	57.3	7.7	5.2	10	5.2	20	10	288	150
ZV3P7 (F_{2acc,max} = 16 kN)																			
3.000	ZV322S_P731_0030 ME	2200	4000	≤38	4.89	31	10	46	3	22	70.0	6.2	3.7	14	7.0	29	14	500	245
3.000	ZV322S_P731_0030 MEL	2200	4000	≤48	4.89	31	10	46	3	22	70.0	6.2	3.7	14	7.0	29	14	500	245
4.000	ZV322S_P731_0040 ME	2500	5000	≤38	4.58	31	10	46	3	22	70.0	6.8	4.1	16	7.0	33	14	574	245
4.000	ZV322S_P731_0040 MEL	2500	5000	≤48	4.58	31	10	46	3	22	70.0	6.8	4.1	16	7.0	33	14	574	245
5.000	ZV322S_P731_0050 ME	2700	5500	≤38	4.03	31	10	46	3	22	70.0	7.3	4.4	16	7.0	33	14	574	245
5.000	ZV322S_P731_0050 MEL	2700	5500	≤48	4.03	31	10	46	3	22	70.0	7.3	4.4	16	7.0	33	14	574	245
7.000	ZV322S_P731_0070 ME	3000	6000	≤38	3.14	31	10	45	3	22	70.0	8.2	4.9	16	7.0	33	14	574	245
7.000	ZV322S_P731_0070 MEL	3000	6000	≤48	3.14	31	10	45	3	22	70.0	8.2	4.9	16	7.0	33	14	574	245
8.000	ZV322S_P731_0080 ME	3000	6000	≤38	2.75	31	10	45	3	22	70.0	8.6	5.2	16	7.0	33	14	574	245
8.000	ZV322S_P731_0080 MEL	3000	6000	≤48	2.75	31	10	45	3	22	70.0	8.6	5.2	16	7.0	33	14	574	245
10.00	ZV322S_P731_0100 ME	3000	6000	≤38	2.20	31	10	44	3	22	70.0	9.3	5.6	16	7.0	33	14	574	245
10.00	ZV322S_P731_0100 MEL	3000	6000	≤48	2.20	31	10	44	3	22	70.0	9.3	5.6	16	7.0	33	14	574	245
12.00	ZV322S_P732_0120 ME	2500	5000	≤32	1.53	41	20	45	3	22	70.0	8.4	5.9	14	7.0	29	14	500	245
12.00	ZV322S_P732_0120 MEL	2500	5000	≤38	1.53	41	20	45	3	22	70.0	8.4	5.9	14	7.0	29	14	500	245
16.00	ZV322S_P732_0160 ME	3000	6000	≤32	1.38	41	20	46	3	22	70.0	11	6.5	16	7.0	33	14	574	245
16.00	ZV322S_P732_0160 MEL	3000	6000	≤38	1.38	41	20	46	3	22	70.0	11	6.5	16	7.0	33	14	574	245
20.00	ZV322S_P732_0200 ME	3000	6000	≤32	1.10	41	20	46	3	22	70.0	12	7.0	16	7.0	33	14	574	245
20.00	ZV322S_P732_0200 MEL	3000	6000	≤38	1.10	41	20	46	3	22	70.0	12	7.0	16	7.0	33	14	574	245

8.2 Selection tables 8 ZVP rack and pinion drives

i	Type	n _{1maxDB} [rpm]	n _{1maxZB} [rpm]	d _{MW} [mm]	v _{12maxZB} [m/s]	Δs [μm]	Δs _{red} [μm]	C _{lin} [N/ μm]	m _n [mm]	z	d ₀ [mm]	F _{12N,S} [kN]	F _{12N,E} [kN]	F _{12accS} [kN]	F _{12accE} [kN]	F _{12NOT,S} [kN]	F _{12NOT,E} [kN]	M _{2accS} [Nm]	M _{2accE} [Nm]
ZV3P7 (F_{12acc,max} = 16 kN)																			
25.00	ZV322S_P732_0250 ME	3500	7000	≤32	1.03	41	20	46	3	22	70.0	13	7.0	16	7.0	33	14	574	245
25.00	ZV322S_P732_0250 MEL	3500	7000	≤38	1.03	41	20	46	3	22	70.0	13	7.0	16	7.0	33	14	574	245
28.00	ZV322S_P732_0280 ME	3700	7000	≤32	0.92	41	20	46	3	22	70.0	13	7.0	16	7.0	33	14	574	245
28.00	ZV322S_P732_0280 MEL	3700	7000	≤38	0.92	41	20	46	3	22	70.0	13	7.0	16	7.0	33	14	574	245
32.00	ZV322S_P732_0320 ME	3000	6000	≤32	0.69	41	20	45	3	22	70.0	13	7.0	16	7.0	33	14	574	245
32.00	ZV322S_P732_0320 MEL	3000	6000	≤38	0.69	41	20	45	3	22	70.0	13	7.0	16	7.0	33	14	574	245
35.00	ZV322S_P732_0350 ME	3700	7000	≤32	0.73	41	20	46	3	22	70.0	13	7.0	16	7.0	33	14	574	245
35.00	ZV322S_P732_0350 MEL	3700	7000	≤38	0.73	41	20	46	3	22	70.0	13	7.0	16	7.0	33	14	574	245
40.00	ZV322S_P732_0400 ME	3700	7000	≤32	0.64	41	20	46	3	22	70.0	13	7.0	16	7.0	33	14	574	245
40.00	ZV322S_P732_0400 MEL	3700	7000	≤38	0.64	41	20	46	3	22	70.0	13	7.0	16	7.0	33	14	574	245
50.00	ZV322S_P732_0500 ME	3700	7000	≤32	0.51	41	20	46	3	22	70.0	13	7.0	16	7.0	33	14	574	245
50.00	ZV322S_P732_0500 MEL	3700	7000	≤38	0.51	41	20	46	3	22	70.0	13	7.0	16	7.0	33	14	574	245
56.00	ZV322S_P732_0560 ME	3700	7000	≤32	0.46	41	20	45	3	22	70.0	13	7.0	16	7.0	33	14	574	245
56.00	ZV322S_P732_0560 MEL	3700	7000	≤38	0.46	41	20	45	3	22	70.0	13	7.0	16	7.0	33	14	574	245
70.00	ZV322S_P732_0700 ME	3700	7000	≤32	0.37	41	20	45	3	22	70.0	13	7.0	16	7.0	33	14	574	245
70.00	ZV322S_P732_0700 MEL	3700	7000	≤38	0.37	41	20	45	3	22	70.0	13	7.0	16	7.0	33	14	574	245
80.00	ZV322S_P732_0800 ME	3700	7000	≤32	0.32	41	20	45	3	22	70.0	13	7.0	16	7.0	33	14	574	245
80.00	ZV322S_P732_0800 MEL	3700	7000	≤38	0.32	41	20	45	3	22	70.0	13	7.0	16	7.0	33	14	574	245
100.0	ZV322S_P732_1000 ME	3700	7000	≤32	0.26	41	20	44	3	22	70.0	12	7.0	16	7.0	31	14	550	245
100.0	ZV322S_P732_1000 MEL	3700	7000	≤38	0.26	41	20	44	3	22	70.0	12	7.0	16	7.0	31	14	550	245
ZV4P7 (F_{12acc,max} = 15 kN)																			
3.000	ZV418S_P731_0030 ME	2200	4000	≤38	5.33	33	11	48	4	18	76.4	6.0	3.8	13	7.3	26	15	500	280
3.000	ZV418S_P731_0030 MEL	2200	4000	≤48	5.33	33	11	49	4	18	76.4	6.0	3.8	13	7.3	26	15	500	280
4.000	ZV418S_P731_0040 ME	2500	5000	≤38	5.00	33	11	49	4	18	76.4	6.6	4.2	15	7.3	31	15	589	280
4.000	ZV418S_P731_0040 MEL	2500	5000	≤48	5.00	33	11	49	4	18	76.4	6.6	4.2	15	7.3	31	15	589	280
5.000	ZV418S_P731_0050 ME	2700	5500	≤38	4.40	33	11	49	4	18	76.4	7.1	4.5	15	7.3	31	15	589	280
5.000	ZV418S_P731_0050 MEL	2700	5500	≤48	4.40	33	11	49	4	18	76.4	7.1	4.5	15	7.3	31	15	589	280
7.000	ZV418S_P731_0070 ME	3000	6000	≤38	3.43	33	11	48	4	18	76.4	8.0	5.1	15	7.3	31	15	589	280
7.000	ZV418S_P731_0070 MEL	3000	6000	≤48	3.43	33	11	48	4	18	76.4	8.0	5.1	15	7.3	31	15	589	280
8.000	ZV418S_P731_0080 ME	3000	6000	≤38	3.00	33	11	47	4	18	76.4	8.3	5.3	15	7.3	31	15	589	280
8.000	ZV418S_P731_0080 MEL	3000	6000	≤48	3.00	33	11	47	4	18	76.4	8.3	5.3	15	7.3	31	15	589	280
10.00	ZV418S_P731_0100 ME	3000	6000	≤38	2.40	33	11	46	4	18	76.4	9.0	5.7	15	7.3	30	15	575	280
10.00	ZV418S_P731_0100 MEL	3000	6000	≤48	2.40	33	11	46	4	18	76.4	9.0	5.7	15	7.3	30	15	575	280
12.00	ZV418S_P732_0120 ME	2500	5000	≤32	1.67	44	22	48	4	18	76.4	7.7	6.0	13	7.3	26	15	500	280
12.00	ZV418S_P732_0120 MEL	2500	5000	≤38	1.67	44	22	48	4	18	76.4	7.7	6.0	13	7.3	26	15	500	280
16.00	ZV418S_P732_0160 ME	3000	6000	≤32	1.50	44	22	49	4	18	76.4	11	6.7	15	7.3	31	15	589	280
16.00	ZV418S_P732_0160 MEL	3000	6000	≤38	1.50	44	22	49	4	18	76.4	11	6.7	15	7.3	31	15	589	280
20.00	ZV418S_P732_0200 ME	3000	6000	≤32	1.20	44	22	49	4	18	76.4	11	7.2	15	7.3	31	15	589	280
20.00	ZV418S_P732_0200 MEL	3000	6000	≤38	1.20	44	22	49	4	18	76.4	11	7.2	15	7.3	31	15	589	280
25.00	ZV418S_P732_0250 ME	3500	7000	≤32	1.12	44	22	49	4	18	76.4	12	7.3	15	7.3	31	15	589	280
25.00	ZV418S_P732_0250 MEL	3500	7000	≤38	1.12	44	22	49	4	18	76.4	12	7.3	15	7.3	31	15	589	280
28.00	ZV418S_P732_0280 ME	3700	7000	≤32	1.00	44	22	49	4	18	76.4	12	7.3	15	7.3	31	15	589	280
28.00	ZV418S_P732_0280 MEL	3700	7000	≤38	1.00	44	22	49	4	18	76.4	12	7.3	15	7.3	31	15	589	280
32.00	ZV418S_P732_0320 ME	3000	6000	≤32	0.75	44	22	47	4	18	76.4	12	7.3	15	7.3	31	15	589	280
32.00	ZV418S_P732_0320 MEL	3000	6000	≤38	0.75	44	22	47	4	18	76.4	12	7.3	15	7.3	31	15	589	280
35.00	ZV418S_P732_0350 ME	3700	7000	≤32	0.80	44	22	49	4	18	76.4	12	7.3	15	7.3	31	15	589	280
35.00	ZV418S_P732_0350 MEL	3700	7000	≤38	0.80	44	22	49	4	18	76.4	12	7.3	15	7.3	31	15	589	280
40.00	ZV418S_P732_0400 ME	3700	7000	≤32	0.70	44	22	48	4	18	76.4	12	7.3	15	7.3	31	15	589	280
40.00	ZV418S_P732_0400 MEL	3700	7000	≤38	0.70	44	22	48	4	18	76.4	12	7.3	15	7.3	31	15	589	280
50.00	ZV418S_P732_0500 ME	3700	7000	≤32	0.56	44	22	49	4	18	76.4	12	7.3	15	7.3	31	15	589	280
50.00	ZV418S_P732_0500 MEL	3700	7000	≤38	0.56	44	22	49	4	18	76.4	12	7.3	15	7.3	31	15	589	280
56.00	ZV418S_P732_0560 ME	3700	7000	≤32	0.50	44	22	47	4	18	76.4	12	7.3	15	7.3	31	15	589	280
56.00	ZV418S_P732_0560 MEL	3700	7000	≤38	0.50	44	22	47	4	18	76.4	12	7.3	15	7.3	31	15	589	280
70.00	ZV418S_P732_0700 ME	3700	7000	≤32	0.40	44	22	48	4	18	76.4	12	7.3	15	7.3	31	15	589	280
70.00	ZV418S_P732_0700 MEL	3700	7000	≤38	0.40	44	22	48	4	18	76.4	12	7.3	15	7.3	31	15	589	280
80.00	ZV418S_P732_0800 ME	3700	7000	≤32	0.35	44	22	47	4	18	76.4	12	7.3	15	7.3	31	15	589	280
80.00	ZV418S_P732_0800 MEL	3700	7000	≤38	0.35	44	22	47	4	18	76.4	12	7.3	15	7.3	31	15	589	280
100.0	ZV418S_P732_1000 ME	3700	7000	≤32	0.28	44	22	46	4	18	76.4	11	7.3	14	7.3	29	15	550	280
100.0	ZV418S_P732_1000 MEL	3700	7000	≤38	0.28	44	22	46	4	18	76.4	11	7.3	14	7.3	29	15	550	280

8.3 Dimensional drawings

In this chapter, you can find the dimensions of the rack and pinion drives with motor adapter.

Dimension a_z in the tables of dimensions applies to STOBBER gear racks. In general: $a_z = \frac{1}{2} d_0 + h_0 + x \cdot m_n$

The pinion of the rack and pinion drive is helical (left-hand $19^\circ 31' 42''$). The pinion gearing quality is 6.

Dimensions can exceed the specifications of ISO 2768-mK due to casting tolerances or accumulation of individual tolerances.

We reserve the right to make dimensional changes due to ongoing technical development.

You can download 3D models of our standard drives at <https://configurator.stoeber.de/en-US/>.

8.3.1 Pinion position E

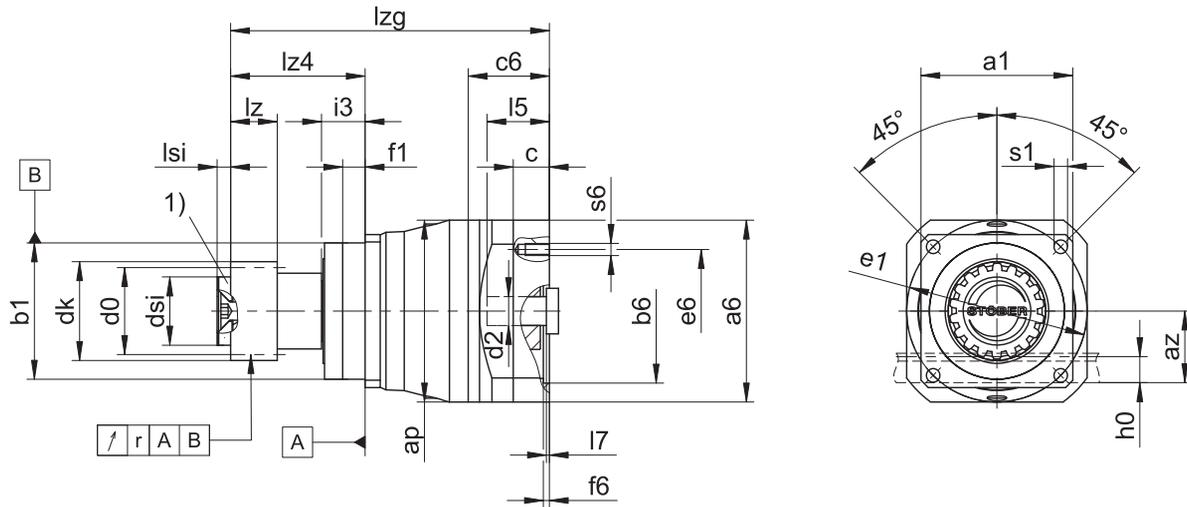

1) Axial locking (optional)

- The radial runout specification applies only to the reinforced bearing D.

Output dimensions

Type	mn	□a1	ap	az	Øb1	Ød0	Ødk	Ødsi	Øe1	f1	h0	i3	lz	lz4	lsi	r	Øs1	x
ZV216SEP331_	2	72	72	39.98	60 _{h6}	33.95	39.81	25	75	7.5	22	19	26	49.5	4	0.025	5.5	0.5
ZV216SEP332_	2	72	75	39.98	60 _{h6}	33.95	39.81	25	75	7.5	22	19	26	49.5	4	0.025	5.5	0.5
ZV220SEP431_	2	76	98	44.02	70 _{h6}	42.44	47.90	30	85	7.5	22	19	26	57.5	6	0.025	6.6	0.4
ZV220SEP432_	2	76	100	44.02	70 _{h6}	42.44	47.90	30	85	7.5	22	19	26	57.5	6	0.025	6.6	0.4
ZV225SEP531_	2	101	115	49.33	90 _{h6}	53.05	58.52	45	120	15.0	22	29	26	89.5	8	0.030	9.0	0.4
ZV225SEP532_	2	101	120	49.33	90 _{h6}	53.05	58.52	45	120	15.0	22	29	26	89.5	8	0.030	9.0	0.4
ZV318SEP531_	3	101	115	55.55	90 _{h6}	57.30	65.01	45	120	15.0	26	29	31	89.5	8	0.030	9.0	0.3
ZV318SEP532_	3	101	120	55.55	90 _{h6}	57.30	65.01	45	120	15.0	26	29	31	89.5	8	0.030	9.0	0.3
ZV322SEP731_	3	144	150	62.21	130 _{h6}	70.03	78.35	55	165	3.5	26	29	31	113.5	10	0.035	11.0	0.4
ZV322SEP732_	3	144	150	62.21	130 _{h6}	70.03	78.35	55	165	3.5	26	29	31	113.5	10	0.035	11.0	0.4
ZV418SEP731_	4	144	150	74.40	130 _{h6}	76.40	86.77	55	165	3.5	35	29	41	113.5	10	0.035	11.0	0.3
ZV418SEP732_	4	144	150	74.40	130 _{h6}	76.40	86.77	55	165	3.5	35	29	41	113.5	10	0.035	11.0	0.3

Example dimensions for the motor connection + total length

Type	Øb6	Øe6	Ød2max	l5	□a6	c	c6	f6	l7	lzg	s6
ZV_P331_ME	60 ^{H7}	75	19	41	75	18	41.5	3.5	4.0	147.0	M5
ZV_P332_ME	40 ^{H7}	63	14	30	55	15	32.0	3.5	3.0	164.5	M5
ZV_P431_ME	95 ^{H7}	115	24	41	100	21	42.5	4.0	3.5	167.0	M8
ZV_P432_ME	60 ^{H7}	75	19	41	75	18	41.5	3.5	4.0	204.0	M5
ZV_P531_ME	110 ^{H7}	130	32	51	120	24	54.0	4.0	4.5	212.0	M8
ZV_P532_ME	95 ^{H7}	115	24	41	100	21	42.5	4.0	3.5	241.0	M8
ZV_P731_ME	130 ^{H7}	165	38	61	150	26	66.0	5.5	4.5	266.0	M10
ZV_P732_ME	110 ^{H7}	130	32	51	120	24	54.0	4.0	4.5	304.0	M8

In the table above, you will find example dimensions for the motor connection for the ME motor adapter.

Note that when dimension c is lengthened, dimensions c6, l5 and lzg are also lengthened accordingly.

You will find additional motor connection dimensions for motor adapters ME, MEL and MF in our STOEBER Configurator at <https://configurator.stoeber.de/en-US/>. Here, you can directly download a 3D model of your drive.

8.3.2 Pinion position S

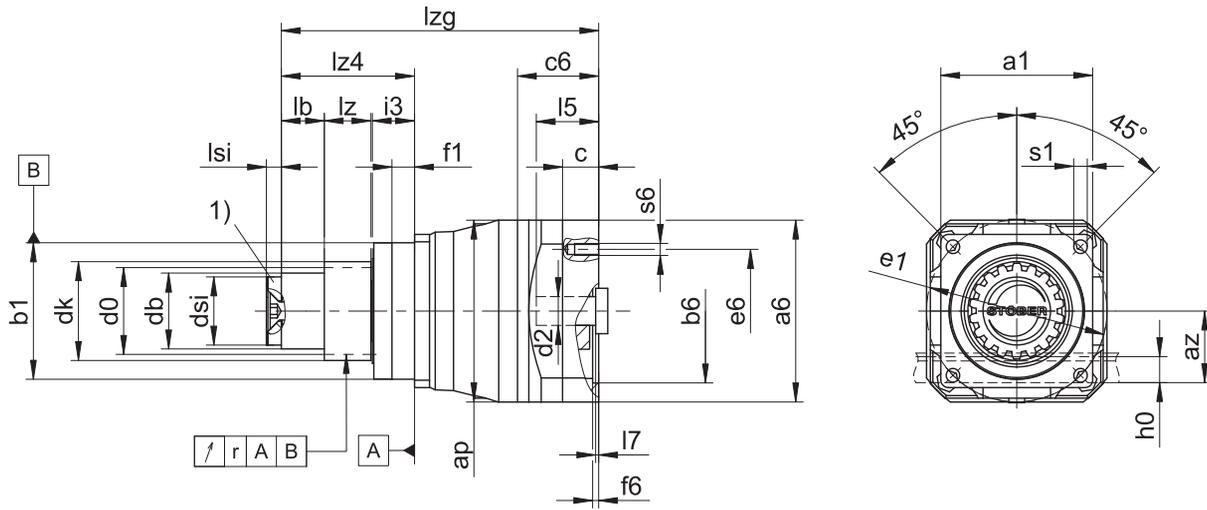

1) Axial locking (optional)

- The radial runout specification applies only to the reinforced bearing D.

Output dimensions

Type	mn	□a1	ap	az	Øb1	Ød0	Ødb	Ødk	Ødsi	Øe1	f1	h0	i3	lb	lz	lz4	lsi	r	Øs1	x
ZV216SSP331_	2	72	72	39.98	60 _{h6}	34.0	30	39.81	25	75	7.5	22	18	4.5	26	49.5	4	0.025	5.5	0.5
ZV216SSP332_	2	72	75	39.98	60 _{h6}	34.0	30	39.81	25	75	7.5	22	18	4.5	26	49.5	4	0.025	5.5	0.5
ZV220SSP431_	2	76	98	44.02	70 _{h6}	42.4	38	47.90	30	85	7.5	22	18	12.5	26	57.5	6	0.025	6.6	0.4
ZV220SSP432_	2	76	100	44.02	70 _{h6}	42.4	38	47.90	30	85	7.5	22	18	12.5	26	57.5	6	0.025	6.6	0.4
ZV225SSP531_	2	101	115	49.33	90 _{h6}	53.1	50	58.52	45	120	15.0	22	28	34.5	26	89.5	8	0.030	9.0	0.4
ZV225SSP532_	2	101	120	49.33	90 _{h6}	53.1	50	58.52	45	120	15.0	22	28	34.5	26	89.5	8	0.030	9.0	0.4
ZV318SSP531_	3	101	115	55.55	90 _{h6}	57.3	50	65.01	45	120	15.0	26	28	29.5	31	89.5	8	0.030	9.0	0.3
ZV318SSP532_	3	101	120	55.55	90 _{h6}	57.3	50	65.01	45	120	15.0	26	28	29.5	31	89.5	8	0.030	9.0	0.3
ZV322SSP731_	3	144	150	62.21	130 _{h6}	70.0	62	78.35	55	165	3.5	26	28	53.5	31	113.5	10	0.035	11.0	0.4
ZV322SSP732_	3	144	150	62.21	130 _{h6}	70.0	62	78.35	55	165	3.5	26	28	53.5	31	113.5	10	0.035	11.0	0.4
ZV418SSP731_	4	144	150	74.40	130 _{h6}	76.4	62	86.77	55	165	3.5	35	28	43.5	41	113.5	10	0.035	11.0	0.3
ZV418SSP732_	4	144	150	74.40	130 _{h6}	76.4	62	86.77	55	165	3.5	35	28	43.5	41	113.5	10	0.035	11.0	0.3

Example dimensions for the motor connection + total length

Type	Øb6	Øe6	Ød2max	l5	□a6	c	c6	f6	l7	lzg	s6
ZV_P331_ME	60 ^{H7}	75	19	41	75	18	41.5	3.5	4.0	147.0	M5
ZV_P332_ME	40 ^{H7}	63	14	30	55	15	32.0	3.5	3.0	164.5	M5
ZV_P431_ME	95 ^{H7}	115	24	41	100	21	42.5	4.0	3.5	167.0	M8
ZV_P432_ME	60 ^{H7}	75	19	41	75	18	41.5	3.5	4.0	204.0	M5
ZV_P531_ME	110 ^{H7}	130	32	51	120	24	54.0	4.0	4.5	212.0	M8
ZV_P532_ME	95 ^{H7}	115	24	41	100	21	42.5	4.0	3.5	241.0	M8
ZV_P731_ME	130 ^{H7}	165	38	61	150	26	66.0	5.5	4.5	266.0	M10
ZV_P732_ME	110 ^{H7}	130	32	51	120	24	54.0	4.0	4.5	304.0	M8

In the table above, you will find example dimensions for the motor connection for the ME motor adapter.

Note that when dimension c is lengthened, dimensions c6, l5 and lzg are also lengthened accordingly.

You will find additional motor connection dimensions for motor adapters ME, MEL and MF in our STOEBER Configurator at <https://configurator.stoeber.de/en-US/>. Here, you can directly download a 3D model of your drive.

8.4 Type designation

This chapter shows you an explanation of the type designation with the associated options.

Additional ordering information not included in the type designation can be found at the end of the chapter.

Example code

Z	V	3	22	S	S	P	7	3	1	S	P	S	S	0050	ME
---	---	---	----	---	---	---	---	---	---	---	---	---	---	------	----

Explanation

Code	Designation	Design
Z	Type	Rack and pinion drive
V	Design	Plug-on pinion
3	Normal module	$m_n = 3$ mm (example)
22	Number of teeth	$z = 22$ (example)
S	Toothing	Helical (left-hand 19° 31' 42")
E	Pinion position	Shaft end
S		Shaft shoulder
P	Type	Planetary gear unit
7	Size	7 (example)
3	Generation	Generation 3
1	Stages	Single-stage
2		Two-stage
S	Housing	Standard
P	Shaft	Solid shaft with feather key
S	Bearing	Standard bearing
D		Axially reinforced bearing
S	Backlash	Standard
R		Reduced
0050	Transmission ratio ($i \times 10$)	$i = 5$ (example)
ME	Motor adapter	Motor adapter with EasyAdapt coupling
MEL		Motor adapter with EasyAdapt coupling for large motors
MF		Motor adapter with FlexiAdapt coupling
MB ¹		ServoStop motor adapter with brake

To complete the type designation, also specify the following in your order:

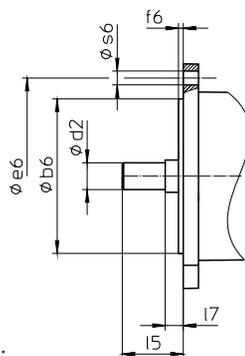

- Motor type or motor dimensions:

To choose a suitable motor connection, use the STOBER Configurator at

<https://configurator.stoeber.de/en-US/> and choose your motor or the dimensions of the motor connection.

- Radial shaft seal rings at the output made of NBR or FKM (option), see the chapter [▶ 8.6.3]
- For axial locking (optional), see the chapter [▶ 8.3]
- Reverse operation of the output shaft from $\pm 20^\circ$ to $\pm 90^\circ$ for horizontal installation on request
- P531, P7: Double seal for motor adapter (option)
- Socket wrench insert for mounting the motor on the gear unit using the ME/MEL/MF motor adapter (option)

In this product catalog, you will find all the information about rack and pinion drives with a motor adapter. All input options available upon request are listed in the chapter [▶ 8.5.1].

8.4.1 Nameplate

An example gear unit nameplate is explained in the figure below.

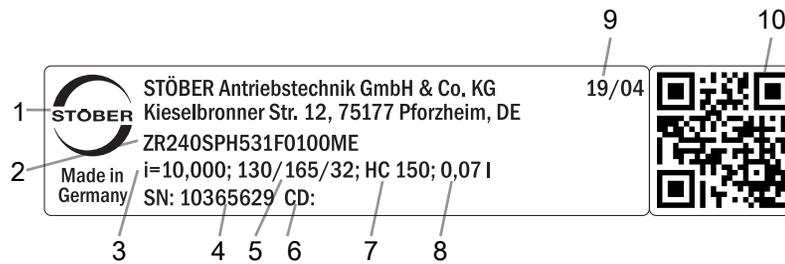

Code	Designation
1	Name of manufacturer
2	Type designation
3	Gear ratio of the gear unit
4	Serial number of the gear unit
5	Dimensions of the motor adapter (pilot/bolt circle/motor shaft diameter)
6	Customer-specific data
7	Lubricant specification
8	Lubricant fill volume
9	Date of manufacture (year/calendar week)
10	QR code (link to product information)

8.4.1.1 Supporting documents

You can view or download supporting documents for the product by reading off the serial number on the nameplate of the product and entering it at the following address online:

<https://id.stober.com>

Alternatively, you can use a suitable mobile device to scan in the QR code on the nameplate of the product in order to be linked to the supporting documents.

8.5 Product description

8.5.1 Input options

In this chapter, you will find all available input options:

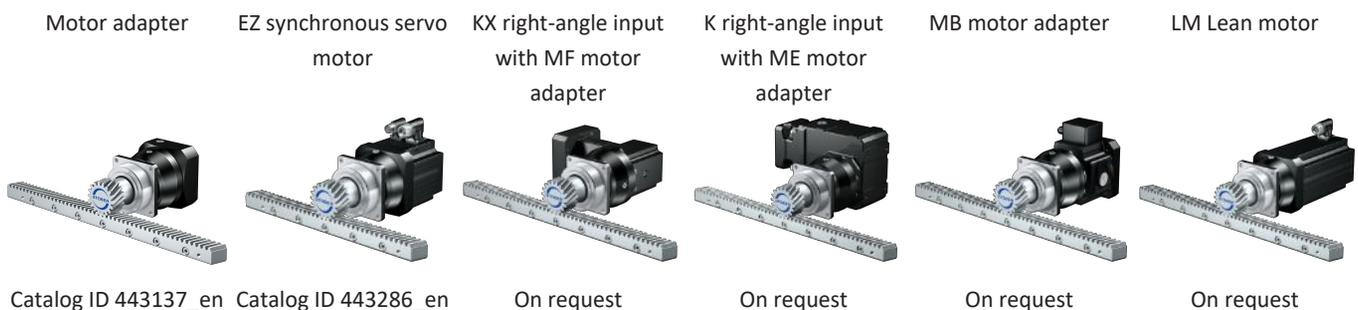

The corresponding catalogs can be found at <http://www.stober.de/en/downloads/>

Enter the ID of the catalog in the Search term field.

8.5.2 Motor adapter with EasyAdapt coupling (ME/MEL)

In this chapter, you will find a description of the EasyAdapt coupling.

Properties:

- Fast and easy motor attachment
- One-piece, rugged clamp coupling with expanding function
- Lowest mass moments of inertia for the highest dynamics
- Balanced for smooth running without vibration, even at high speeds
- Large selection of motor shaft diameters and lengths
- Error-free, thanks to exact centering of the motor
- For reduced backlash, the motor shaft bearing must have an axially backlash-free design



Fig. 1: EasyAdapt coupling

8.5.3 Motor adapter with FlexiAdapt coupling (MF)

In this chapter, you will find a description of the FlexiAdapt coupling.

Properties:

- Fast and easy motor attachment
- Rugged, laser-welded bellow coupling with expanding function
- With integrated thermal length compensation, compensates for linear expansion of the motor shaft
- Motor shaft decoupled from axial forces
- Balanced for smooth running without vibration, even at high speeds
- Large selection of motor shaft diameters and lengths
- Error-free, thanks to exact centering of the motor



Fig. 2: FlexiAdapt coupling

8.5.4 Gear rack

The gear rack used must have a right-hand design (19° 31' 42"); the load capacity must not be exceeded.

When using a STOBBER gear rack, please also observe the project configuration in the chapter [▶ 13.6](#).

8.5.5 Installation conditions

The specified torques and forces only apply when gear units are fastened on the machine side using screws of strength class 12.9. In addition, the gear housings must be adjusted at the pilot. The machine-side fit must be H7.

8.5.6 Lubricants

STOBER fills the gear units with the amount and type of lubricant specified on the nameplate.

You will receive lubricants for use in the food industry upon request.

8.5.6.1 Rack and pinion drive lubrication

Ensure permanent lubrication with the lubricants recommended in the chapter [▶ 13.5.1].

8.5.7 Other product features

Feature	Value
Max. permitted gear unit temperature (on the surface of the gear unit)	≤ 90 °C
Paint	Black RAL 9005
(ATEX) Directive 2014/34/EU (optional)	Not suitable.
Protection class: ²	
Planetary gear unit	IP65
Pinion/gear rack	IPXX

8.5.8 Direction of rotation

The input and output rotate in the same direction.

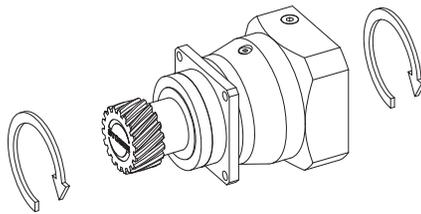

8.6 Project configuration

Project your drives using our SERVOfsoft designing software. Download SERVOfsoft free of charge after registration at <https://www.stoeber.de/en/services/info-servosoft/>.

It is the most convenient and reliable method of drive selection, as the entire torque/speed curve of the application is displayed and evaluated here in the curve of the geared motor.

In this chapter, only limit values for specific operating points can be taken into consideration for manual drive selection.

The formula symbols for values actually present in the application are marked with *.

An explanation of the formula symbols can be found in the chapter [▶ 14.1].

²Observe the protection class of all the components.

8.6.1 Drive selection

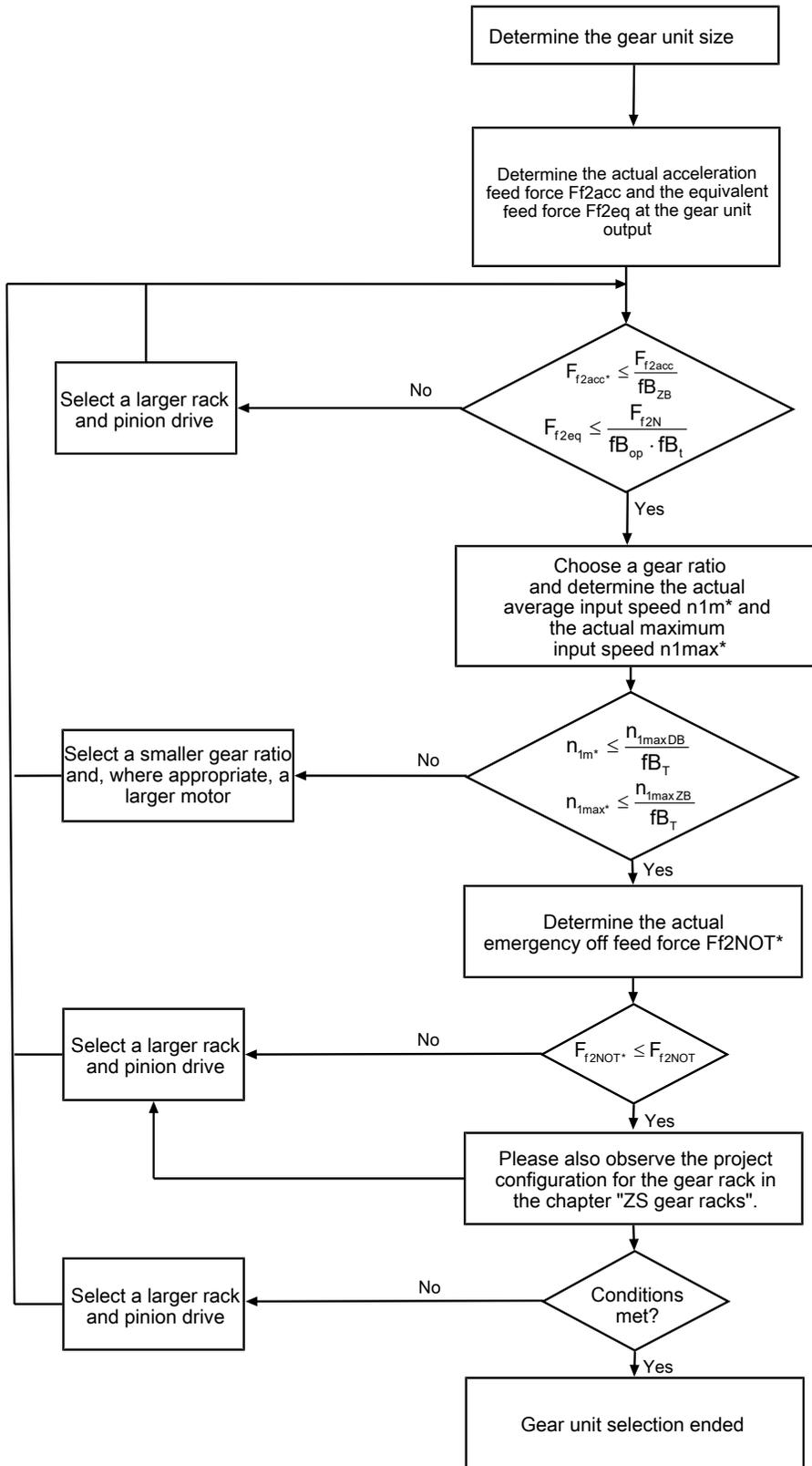

Refer to the selection tables for the values for i , n_{1maxDB} , n_{1maxZB} , F_{f2acc} , F_{f2N} and F_{f2NOT} . The forces depend on the pinion position (E or S). The speeds are partially dependent on the mounting position.

The values for fB_T , fB_{op} , fB_t and fB_{ZB} can be found in the corresponding tables in this chapter.

Example of cyclic operation

The following calculations are based on a representation of the power taken from the output based in accordance with the following example:

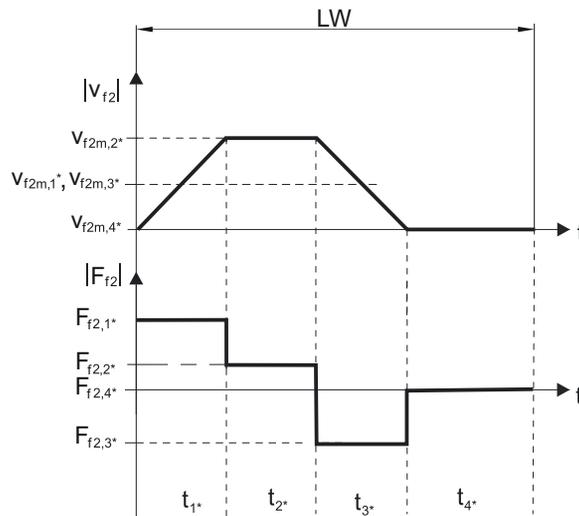
**Calculation of the actual maximum acceleration feed force**

$$F_{f2acc*} = m \cdot a^* + F_{L*}$$

Calculation of the actual average input speed

$$n_{1m*} = \frac{v_{f2m*} \cdot i}{d_0 \cdot \pi}$$

$$v_{f2m*} = \frac{|v_{f2m,1*}| \cdot t_{1*} + \dots + |v_{f2m,n*}| \cdot t_{n*}}{t_{1*} + \dots + t_{n*}}$$

If $t_{1*} + \dots + t_{3*} \geq 6$ min, determine v_{2m*} without the rest phase t_{4*} .

The values for the ratio i can be found in the selection tables.

Calculation of the actual emergency off feed force

$$F_{f2NOT*} = m \cdot a_{NOT*} + F_{L*}$$

Calculation of the actual equivalent feed force

$$F_{f2eq*} = \sqrt[3]{\frac{|v_{f2m,1*}| \cdot t_{1*} \cdot |F_{f2,1*}|^3 + \dots + |v_{f2m,n*}| \cdot t_{n*} \cdot |F_{f2,n*}|^3}{|v_{f2m,1*}| \cdot t_{1*} + \dots + |v_{f2m,n*}| \cdot t_{n*}}}$$

Operating factors

Operating mode	fB_{op}
Uniform continuous operation	1.00
Cyclic operation	1.00
Reversing load cyclic operation	1.00
Run time	fB_t
Daily runtime ≤ 8 h	1.00
Daily runtime ≤ 16 h	1.15
Daily runtime ≤ 24 h	1.20
Cyclic operation	fB_{ZB}
≤ 1000 load changes/hour (LW/h)	1.00
> 1000 load changes/hour (LW/h)	1.15

Temperature		f_{B_T}
Motor cooling	Surrounding temperature	
Motor with forced ventilation	$\leq 20\text{ }^\circ\text{C}$	0.9
	$\leq 30\text{ }^\circ\text{C}$	1.0
	$\leq 40\text{ }^\circ\text{C}$	1.15
Motor with convection cooling	$\leq 20\text{ }^\circ\text{C}$	1.0
	$\leq 30\text{ }^\circ\text{C}$	1.1
	$\leq 40\text{ }^\circ\text{C}$	1.25

Notes

- The maximum permitted gear unit temperature (see the "Other product features" chapter) must not be exceeded, as that could result in damage.
- For braking from full speed (for example, when the power fails or when setting up the machine), note the permitted gear unit feed forces (F_{f2acc} , F_{f2NOT}) in the selection tables.

8.6.2 Permitted breakdown torques at the gear unit input

For a horizontal mounting position of the motor, verify that the permitted breakdown torque at the gear unit input is not exceeded before installation on a STOBBER gear unit. You can find information for how to do that in this chapter.

Calculate the actual breakdown torque as follows:

$$M_{1k^*} = F_{1k^*} \cdot l_{sp} \leq M_{1k}$$

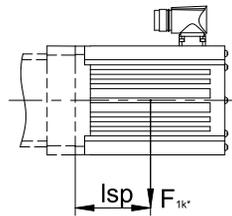

Type	M_{1k} [Nm]
P231_ME	10
P232_ME	10
P331_ME	20
P332_ME	10
P431_ME	40
P432_ME	20
P531_ME	80
P532_ME	40
P731_ME	200
P732_ME	80
P831_ME	400
P832_ME	200
P931_ME	800
P932_ME	400

The values also apply to the MEL and MF motor adapters.

8.6.3 Recommendation for radial shaft seal rings

For a duty cycle > 60% and higher surrounding temperatures, we recommend radial shaft seal rings made of FKM at the output.

Properties:

- Excellent temperature resistance
- High chemical stability
- Very good resistance to aging
- Excellent resistance in oils and greases
- For use in the food, beverage and pharmaceutical industries

Leak-proofness

Our gear units are equipped with high-quality radial shaft seal rings and checked for leaks. However, a leak cannot be fully ruled out over the length of use of a gear unit. If you use a gear unit with goods incompatible with the lubricant, you must take measures to prevent direct contact with the gear unit lubricant in case of a leak.

8.7 Additional documentation

Additional documentation related to the product can be found at <http://www.stoeber.de/en/downloads/>

Enter the ID of the documentation in the Search term field.

Documentation	ID
Operating manual gear units, geared motors P23 – P93	443356_en
Operating manual gear racks	443392_en

9 ZVPE rack and pinion drives

Table of contents

9.1	Overview	124
9.2	Selection tables	125
9.3	Dimensional drawings	127
9.3.1	Pinion position E	127
9.3.2	Pinion position S	128
9.4	Type designation	129
9.4.1	Nameplate	130
9.5	Product description	130
9.5.1	Input options	130
9.5.2	Motor adapter with EasyAdapt coupling (ME/MEL)	131
9.5.3	Gear rack	131
9.5.4	Installation conditions	131
9.5.5	Lubricants	132
9.5.6	Other product features	132
9.5.7	Direction of rotation	132
9.6	Project configuration	132
9.6.1	Drive selection	133
9.6.2	Permitted breakdown torques at the gear unit input	135
9.6.3	Radial shaft seal rings	135
9.7	Additional documentation	136

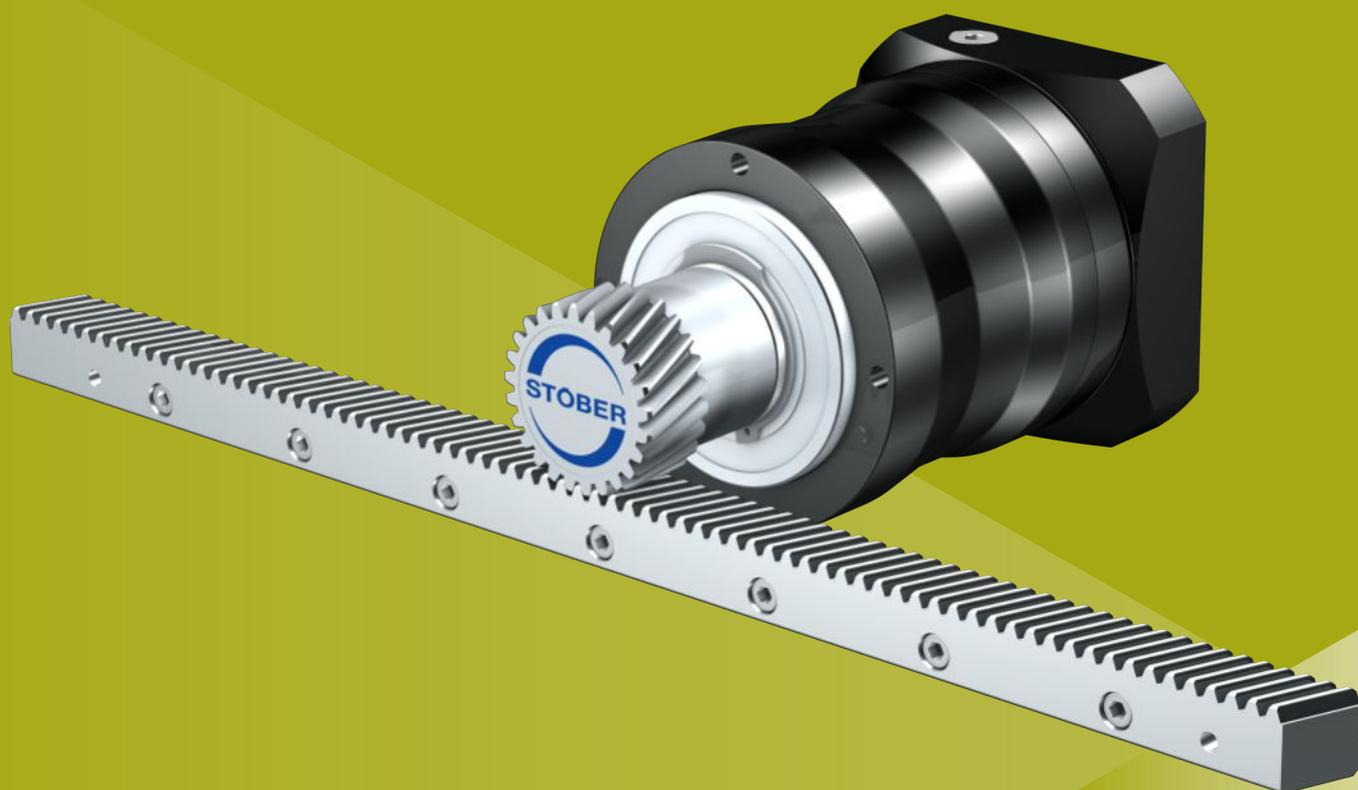

9 Rack and pinion drives

ZVPE

9.1 Overview

Cost-efficient planetary gear units with plug-on pinion

Features

Power density	★★★★☆
Linear clearance	★★★★☆
Price category	€
Smooth operation	★★★★☆
Linear rigidity	★★★★☆
Mass moment of inertia	★★★★☆
Ready-to-install drive solution	✓
Pinion gearing quality 6 (DIN 3962)	✓
Helical gearing	✓
Case-hardened and smoothed	✓

Key ★☆☆☆☆ good | ★★★★★ excellent
 € Economy | €€€€€ Premium

Technical data

m_n	2 – 3 mm
z	16 – 25
F_{f2acc}	1.7 – 6.1 kN
$v_{f2maxZB}$	0.14 – 4.5 m/s
Δs	40 – 83 μm

9.2 Selection tables

The technical data specified in the selection tables applies to:

- De-energized installation
- Permanent lubrication with the lubricants recommended in the chapter on gear racks [▶ 13.5.1]
- Case-hardened pinions, helical (left-hand 19° 31' 42"), gearing quality 6
- Installation altitudes up to 1000 m above sea level
- Surrounding temperatures from 0 °C to 40 °C
- Without consideration of the thermal limiting performance
- C_{in} : Pinion position S

For all other technical data, refer to <https://configurator.stoeber.de/en-US/>.

An explanation of the formula symbols can be found in the chapter [▶ 14.1].

i	Type	n_{1maxDB} [rpm]	n_{1maxZB} [rpm]	d_{MW} [mm]	$v_{f2maxZB}$ [m/s]	Δs [μm]	C_{lin} [N/μm]	m_n [mm]	z	d_0 [mm]	$F_{f2N,S}$ [kN]	$F_{f2N,E}$ [kN]	F_{f2accS} [kN]	F_{f2accE} [kN]	$F_{f2NOT,S}$ [kN]	$F_{f2NOT,E}$ [kN]	M_{2accS} [Nm]	M_{2accE} [Nm]
ZV2PE3 ($F_{f2acc,max} = 1,9 \text{ kN}$)																		
3.000	ZV216S_PE321_0030 ME	3500	6000	≤19	3.56	40	6.2	2	16	34.0	1.2	1.2	1.9	1.7	3.8	3.4	32	29
3.000	ZV216S_PE321_0030 MEL	3500	6000	≤24	3.56	40	6.2	2	16	34.0	1.2	1.2	1.9	1.7	3.8	3.4	32	29
4.000	ZV216S_PE321_0040 ME	3700	7000	≤19	3.11	40	6.4	2	16	34.0	1.4	1.4	1.9	1.7	3.8	3.4	32	29
4.000	ZV216S_PE321_0040 MEL	3700	7000	≤24	3.11	40	6.4	2	16	34.0	1.4	1.4	1.9	1.7	3.8	3.4	32	29
5.000	ZV216S_PE321_0050 ME	3700	7000	≤19	2.49	40	6.4	2	16	34.0	1.5	1.5	1.9	1.7	3.8	3.4	32	29
5.000	ZV216S_PE321_0050 MEL	3700	7000	≤24	2.49	40	6.4	2	16	34.0	1.5	1.5	1.9	1.7	3.8	3.4	32	29
7.000	ZV216S_PE321_0070 ME	4000	7000	≤19	1.78	40	6.4	2	16	34.0	1.5	1.5	1.9	1.7	3.8	3.4	32	29
7.000	ZV216S_PE321_0070 MEL	4000	7000	≤24	1.78	40	6.4	2	16	34.0	1.5	1.5	1.9	1.7	3.8	3.4	32	29
10.00	ZV216S_PE321_0100 ME	4000	7000	≤19	1.24	40	6.3	2	16	34.0	1.5	1.5	1.9	1.7	3.8	3.4	32	29
10.00	ZV216S_PE321_0100 MEL	4000	7000	≤24	1.24	40	6.3	2	16	34.0	1.5	1.5	1.9	1.7	3.8	3.4	32	29
16.00	ZV216S_PE322_0160 ME	4000	8000	≤14	0.89	49	6.4	2	16	34.0	1.8	1.7	1.9	1.7	3.8	3.4	32	29
16.00	ZV216S_PE322_0160 MEL	4000	8000	≤19	0.89	49	6.4	2	16	34.0	1.8	1.7	1.9	1.7	3.8	3.4	32	29
20.00	ZV216S_PE322_0200 ME	4000	8000	≤14	0.71	49	6.4	2	16	34.0	1.8	1.7	1.9	1.7	3.8	3.4	32	29
20.00	ZV216S_PE322_0200 MEL	4000	8000	≤19	0.71	49	6.4	2	16	34.0	1.8	1.7	1.9	1.7	3.8	3.4	32	29
25.00	ZV216S_PE322_0250 ME	4000	8000	≤14	0.57	49	6.4	2	16	34.0	1.8	1.7	1.9	1.7	3.8	3.4	32	29
25.00	ZV216S_PE322_0250 MEL	4000	8000	≤19	0.57	49	6.4	2	16	34.0	1.8	1.7	1.9	1.7	3.8	3.4	32	29
28.00	ZV216S_PE322_0280 ME	4000	8000	≤14	0.51	49	6.4	2	16	34.0	1.8	1.7	1.9	1.7	3.8	3.4	32	29
28.00	ZV216S_PE322_0280 MEL	4000	8000	≤19	0.51	49	6.4	2	16	34.0	1.8	1.7	1.9	1.7	3.8	3.4	32	29
35.00	ZV216S_PE322_0350 ME	4000	8000	≤14	0.41	49	6.4	2	16	34.0	1.8	1.7	1.9	1.7	3.8	3.4	32	29
35.00	ZV216S_PE322_0350 MEL	4000	8000	≤19	0.41	49	6.4	2	16	34.0	1.8	1.7	1.9	1.7	3.8	3.4	32	29
40.00	ZV216S_PE322_0400 ME	4500	8000	≤14	0.36	49	6.3	2	16	34.0	1.8	1.7	1.9	1.7	3.8	3.4	32	29
40.00	ZV216S_PE322_0400 MEL	4500	8000	≤19	0.36	49	6.3	2	16	34.0	1.8	1.7	1.9	1.7	3.8	3.4	32	29
50.00	ZV216S_PE322_0500 ME	4500	8000	≤14	0.28	49	6.4	2	16	34.0	1.8	1.7	1.9	1.7	3.8	3.4	32	29
50.00	ZV216S_PE322_0500 MEL	4500	8000	≤19	0.28	49	6.4	2	16	34.0	1.8	1.7	1.9	1.7	3.8	3.4	32	29
70.00	ZV216S_PE322_0700 ME	4500	8000	≤14	0.20	49	6.4	2	16	34.0	1.8	1.7	1.9	1.7	3.8	3.4	32	29
70.00	ZV216S_PE322_0700 MEL	4500	8000	≤19	0.20	49	6.4	2	16	34.0	1.8	1.7	1.9	1.7	3.8	3.4	32	29
100.0	ZV216S_PE322_1000 ME	4500	8000	≤14	0.14	49	6.3	2	16	34.0	1.8	1.7	1.9	1.7	3.8	3.4	32	29
100.0	ZV216S_PE322_1000 MEL	4500	8000	≤19	0.14	49	6.3	2	16	34.0	1.8	1.7	1.9	1.7	3.8	3.4	32	29
ZV2PE4 ($F_{f2acc,max} = 2,7 \text{ kN}$)																		
3.000	ZV220S_PE421_0030 ME	3000	5500	≤24	4.07	49	9.8	2	20	42.4	1.7	1.4	2.7	2.1	5.4	4.3	58	45
3.000	ZV220S_PE421_0030 MEL	3000	5500	≤32	4.07	49	9.9	2	20	42.4	1.7	1.4	2.7	2.1	5.4	4.3	58	45
4.000	ZV220S_PE421_0040 ME	3400	6000	≤24	3.33	49	10	2	20	42.4	1.9	1.6	2.7	2.1	5.4	4.3	58	45
4.000	ZV220S_PE421_0040 MEL	3400	6000	≤32	3.33	49	10	2	20	42.4	1.9	1.6	2.7	2.1	5.4	4.3	58	45
5.000	ZV220S_PE421_0050 ME	3400	6000	≤24	2.67	49	10	2	20	42.4	2.0	1.7	2.7	2.1	5.4	4.3	58	45
5.000	ZV220S_PE421_0050 MEL	3400	6000	≤32	2.67	49	10	2	20	42.4	2.0	1.7	2.7	2.1	5.4	4.3	58	45
7.000	ZV220S_PE421_0070 ME	3600	6000	≤24	1.91	49	9.9	2	20	42.4	2.2	1.9	2.7	2.1	5.4	4.3	58	45
7.000	ZV220S_PE421_0070 MEL	3600	6000	≤32	1.91	49	9.9	2	20	42.4	2.2	1.9	2.7	2.1	5.4	4.3	58	45
10.00	ZV220S_PE421_0100 ME	3600	6000	≤24	1.33	49	9.7	2	20	42.4	2.5	2.1	2.7	2.1	5.4	4.3	58	45
10.00	ZV220S_PE421_0100 MEL	3600	6000	≤32	1.33	49	9.7	2	20	42.4	2.5	2.1	2.7	2.1	5.4	4.3	58	45
16.00	ZV220S_PE422_0160 ME	3700	7000	≤19	0.97	62	10	2	20	42.4	2.7	2.1	2.7	2.1	5.4	4.3	58	45
16.00	ZV220S_PE422_0160 MEL	3700	7000	≤24	0.97	62	10	2	20	42.4	2.7	2.1	2.7	2.1	5.4	4.3	58	45
20.00	ZV220S_PE422_0200 ME	3700	7000	≤19	0.78	62	10	2	20	42.4	2.7	2.1	2.7	2.1	5.4	4.3	58	45
20.00	ZV220S_PE422_0200 MEL	3700	7000	≤24	0.78	62	10	2	20	42.4	2.7	2.1	2.7	2.1	5.4	4.3	58	45
25.00	ZV220S_PE422_0250 ME	3700	7000	≤19	0.62	62	10	2	20	42.4	2.7	2.1	2.7	2.1	5.4	4.3	58	45
25.00	ZV220S_PE422_0250 MEL	3700	7000	≤24	0.62	62	10	2	20	42.4	2.7	2.1	2.7	2.1	5.4	4.3	58	45
28.00	ZV220S_PE422_0280 ME	4000	7000	≤19	0.56	62	10	2	20	42.4	2.7	2.1	2.7	2.1	5.4	4.3	58	45
28.00	ZV220S_PE422_0280 MEL	4000	7000	≤24	0.56	62	10	2	20	42.4	2.7	2.1	2.7	2.1	5.4	4.3	58	45
35.00	ZV220S_PE422_0350 ME	4000	7000	≤19	0.44	62	10	2	20	42.4	2.7	2.1	2.7	2.1	5.4	4.3	58	45
35.00	ZV220S_PE422_0350 MEL	4000	7000	≤24	0.44	62	10	2	20	42.4	2.7	2.1	2.7	2.1	5.4	4.3	58	45
40.00	ZV220S_PE422_0400 ME	4000	7000	≤19	0.39	62	9.9	2	20	42.4	2.7	2.1	2.7	2.1	5.4	4.3	58	45

9.2 Selection tables 9 ZVPE rack and pinion drives

i	Type	n_{1maxDB}	n_{1maxZB}	d_{MW}	$v_{fzmaxZB}$	Δs	C_{lin}	m_n	z	d_0	$F_{fzN,S}$	$F_{fzN,E}$	F_{fzaccS}	F_{fzaccE}	$F_{fzNOT,S}$	$F_{fzNOT,E}$	M_{fzaccS}	M_{fzaccE}
		[rpm]	[rpm]	[mm]	[m/s]	[μ m]	[N/ μ m]	[mm]		[mm]	[kN]	[kN]	[kN]	[kN]	[kN]	[kN]	[Nm]	[Nm]
ZV2PE4 ($F_{fzacc,max} = 2,7$ kN)																		
40.00	ZV220S_PE422_0400 MEL	4000	7000	≤24	0.39	62	9.9	2	20	42.4	2.7	2.1	2.7	2.1	5.4	4.3	58	45
50.00	ZV220S_PE422_0500 ME	4000	7000	≤19	0.31	62	10	2	20	42.4	2.7	2.1	2.7	2.1	5.4	4.3	58	45
50.00	ZV220S_PE422_0500 MEL	4000	7000	≤24	0.31	62	10	2	20	42.4	2.7	2.1	2.7	2.1	5.4	4.3	58	45
70.00	ZV220S_PE422_0700 ME	4000	7000	≤19	0.22	62	9.7	2	20	42.4	2.7	2.1	2.7	2.1	5.4	4.3	58	45
70.00	ZV220S_PE422_0700 MEL	4000	7000	≤24	0.22	62	9.7	2	20	42.4	2.7	2.1	2.7	2.1	5.4	4.3	58	45
100.0	ZV220S_PE422_1000 ME	4000	7000	≤19	0.16	62	9.7	2	20	42.4	2.7	2.1	2.7	2.1	5.4	4.3	58	45
100.0	ZV220S_PE422_1000 MEL	4000	7000	≤24	0.16	62	9.7	2	20	42.4	2.7	2.1	2.7	2.1	5.4	4.3	58	45
ZV2PE5 ($F_{fzacc,max} = 6,1$ kN)																		
3.000	ZV225S_PE521_0030 ME	2500	4500	≤32	4.17	62	13	2	25	53.1	3.4	2.8	6.1	3.8	12	7.6	162	101
3.000	ZV225S_PE521_0030 MEL	2500	4500	≤38	4.17	62	13	2	25	53.1	3.4	2.8	6.1	3.8	12	7.6	162	101
4.000	ZV225S_PE521_0040 ME	2600	5000	≤32	3.47	62	13	2	25	53.1	4.5	3.1	6.1	3.8	12	7.6	162	101
4.000	ZV225S_PE521_0040 MEL	2600	5000	≤38	3.47	62	13	2	25	53.1	4.5	3.1	6.1	3.8	12	7.6	162	101
5.000	ZV225S_PE521_0050 ME	2600	5000	≤32	2.78	62	13	2	25	53.1	4.9	3.3	6.1	3.8	12	7.6	162	101
5.000	ZV225S_PE521_0050 MEL	2600	5000	≤38	2.78	62	13	2	25	53.1	4.9	3.3	6.1	3.8	12	7.6	162	101
7.000	ZV225S_PE521_0070 ME	2800	5000	≤32	1.98	62	13	2	25	53.1	4.9	3.7	6.1	3.8	12	7.6	162	101
7.000	ZV225S_PE521_0070 MEL	2800	5000	≤38	1.98	62	13	2	25	53.1	4.9	3.7	6.1	3.8	12	7.6	162	101
10.00	ZV225S_PE521_0100 ME	3000	5000	≤32	1.39	62	13	2	25	53.1	4.9	3.8	6.1	3.8	12	7.6	162	101
10.00	ZV225S_PE521_0100 MEL	3000	5000	≤38	1.39	62	13	2	25	53.1	4.9	3.8	6.1	3.8	12	7.6	162	101
16.00	ZV225S_PE522_0160 ME	3400	6000	≤24	1.04	77	13	2	25	53.1	6.0	3.8	6.1	3.8	12	7.6	162	101
16.00	ZV225S_PE522_0160 MEL	3400	6000	≤32	1.04	77	13	2	25	53.1	6.0	3.8	6.1	3.8	12	7.6	162	101
20.00	ZV225S_PE522_0200 ME	3400	6000	≤24	0.83	77	13	2	25	53.1	6.0	3.8	6.1	3.8	12	7.6	162	101
20.00	ZV225S_PE522_0200 MEL	3400	6000	≤32	0.83	77	13	2	25	53.1	6.0	3.8	6.1	3.8	12	7.6	162	101
25.00	ZV225S_PE522_0250 ME	3400	6000	≤24	0.67	77	13	2	25	53.1	6.0	3.8	6.1	3.8	12	7.6	162	101
25.00	ZV225S_PE522_0250 MEL	3400	6000	≤32	0.67	77	13	2	25	53.1	6.0	3.8	6.1	3.8	12	7.6	162	101
28.00	ZV225S_PE522_0280 ME	3600	6000	≤24	0.60	77	13	2	25	53.1	6.0	3.8	6.1	3.8	12	7.6	162	101
28.00	ZV225S_PE522_0280 MEL	3600	6000	≤32	0.60	77	13	2	25	53.1	6.0	3.8	6.1	3.8	12	7.6	162	101
35.00	ZV225S_PE522_0350 ME	3600	6000	≤24	0.48	77	13	2	25	53.1	6.0	3.8	6.1	3.8	12	7.6	162	101
35.00	ZV225S_PE522_0350 MEL	3600	6000	≤32	0.48	77	13	2	25	53.1	6.0	3.8	6.1	3.8	12	7.6	162	101
40.00	ZV225S_PE522_0400 ME	3600	6000	≤24	0.42	77	13	2	25	53.1	6.0	3.8	6.1	3.8	12	7.6	162	101
40.00	ZV225S_PE522_0400 MEL	3600	6000	≤32	0.42	77	13	2	25	53.1	6.0	3.8	6.1	3.8	12	7.6	162	101
50.00	ZV225S_PE522_0500 ME	3600	6000	≤24	0.33	77	13	2	25	53.1	6.0	3.8	6.1	3.8	12	7.6	162	101
50.00	ZV225S_PE522_0500 MEL	3600	6000	≤32	0.33	77	13	2	25	53.1	6.0	3.8	6.1	3.8	12	7.6	162	101
70.00	ZV225S_PE522_0700 ME	3600	6000	≤24	0.24	77	13	2	25	53.1	6.0	3.8	6.1	3.8	12	7.6	162	101
70.00	ZV225S_PE522_0700 MEL	3600	6000	≤32	0.24	77	13	2	25	53.1	6.0	3.8	6.1	3.8	12	7.6	162	101
100.0	ZV225S_PE522_1000 ME	3600	6000	≤24	0.17	77	13	2	25	53.1	6.0	3.8	6.1	3.8	12	7.6	162	101
100.0	ZV225S_PE522_1000 MEL	3600	6000	≤32	0.17	77	13	2	25	53.1	6.0	3.8	6.1	3.8	12	7.6	162	101
ZV3PE5 ($F_{fzacc,max} = 5,8$ kN)																		
3.000	ZV318S_PE521_0030 ME	2500	4500	≤32	4.50	67	14	3	18	57.3	3.1	2.9	5.8	3.9	12	7.8	166	111
3.000	ZV318S_PE521_0030 MEL	2500	4500	≤38	4.50	67	14	3	18	57.3	3.1	2.9	5.8	3.9	12	7.8	166	111
4.000	ZV318S_PE521_0040 ME	2600	5000	≤32	3.75	67	14	3	18	57.3	4.3	3.2	5.8	3.9	12	7.8	166	111
4.000	ZV318S_PE521_0040 MEL	2600	5000	≤38	3.75	67	14	3	18	57.3	4.3	3.2	5.8	3.9	12	7.8	166	111
5.000	ZV318S_PE521_0050 ME	2600	5000	≤32	3.00	67	14	3	18	57.3	4.5	3.4	5.8	3.9	12	7.8	166	111
5.000	ZV318S_PE521_0050 MEL	2600	5000	≤38	3.00	67	14	3	18	57.3	4.5	3.4	5.8	3.9	12	7.8	166	111
7.000	ZV318S_PE521_0070 ME	2800	5000	≤32	2.14	67	14	3	18	57.3	4.5	3.8	5.8	3.9	12	7.8	166	111
7.000	ZV318S_PE521_0070 MEL	2800	5000	≤38	2.14	67	14	3	18	57.3	4.5	3.8	5.8	3.9	12	7.8	166	111
10.00	ZV318S_PE521_0100 ME	3000	5000	≤32	1.50	67	14	3	18	57.3	4.5	3.9	5.8	3.9	12	7.8	166	111
10.00	ZV318S_PE521_0100 MEL	3000	5000	≤38	1.50	67	14	3	18	57.3	4.5	3.9	5.8	3.9	12	7.8	166	111
16.00	ZV318S_PE522_0160 ME	3400	6000	≤24	1.13	83	14	3	18	57.3	5.6	3.9	5.8	3.9	12	7.8	166	111
16.00	ZV318S_PE522_0160 MEL	3400	6000	≤32	1.13	83	14	3	18	57.3	5.6	3.9	5.8	3.9	12	7.8	166	111
20.00	ZV318S_PE522_0200 ME	3400	6000	≤24	0.90	83	14	3	18	57.3	5.6	3.9	5.8	3.9	12	7.8	166	111
20.00	ZV318S_PE522_0200 MEL	3400	6000	≤32	0.90	83	14	3	18	57.3	5.6	3.9	5.8	3.9	12	7.8	166	111
25.00	ZV318S_PE522_0250 ME	3400	6000	≤24	0.72	83	14	3	18	57.3	5.6	3.9	5.8	3.9	12	7.8	166	111
25.00	ZV318S_PE522_0250 MEL	3400	6000	≤32	0.72	83	14	3	18	57.3	5.6	3.9	5.8	3.9	12	7.8	166	111
28.00	ZV318S_PE522_0280 ME	3600	6000	≤24	0.64	83	14	3	18	57.3	5.6	3.9	5.8	3.9	12	7.8	166	111
28.00	ZV318S_PE522_0280 MEL	3600	6000	≤32	0.64	83	14	3	18	57.3	5.6	3.9	5.8	3.9	12	7.8	166	111
35.00	ZV318S_PE522_0350 ME	3600	6000	≤24	0.51	83	14	3	18	57.3	5.6	3.9	5.8	3.9	12	7.8	166	111
35.00	ZV318S_PE522_0350 MEL	3600	6000	≤32	0.51	83	14	3	18	57.3	5.6	3.9	5.8	3.9	12	7.8	166	111
40.00	ZV318S_PE522_0400 ME	3600	6000	≤24	0.45	83	14	3	18	57.3	5.6	3.9	5.8	3.9	12	7.8	166	111
40.00	ZV318S_PE522_0400 MEL	3600	6000	≤32	0.45	83	14	3	18	57.3	5.6	3.9	5.8	3.9	12	7.8	166	111
50.00	ZV318S_PE522_0500 ME	3600	6000	≤24	0.36	83	14	3	18	57.3	5.6	3.9	5.8	3.9	12	7.8	166	111
50.00	ZV318S_PE522_0500 MEL	3600	6000	≤32	0.36	83	14	3	18	57.3	5.6	3.9	5.8	3.9	12	7.8	166	111
70.00	ZV318S_PE522_0700 ME	3600	6000	≤24	0.26	83	14	3	18	57.3	5.6	3.9	5.8	3.9	12	7.8	166	111
70.00	ZV318S_PE522_0700 MEL	3600	6000	≤32	0.26	83	14	3	18	57.3	5.6	3.9	5.8	3.9	12	7.8	166	111
100.0	ZV318S_PE522_1000 ME	3600	6000	≤24	0.18	83	14	3	18	57.3	5.6	3.9	5.8	3.9	12	7.8	166	111
100.0	ZV318S_PE522_1000 MEL	3600	6000	≤32	0.18	83	14	3	18	57.3	5.6	3.9	5.8	3.9	12	7.8	166	111

9.3 Dimensional drawings

In this chapter, you can find the dimensions of the rack and pinion drives with motor adapter.

Dimension az in the tables of dimensions applies to STOBBER gear racks. In general: $az = \frac{1}{2} d_0 + h_0 + x \cdot mn$

The pinion of the rack and pinion drive is helical (left-hand $19^\circ 31' 42''$). The pinion gearing quality is 6.

Dimensions can exceed the specifications of ISO 2768-mK due to casting tolerances or accumulation of individual tolerances.

We reserve the right to make dimensional changes due to ongoing technical development.

You can download 3D models of our standard drives at <https://configurator.stoeber.de/en-US/>.

9.3.1 Pinion position E

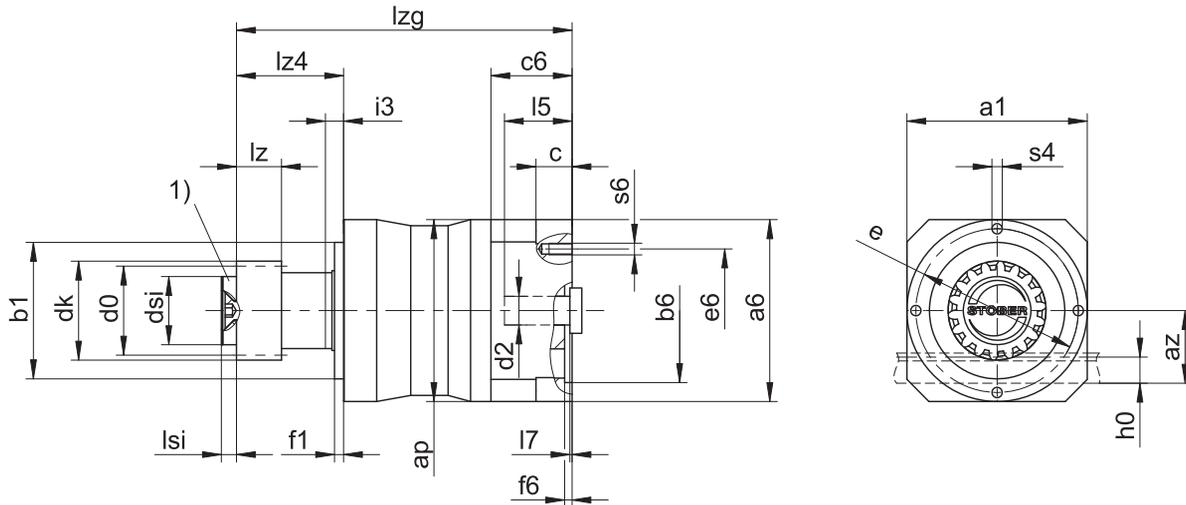

1) Axial locking (optional)

Output dimensions

Type	mn	$\varnothing a1$	ap	az	$\varnothing b1$	$\varnothing d0$	$\varnothing dk$	$\varnothing dsi$	$\varnothing e$	f1	h0	i3	lz	lz4	lsi	$\varnothing s4$	x
ZV216SEPE321_	2	70	72	39.98	52_{h6}	33.95	39.81	25	62	5	22	7	26	37.5	4	M5	0.5
ZV216SEPE322_	2	70	75	39.98	52_{h6}	33.95	39.81	25	62	5	22	7	26	37.5	4	M5	0.5
ZV220SEPE421_	2	90	98	44.02	68_{h6}	42.44	47.90	30	80	5	22	10	26	48.5	6	M6	0.4
ZV220SEPE422_	2	90	100	44.02	68_{h6}	42.44	47.90	30	80	5	22	10	26	48.5	6	M6	0.4
ZV225SEPE521_	2	120	120	49.33	90_{h6}	53.05	58.52	45	108	6	22	12	26	72.5	8	M8	0.4
ZV318SEPE521_	3	120	120	55.55	90_{h6}	57.30	65.01	45	108	6	26	12	31	72.5	8	M8	0.3
ZV225SEPE522_	2	120	120	49.33	90_{h6}	53.05	58.52	45	108	6	22	12	26	72.5	8	M8	0.4
ZV318SEPE522_	3	120	120	55.55	90_{h6}	57.30	65.01	45	108	6	26	12	31	72.5	8	M8	0.3

Example dimensions for the motor connection + total length

Type	$\varnothing b6$	$\varnothing e6$	$\varnothing d2max$	l5	$\square a6$	c	c6	f6	l7	l _{zg}	s6
ZV_PE321_ME	60^{H7}	75	19	41	75	18	41.5	3.5	4.0	152.0	M5
ZV_PE322_ME	40^{H7}	63	14	30	55	15	32.0	3.5	3.0	169.5	M5
ZV_PE421_ME	95^{H7}	115	24	41	100	21	42.5	4.0	3.5	169.5	M8
ZV_PE422_ME	60^{H7}	75	19	41	75	18	41.5	3.5	4.0	206.5	M5
ZV_PE521_ME	110^{H7}	130	32	51	120	24	54.0	4.0	4.5	224.5	M8
ZV_PE522_ME	95^{H7}	115	24	41	100	21	42.5	4.0	3.5	253.5	M8

In the table above, you will find example dimensions for the motor connection for the ME motor adapter.

Note that when dimension c is lengthened, dimensions c6, l5 and l_{zg} are also lengthened accordingly.

You will find additional motor connection dimensions for motor adapters ME and MEL in our STOBBER Configurator at <https://configurator.stoeber.de/en-US/>. Here, you can directly download a 3D model of your drive.

9.3.2 Pinion position S

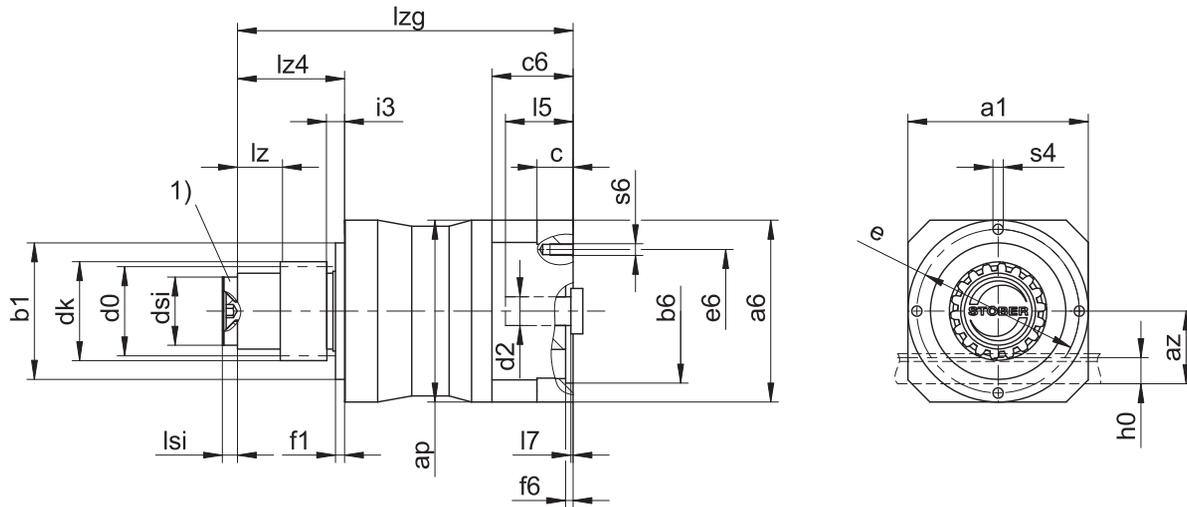

1) Axial locking (optional)

Output dimensions

Type	mn	Øa1	ap	az	Øb1	Ød0	Ødb	Ødk	Ødsi	Øe	f1	h0	i3	lb	lz	lz4	lsi	Øs4	x
ZV216SSPE321_	2	70	72	39.98	52 _{h6}	33.95	30	39.81	25	62	5	22	7	4.5	26	37.5	4	M5	0.5
ZV216SSPE322_	2	70	75	39.98	52 _{h6}	33.95	30	39.81	25	62	5	22	7	4.5	26	37.5	4	M5	0.5
ZV220SSPE421_	2	90	98	44.02	68 _{h6}	42.44	38	47.90	30	80	5	22	10	12.5	26	48.5	6	M6	0.4
ZV220SSPE422_	2	90	100	44.02	68 _{h6}	42.44	38	47.90	30	80	5	22	10	12.5	26	48.5	6	M6	0.4
ZV225SSPE521_	2	120	120	49.33	90 _{h6}	53.05	50	58.52	45	108	6	22	12	34.5	26	72.5	8	M8	0.4
ZV318SSPE521_	3	120	120	55.55	90 _{h6}	57.30	50	65.01	45	108	6	26	12	29.5	31	72.5	8	M8	0.3
ZV225SSPE522_	2	120	120	49.33	90 _{h6}	53.05	50	58.52	45	108	6	22	12	34.5	26	72.5	8	M8	0.4
ZV318SSPE522_	3	120	120	55.55	90 _{h6}	57.30	50	65.01	45	108	6	26	12	29.5	31	72.5	8	M8	0.3

Example dimensions for the motor connection + total length

Type	Øb6	Øe6	Ød2max	l5	□a6	c	c6	f6	l7	lzg	s6
ZV_PE321_ME	60 ^{H7}	75	19	41	75	18	41.5	3.5	4.0	152.0	M5
ZV_PE322_ME	40 ^{H7}	63	14	30	55	15	32.0	3.5	3.0	169.5	M5
ZV_PE421_ME	95 ^{H7}	115	24	41	100	21	42.5	4.0	3.5	169.5	M8
ZV_PE422_ME	60 ^{H7}	75	19	41	75	18	41.5	3.5	4.0	206.5	M5
ZV_PE521_ME	110 ^{H7}	130	32	51	120	24	54.0	4.0	4.5	224.5	M8
ZV_PE522_ME	95 ^{H7}	115	24	41	100	21	42.5	4.0	3.5	253.5	M8

In the table above, you will find example dimensions for the motor connection for the ME motor adapter.

Note that when dimension c is lengthened, dimensions c6, l5 and lzg are also lengthened accordingly.

You will find additional motor connection dimensions for motor adapters ME and MEL in our STOEGER Configurator at <https://configurator.stoeber.de/en-US/>. Here, you can directly download a 3D model of your drive.

9.4 Type designation

This chapter shows you an explanation of the type designation with the associated options.

Additional ordering information not included in the type designation can be found at the end of the chapter.

Example code

Z	V	2	20	S	S	PE	4	2	1	S	P	S	S	0050	ME
---	---	---	----	---	---	----	---	---	---	---	---	---	---	------	----

Explanation

Code	Designation	Design
Z	Type	Rack and pinion drive
V	Design	Plug-on pinion
2	Normal module	$m_n = 2$ mm (example)
20	Number of teeth	$z = 20$ (example)
S	Toothing	Helical (left-hand 19° 31' 42")
E	Pinion position	Shaft end
S		Shaft shoulder
PE	Type	Planetary gear unit
4	Size	4 (example)
2	Generation	Generation 2
1	Stages	Single-stage
2		Two-stage
S	Housing	Standard
P	Shaft	Solid shaft with feather key
S	Bearing	Standard bearing
S	Backlash	Standard
0050	Transmission ratio ($i \times 10$)	$i = 5$ (example)
ME	Motor adapter	Motor adapter with EasyAdapt coupling
MEL		Motor adapter with EasyAdapt coupling for large motors

To complete the type designation, also specify the following in your order:

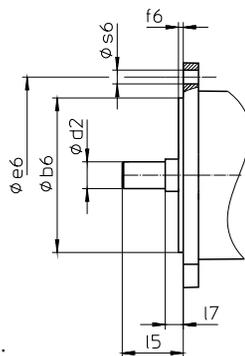

- Motor type or motor dimensions:

To choose a suitable motor connection, use the STOBBER Configurator at

<https://configurator.stoeber.de/en-US/> and choose your motor or the dimensions of the motor connection.

- For axial locking (optional), see the chapter [▶ 9.3]
- Socket wrench insert for mounting the motor on the gear unit using the ME/MEL motor adapter (optional)

In this product catalog, you will find all the information about rack and pinion drives with a motor adapter.

All input options available upon request are listed in the chapter [▶ 9.5.1].

9.4.1 Nameplate

An example gear unit nameplate is explained in the figure below.

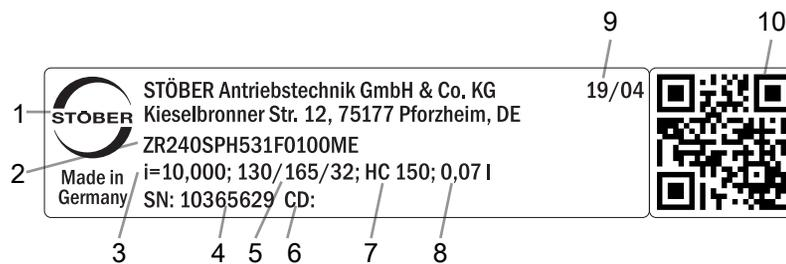

Code	Designation
1	Name of manufacturer
2	Type designation
3	Gear ratio of the gear unit
4	Serial number of the gear unit
5	Dimensions of the motor adapter (pilot/bolt circle/motor shaft diameter)
6	Customer-specific data
7	Lubricant specification
8	Lubricant fill volume
9	Date of manufacture (year/calendar week)
10	QR code (link to product information)

9.4.1.1 Supporting documents

You can view or download supporting documents for the product by reading off the serial number on the nameplate of the product and entering it at the following address online:

<https://id.stober.com>

Alternatively, you can use a suitable mobile device to scan in the QR code on the nameplate of the product in order to be linked to the supporting documents.

9.5 Product description

9.5.1 Input options

In this chapter, you will find all available input options:

ME motor adapter



Catalog ID 443137_en

EZ synchronous servo motor



Catalog ID 443286_en

LM Lean motor



On request

The corresponding catalogs can be found at <http://www.stober.de/en/downloads/>

Enter the ID of the catalog in the Search term field.

9.5.2 Motor adapter with EasyAdapt coupling (ME/MEL)

In this chapter, you will find a description of the EasyAdapt coupling.

Properties:

- Fast and easy motor attachment
- One-piece, rugged clamp coupling with expanding function
- Lowest mass moments of inertia for the highest dynamics
- Balanced for smooth running without vibration, even at high speeds
- Large selection of motor shaft diameters and lengths
- Error-free, thanks to exact centering of the motor
- For reduced backlash, the motor shaft bearing must have an axially backlash-free design



Fig. 1: EasyAdapt coupling

9.5.3 Gear rack

The gear rack used must have a right-hand design (19° 31' 42"); the load capacity must not be exceeded.

When using a STOBBER gear rack, please also observe the project configuration in the chapter [▶ 13.6](#).

9.5.4 Installation conditions

The specified torques and forces only apply when gear units are fastened on the machine side using screws of strength class 10.9. In addition, the gear housings must be adjusted at the pilot. The machine-side fit must be H7.

9.5.5 Lubricants

STOBER fills the gear units with the amount and type of lubricant specified on the nameplate.

You will receive lubricants for use in the food industry upon request.

9.5.5.1 Rack and pinion drive lubrication

Ensure permanent lubrication with the lubricants recommended in the chapter [▶ 13.5.1].

9.5.6 Other product features

Feature	Value
Max. permitted gear unit temperature (on the surface of the gear unit)	≤ 80 °C
Paint	Black RAL 9005
(ATEX) Directive 2014/34/EU (optional)	Not suitable
Protection class: ¹	
Planetary gear unit	IP64
Pinion/gear rack	IPXX

9.5.7 Direction of rotation

The input and output rotate in the same direction.

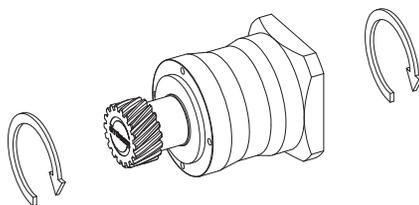

9.6 Project configuration

Project your drives using our SERVOSOFT designing software. Download SERVOSOFT free of charge after registration at <https://www.stoeber.de/en/services/info-servosoft/>.

It is the most convenient and reliable method of drive selection, as the entire torque/speed curve of the application is displayed and evaluated here in the curve of the geared motor.

In this chapter, only limit values for specific operating points can be taken into consideration for manual drive selection.

The formula symbols for values actually present in the application are marked with *.

An explanation of the formula symbols can be found in the chapter [▶ 14.1].

9.6.1 Drive selection

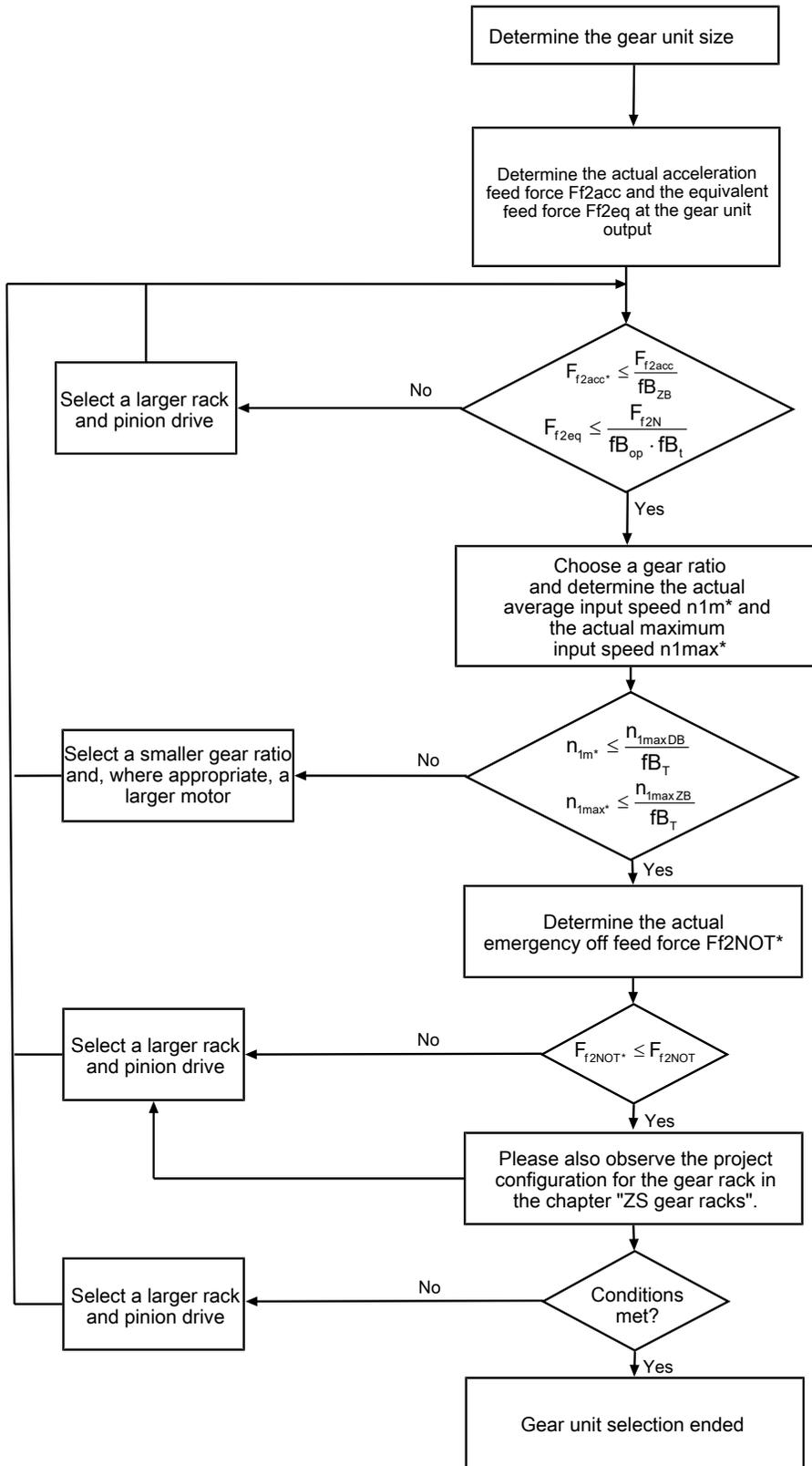

Refer to the selection tables for the values for i , n_{1maxDB} , n_{1maxZB} , F_{f2acc} , F_{f2N} and F_{f2NOT} . The forces depend on the pinion position (E or S). The speeds are partially dependent on the mounting position.

The values for fb_T , fb_{op} , fb_t and fb_{ZB} can be found in the corresponding tables in this chapter.

Example of cyclic operation

The following calculations are based on a representation of the power taken from the output based in accordance with the following example:

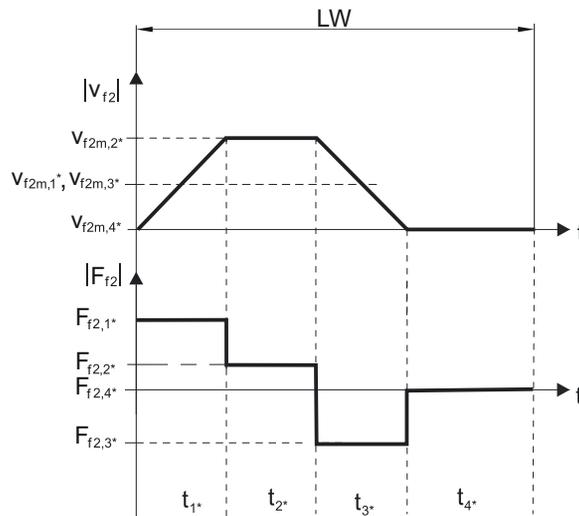

Calculation of the actual maximum acceleration feed force

$$F_{f2acc*} = m \cdot a^* + F_{L*}$$

Calculation of the actual average input speed

$$n_{1m*} = \frac{v_{f2m*} \cdot i}{d_0 \cdot \pi}$$

$$v_{f2m*} = \frac{|v_{f2m,1*}| \cdot t_{1*} + \dots + |v_{f2m,n*}| \cdot t_{n*}}{t_{1*} + \dots + t_{n*}}$$

If $t_{1*} + \dots + t_{3*} \geq 6$ min, determine v_{2m*} without the rest phase t_{4*} .

The values for the ratio i can be found in the selection tables.

Calculation of the actual emergency off feed force

$$F_{f2NOT*} = m \cdot a_{NOT*} + F_{L*}$$

Calculation of the actual equivalent feed force

$$F_{f2eq*} = \sqrt[3]{\frac{|v_{f2m,1*}| \cdot t_{1*} \cdot |F_{f2,1*}|^3 + \dots + |v_{f2m,n*}| \cdot t_{n*} \cdot |F_{f2,n*}|^3}{|v_{f2m,1*}| \cdot t_{1*} + \dots + |v_{f2m,n*}| \cdot t_{n*}}}$$

Operating factors

Operating mode	fB_{op}
Uniform continuous operation	1.00
Cyclic operation	1.00
Reversing load cyclic operation	1.00
Run time	fB_t
Daily runtime ≤ 8 h	1.00
Daily runtime ≤ 16 h	1.15
Daily runtime ≤ 24 h	1.20
Cyclic operation	fB_{ZB}
≤ 1000 load changes/hour (LW/h)	1.00
> 1000 load changes/hour (LW/h)	1.15

Temperature		f_{B_T}
Motor cooling	Surrounding temperature	
Motor with forced ventilation	$\leq 20\text{ }^\circ\text{C}$	0.9
	$\leq 30\text{ }^\circ\text{C}$	1.0
	$\leq 40\text{ }^\circ\text{C}$	1.15
Motor with convection cooling	$\leq 20\text{ }^\circ\text{C}$	1.0
	$\leq 30\text{ }^\circ\text{C}$	1.1
	$\leq 40\text{ }^\circ\text{C}$	1.25

Notes

- The maximum permitted gear unit temperature (see the "Other product features" chapter) must not be exceeded, as that could result in damage.
- For braking from full speed (for example, when the power fails or when setting up the machine), note the permitted gear unit feed forces (F_{f2acc} , F_{f2NOT}) in the selection tables.

9.6.2 Permitted breakdown torques at the gear unit input

For a horizontal mounting position of the motor, verify that the permitted breakdown torque at the gear unit input is not exceeded before installation on a STOBBER gear unit. You can find information for how to do that in this chapter.

Calculate the actual breakdown torque as follows:

$$M_{1k^*} = F_{1k^*} \cdot l_{sp} \leq M_{1k}$$

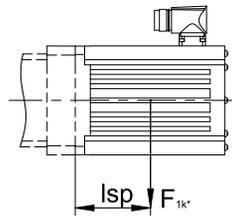

Type	M_{1k} [Nm]
PE221_ME	10
PE222_ME	10
PE321_ME	20
PE322_ME	10
PE421_ME	40
PE422_ME	20
PE521_ME	80
PE522_ME	40

The values also apply to the MEL motor adapter.

9.6.3 Radial shaft seal rings

Leak-proofness

Our gear units are equipped with high-quality radial shaft seal rings and checked for leaks. However, a leak cannot be fully ruled out over the length of use of a gear unit. If you use a gear unit with goods incompatible with the lubricant, you must take measures to prevent direct contact with the gear unit lubricant in case of a leak.

9.7 Additional documentation

Additional documentation related to the product can be found at

<http://www.stoeber.de/en/downloads/>

Enter the ID of the documentation in the Search term field.

Documentation	ID
Operating manual for PE22 – PE52 planetary gear units and planetary geared motors	443252_en
Operating manual gear racks	443392_en

10 ZVKS rack and pinion drives

Table of contents

10.1 Overview	138
10.2 Selection tables	139
10.3 Dimensional drawings	142
10.3.1 Pinion position E	143
10.3.2 Pinion position S	144
10.3.3 Oil expansion tank	145
10.4 Type designation	146
10.4.1 Nameplate	147
10.5 Product description	147
10.5.1 Input options	147
10.5.2 Motor adapter with EasyAdapt coupling (ME/MEL)	148
10.5.3 Gear rack	148
10.5.4 Installation conditions	148
10.5.5 Mounting positions	149
10.5.6 Lubricants	149
10.5.7 Position of locking screw access	150
10.5.8 Other product features	150
10.5.9 Direction of rotation	150
10.6 Project configuration	150
10.6.1 Drive selection	151
10.6.2 Permitted breakdown torques at the gear unit input	153
10.6.3 Recommendation for radial shaft seal rings	153
10.6.4 Oil expansion tank	154
10.7 Additional documentation	154

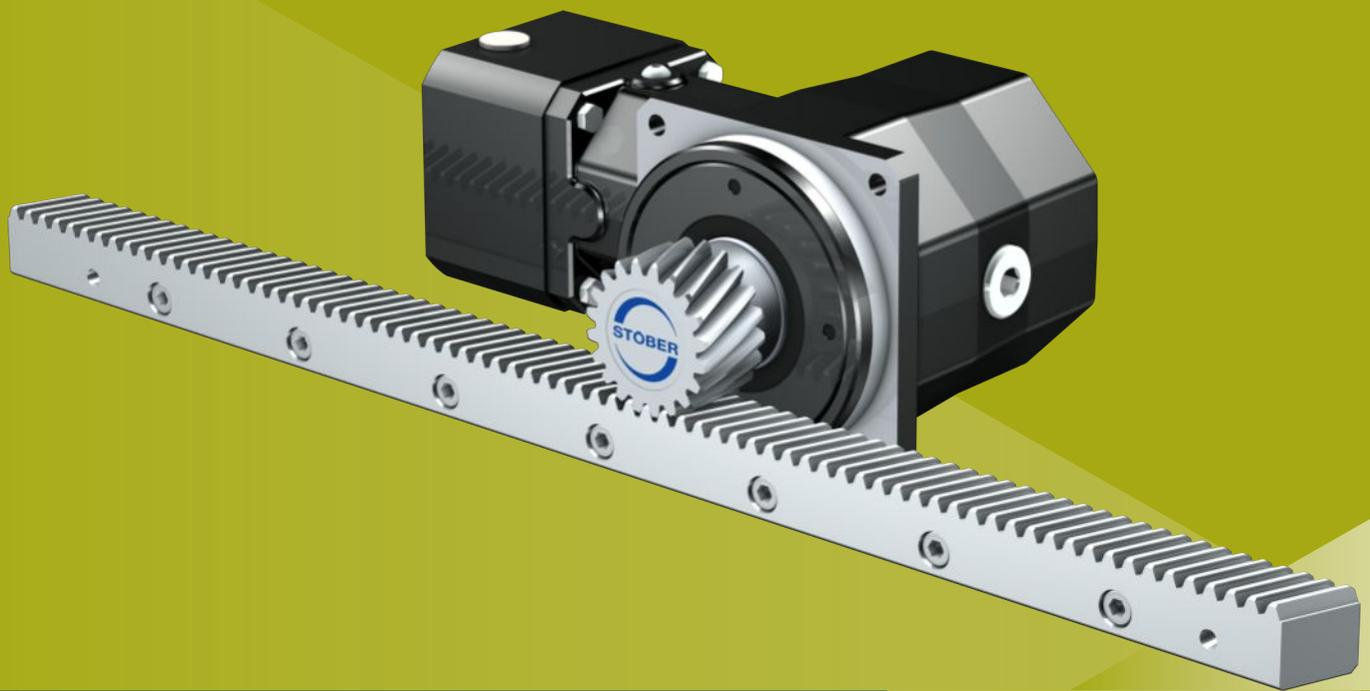

10

Rack and pinion drives

ZVKS

10.1 Overview

Right-angle servo gear units with plug-on pinion

Features

- Power density ★★★★★
- Linear clearance ★★★★★
- Price category €€€
- Smooth operation ★★★★★
- Linear rigidity ★★★★★
- Mass moment of inertia ★★★★★
- Ready-to-install drive solution ✓
- Pinion gearing quality 6 (DIN 3962) ✓
- Helical gearing ✓
- Case-hardened and smoothed ✓

Key ★☆☆☆☆ good | ★★★★★ excellent
 € Economy | €€€€€ Premium

Technical data

m_n	2 – 4 mm
z	18 – 25
F_{f2acc}	3.2 – 11 kN
$v_{f2maxZB}$	0.07 – 3 m/s
Δs	37 – 44 μm

10.2 Selection tables

The technical data specified in the selection tables applies to:

- De-energized installation
- Permanent lubrication with the lubricants recommended in the chapter on gear racks [▶ 13.5.1]
- Case-hardened pinions, helical (left-hand 19° 31' 42"), gearing quality 6
- Installation altitudes up to 1000 m above sea level
- Surrounding temperatures from 0 °C to 40 °C
- Without consideration of the thermal limiting performance
- C_{in} : Pinion position S

For all other technical data, refer to <https://configurator.stoeber.de/en-US/>.

An explanation of the formula symbols can be found in the chapter [▶ 14.1].

i	Type	n_{1maxDB} [rpm]	n_{1maxZB} [rpm]	d_{MW} [mm]	$v_{f2maxZB}$ [m/s]	Δs [μm]	C_{in} [N/μm]	m_n [mm]	z	d_0 [mm]	$F_{f2N,S}$ [kN]	$F_{f2N,E}$ [kN]	F_{f2accS} [kN]	F_{f2accE} [kN]	$F_{f2NOT,S}$ [kN]	$F_{f2NOT,E}$ [kN]	M_{2accS} [Nm]	M_{2accE} [Nm]
ZV2KS4 ($F_{f2acc,max} = 4,2 \text{ kN}$)																		
6.000	ZV220S_KS402_0060 ME	3000	6000	≤19	2.22	37	35	2	20	42.4	2.8	2.8	4.2	3.2	6.6	6.4	90	68
6.000	ZV220S_KS402_0060 MEL	3000	6000	≤24	2.22	37	36	2	20	42.4	2.8	2.8	4.2	3.2	6.6	6.4	90	68
8.000	ZV220S_KS402_0080 ME	3500	6000	≤19	1.67	37	36	2	20	42.4	3.1	3.1	4.2	3.2	6.6	6.4	90	68
8.000	ZV220S_KS402_0080 MEL	3500	6000	≤24	1.67	37	36	2	20	42.4	3.1	3.1	4.2	3.2	6.6	6.4	90	68
10.00	ZV220S_KS402_0100 ME	3800	6000	≤19	1.33	37	36	2	20	42.4	3.1	3.1	4.2	3.2	6.6	6.4	90	68
10.00	ZV220S_KS402_0100 MEL	3800	6000	≤24	1.33	37	36	2	20	42.4	3.1	3.1	4.2	3.2	6.6	6.4	90	68
14.00	ZV220S_KS402_0140 ME	4000	6000	≤19	0.95	37	36	2	20	42.4	3.1	3.1	4.2	3.2	6.6	6.4	90	68
14.00	ZV220S_KS402_0140 MEL	4000	6000	≤24	0.95	37	36	2	20	42.4	3.1	3.1	4.2	3.2	6.6	6.4	90	68
20.00	ZV220S_KS402_0200 ME	4000	6000	≤19	0.67	37	36	2	20	42.4	2.8	2.8	4.2	3.2	6.6	6.4	90	68
20.00	ZV220S_KS402_0200 MEL	4000	6000	≤24	0.67	37	36	2	20	42.4	2.8	2.8	4.2	3.2	6.6	6.4	90	68
24.00	ZV220S_KS403_0240 ME	3500	6000	≤14	0.56	37	36	2	20	42.4	2.8	2.8	4.2	3.2	6.6	6.4	90	68
24.00	ZV220S_KS403_0240 MEL	3500	6000	≤19	0.56	37	36	2	20	42.4	2.8	2.8	4.2	3.2	6.6	6.4	90	68
32.00	ZV220S_KS403_0320 ME	3500	6000	≤14	0.42	37	36	2	20	42.4	3.1	3.1	4.2	3.2	6.6	6.4	90	68
32.00	ZV220S_KS403_0320 MEL	3500	6000	≤19	0.42	37	36	2	20	42.4	3.1	3.1	4.2	3.2	6.6	6.4	90	68
40.00	ZV220S_KS403_0400 ME	3500	6000	≤14	0.33	37	36	2	20	42.4	3.1	3.1	4.2	3.2	6.6	6.4	90	68
40.00	ZV220S_KS403_0400 MEL	3500	6000	≤19	0.33	37	36	2	20	42.4	3.1	3.1	4.2	3.2	6.6	6.4	90	68
50.00	ZV220S_KS403_0500 ME	4000	6000	≤14	0.27	37	36	2	20	42.4	3.1	3.1	4.2	3.2	6.6	6.4	90	68
50.00	ZV220S_KS403_0500 MEL	4000	6000	≤19	0.27	37	36	2	20	42.4	3.1	3.1	4.2	3.2	6.6	6.4	90	68
70.00	ZV220S_KS403_0700 ME	4500	6000	≤14	0.19	37	36	2	20	42.4	3.1	3.1	4.2	3.2	6.6	6.4	90	68
70.00	ZV220S_KS403_0700 MEL	4500	6000	≤19	0.19	37	36	2	20	42.4	3.1	3.1	4.2	3.2	6.6	6.4	90	68
80.00	ZV220S_KS403_0800 ME	4500	6000	≤14	0.17	37	36	2	20	42.4	3.1	3.1	4.2	3.2	6.6	6.4	90	68
80.00	ZV220S_KS403_0800 MEL	4500	6000	≤19	0.17	37	36	2	20	42.4	3.1	3.1	4.2	3.2	6.6	6.4	90	68
100.00	ZV220S_KS403_1000 ME	4500	6000	≤14	0.13	37	36	2	20	42.4	3.1	3.1	4.2	3.2	6.6	6.4	90	68
100.00	ZV220S_KS403_1000 MEL	4500	6000	≤19	0.13	37	36	2	20	42.4	3.1	3.1	4.2	3.2	6.6	6.4	90	68
140.00	ZV220S_KS403_1400 ME	4500	6000	≤14	0.10	37	36	2	20	42.4	3.1	3.1	4.2	3.2	6.6	6.4	90	68
140.00	ZV220S_KS403_1400 MEL	4500	6000	≤19	0.10	37	36	2	20	42.4	3.1	3.1	4.2	3.2	6.6	6.4	90	68
200.00	ZV220S_KS403_2000 ME	4500	6000	≤14	0.07	37	36	2	20	42.4	2.8	2.8	4.2	3.2	6.6	6.4	90	68
200.00	ZV220S_KS403_2000 MEL	4500	6000	≤19	0.07	37	36	2	20	42.4	2.8	2.8	4.2	3.2	6.6	6.4	90	68
ZV2KS5 ($F_{f2acc,max} = 7,5 \text{ kN}$)																		
6.000	ZV225S_KS502_0060 ME	2500	5500	≤24	2.55	39	45	2	25	53.1	3.8	3.8	7.5	5.0	11	10	200	134
6.000	ZV225S_KS502_0060 MEL	2500	5500	≤32	2.55	39	45	2	25	53.1	3.8	3.8	7.5	5.0	11	10	200	134
8.000	ZV225S_KS502_0080 ME	2800	6000	≤24	2.08	39	45	2	25	53.1	4.7	4.7	7.5	5.0	11	10	200	134
8.000	ZV225S_KS502_0080 MEL	2800	6000	≤32	2.08	39	45	2	25	53.1	4.7	4.7	7.5	5.0	11	10	200	134
10.00	ZV225S_KS502_0100 ME	3000	6000	≤24	1.67	39	45	2	25	53.1	4.7	4.7	7.5	5.0	11	10	200	134
10.00	ZV225S_KS502_0100 MEL	3000	6000	≤32	1.67	39	46	2	25	53.1	4.7	4.7	7.5	5.0	11	10	200	134
14.00	ZV225S_KS502_0140 ME	3200	6000	≤24	1.19	39	45	2	25	53.1	4.7	4.7	7.5	5.0	11	10	200	134
14.00	ZV225S_KS502_0140 MEL	3200	6000	≤32	1.19	39	46	2	25	53.1	4.7	4.7	7.5	5.0	11	10	200	134
20.00	ZV225S_KS502_0200 ME	3500	6000	≤24	0.83	39	46	2	25	53.1	4.5	4.5	7.5	5.0	11	10	200	134
20.00	ZV225S_KS502_0200 MEL	3500	6000	≤32	0.83	39	46	2	25	53.1	4.5	4.5	7.5	5.0	11	10	200	134
24.00	ZV225S_KS503_0240 ME	3100	6000	≤19	0.69	39	46	2	25	53.1	3.8	3.8	7.5	5.0	11	10	200	134
24.00	ZV225S_KS503_0240 MEL	3100	6000	≤24	0.69	39	46	2	25	53.1	3.8	3.8	7.5	5.0	11	10	200	134
32.00	ZV225S_KS503_0320 ME	3100	6000	≤19	0.52	39	46	2	25	53.1	4.7	4.7	7.5	5.0	11	10	200	134
32.00	ZV225S_KS503_0320 MEL	3100	6000	≤24	0.52	39	46	2	25	53.1	4.7	4.7	7.5	5.0	11	10	200	134
40.00	ZV225S_KS503_0400 ME	3100	6000	≤19	0.42	39	46	2	25	53.1	4.7	4.7	7.5	5.0	11	10	200	134
40.00	ZV225S_KS503_0400 MEL	3100	6000	≤24	0.42	39	46	2	25	53.1	4.7	4.7	7.5	5.0	11	10	200	134
50.00	ZV225S_KS503_0500 ME	3500	6000	≤19	0.33	39	46	2	25	53.1	4.7	4.7	7.5	5.0	11	10	200	134
50.00	ZV225S_KS503_0500 MEL	3500	6000	≤24	0.33	39	46	2	25	53.1	4.7	4.7	7.5	5.0	11	10	200	134
70.00	ZV225S_KS503_0700 ME	4200	6000	≤19	0.24	39	46	2	25	53.1	4.7	4.7	7.5	5.0	11	10	200	134
70.00	ZV225S_KS503_0700 MEL	4200	6000	≤24	0.24	39	46	2	25	53.1	4.7	4.7	7.5	5.0	11	10	200	134
80.00	ZV225S_KS503_0800 ME	4200	6000	≤19	0.21	39	46	2	25	53.1	4.7	4.7	7.5	5.0	11	10	200	134

10.2 Selection tables 10 ZVKs rack and pinion drives

i	Type	n_{1maxDB}	n_{1maxZB}	d_{MW}	$v_{f2maxZB}$	Δs	C_{lin}	m_n	z	d_0	$F_{f2N,S}$	$F_{f2N,E}$	F_{f2accS}	F_{f2accE}	$F_{f2NOT,S}$	$F_{f2NOT,E}$	M_{2accS}	M_{2accE}
		[rpm]	[rpm]	[mm]	[m/s]	[μm]	[N/ μm]	[mm]		[mm]	[kN]	[kN]	[kN]	[kN]	[kN]	[kN]	[Nm]	[Nm]
ZV2KS5 ($F_{f2acc,max} = 7,5 \text{ kN}$)																		
80.00	ZV225S_KS503_0800 MEL	4200	6000	≤24	0.21	39	46	2	25	53.1	4.7	4.7	7.5	5.0	11	10	200	134
100.0	ZV225S_KS503_1000 ME	4200	6000	≤19	0.17	39	46	2	25	53.1	4.7	4.7	7.5	5.0	11	10	200	134
100.0	ZV225S_KS503_1000 MEL	4200	6000	≤24	0.17	39	46	2	25	53.1	4.7	4.7	7.5	5.0	11	10	200	134
140.0	ZV225S_KS503_1400 ME	4200	6000	≤19	0.12	39	46	2	25	53.1	4.7	4.7	7.5	5.0	11	10	200	134
140.0	ZV225S_KS503_1400 MEL	4200	6000	≤24	0.12	39	46	2	25	53.1	4.7	4.7	7.5	5.0	11	10	200	134
200.0	ZV225S_KS503_2000 ME	4200	6000	≤19	0.08	39	46	2	25	53.1	4.5	4.5	7.5	5.0	11	10	200	134
200.0	ZV225S_KS503_2000 MEL	4200	6000	≤24	0.08	39	46	2	25	53.1	4.5	4.5	7.5	5.0	11	10	200	134
ZV3KS5 ($F_{f2acc,max} = 7,0 \text{ kN}$)																		
6.000	ZV318S_KS502_0060 ME	2500	5500	≤24	2.75	42	43	3	18	57.3	3.5	3.5	7.0	5.2	10	10	200	148
6.000	ZV318S_KS502_0060 MEL	2500	5500	≤32	2.75	42	43	3	18	57.3	3.5	3.5	7.0	5.2	10	10	200	148
8.000	ZV318S_KS502_0080 ME	2800	6000	≤24	2.25	42	43	3	18	57.3	4.4	4.4	7.0	5.2	10	10	200	148
8.000	ZV318S_KS502_0080 MEL	2800	6000	≤32	2.25	42	44	3	18	57.3	4.4	4.4	7.0	5.2	10	10	200	148
10.00	ZV318S_KS502_0100 ME	3000	6000	≤24	1.80	42	44	3	18	57.3	4.4	4.4	7.0	5.2	10	10	200	148
10.00	ZV318S_KS502_0100 MEL	3000	6000	≤32	1.80	42	44	3	18	57.3	4.4	4.4	7.0	5.2	10	10	200	148
14.00	ZV318S_KS502_0140 ME	3200	6000	≤24	1.29	42	44	3	18	57.3	4.4	4.4	7.0	5.2	10	10	200	148
14.00	ZV318S_KS502_0140 MEL	3200	6000	≤32	1.29	42	44	3	18	57.3	4.4	4.4	7.0	5.2	10	10	200	148
20.00	ZV318S_KS502_0200 ME	3500	6000	≤24	0.90	42	44	3	18	57.3	4.2	4.2	7.0	5.2	10	10	200	148
20.00	ZV318S_KS502_0200 MEL	3500	6000	≤32	0.90	42	44	3	18	57.3	4.2	4.2	7.0	5.2	10	10	200	148
24.00	ZV318S_KS503_0240 ME	3100	6000	≤19	0.75	42	44	3	18	57.3	3.5	3.5	7.0	5.2	10	10	200	148
24.00	ZV318S_KS503_0240 MEL	3100	6000	≤24	0.75	42	44	3	18	57.3	3.5	3.5	7.0	5.2	10	10	200	148
32.00	ZV318S_KS503_0320 ME	3100	6000	≤19	0.56	42	44	3	18	57.3	4.4	4.4	7.0	5.2	10	10	200	148
32.00	ZV318S_KS503_0320 MEL	3100	6000	≤24	0.56	42	44	3	18	57.3	4.4	4.4	7.0	5.2	10	10	200	148
40.00	ZV318S_KS503_0400 ME	3100	6000	≤19	0.45	42	44	3	18	57.3	4.4	4.4	7.0	5.2	10	10	200	148
40.00	ZV318S_KS503_0400 MEL	3100	6000	≤24	0.45	42	44	3	18	57.3	4.4	4.4	7.0	5.2	10	10	200	148
50.00	ZV318S_KS503_0500 ME	3500	6000	≤19	0.36	42	44	3	18	57.3	4.4	4.4	7.0	5.2	10	10	200	148
50.00	ZV318S_KS503_0500 MEL	3500	6000	≤24	0.36	42	44	3	18	57.3	4.4	4.4	7.0	5.2	10	10	200	148
70.00	ZV318S_KS503_0700 ME	4200	6000	≤19	0.26	42	44	3	18	57.3	4.4	4.4	7.0	5.2	10	10	200	148
70.00	ZV318S_KS503_0700 MEL	4200	6000	≤24	0.26	42	44	3	18	57.3	4.4	4.4	7.0	5.2	10	10	200	148
80.00	ZV318S_KS503_0800 ME	4200	6000	≤19	0.23	42	44	3	18	57.3	4.4	4.4	7.0	5.2	10	10	200	148
80.00	ZV318S_KS503_0800 MEL	4200	6000	≤24	0.23	42	44	3	18	57.3	4.4	4.4	7.0	5.2	10	10	200	148
100.0	ZV318S_KS503_1000 ME	4200	6000	≤19	0.18	42	44	3	18	57.3	4.4	4.4	7.0	5.2	10	10	200	148
100.0	ZV318S_KS503_1000 MEL	4200	6000	≤24	0.18	42	44	3	18	57.3	4.4	4.4	7.0	5.2	10	10	200	148
140.0	ZV318S_KS503_1400 ME	4200	6000	≤19	0.13	42	44	3	18	57.3	4.4	4.4	7.0	5.2	10	10	200	148
140.0	ZV318S_KS503_1400 MEL	4200	6000	≤24	0.13	42	44	3	18	57.3	4.4	4.4	7.0	5.2	10	10	200	148
200.0	ZV318S_KS503_2000 ME	4200	6000	≤19	0.09	42	44	3	18	57.3	4.2	4.2	7.0	5.2	10	10	200	148
200.0	ZV318S_KS503_2000 MEL	4200	6000	≤24	0.09	42	44	3	18	57.3	4.2	4.2	7.0	5.2	10	10	200	148
ZV3KS7 ($F_{f2acc,max} = 11 \text{ kN}$)																		
6.000	ZV322S_KS702_0060 ME	2100	4500	≤32	2.75	41	66	3	22	70.0	6.9	6.4	11	6.4	17	13	400	223
6.000	ZV322S_KS702_0060 MEL	2100	4500	≤38	2.75	41	67	3	22	70.0	6.9	6.4	11	6.4	17	13	400	223
8.000	ZV322S_KS702_0080 ME	2500	5000	≤32	2.29	41	67	3	22	70.0	7.1	6.4	11	6.4	17	13	400	223
8.000	ZV322S_KS702_0080 MEL	2500	5000	≤38	2.29	41	67	3	22	70.0	7.1	6.4	11	6.4	17	13	400	223
10.00	ZV322S_KS702_0100 ME	2800	6000	≤32	2.20	41	67	3	22	70.0	7.1	6.4	11	6.4	17	13	400	223
10.00	ZV322S_KS702_0100 MEL	2800	6000	≤38	2.20	41	67	3	22	70.0	7.1	6.4	11	6.4	17	13	400	223
14.00	ZV322S_KS702_0140 ME	3000	6000	≤32	1.57	41	67	3	22	70.0	7.1	6.4	11	6.4	17	13	400	223
14.00	ZV322S_KS702_0140 MEL	3000	6000	≤38	1.57	41	67	3	22	70.0	7.1	6.4	11	6.4	17	13	400	223
20.00	ZV322S_KS702_0200 ME	3200	6000	≤32	1.10	41	67	3	22	70.0	7.1	6.4	11	6.4	17	13	400	223
20.00	ZV322S_KS702_0200 MEL	3200	6000	≤38	1.10	41	68	3	22	70.0	7.1	6.4	11	6.4	17	13	400	223
24.00	ZV322S_KS703_0240 ME	3000	6000	≤24	0.92	41	67	3	22	70.0	6.9	6.4	11	6.4	17	13	400	223
24.00	ZV322S_KS703_0240 MEL	3000	6000	≤32	0.92	41	68	3	22	70.0	6.9	6.4	11	6.4	17	13	400	223
32.00	ZV322S_KS703_0320 ME	3000	6000	≤24	0.69	41	68	3	22	70.0	7.1	6.4	11	6.4	17	13	400	223
32.00	ZV322S_KS703_0320 MEL	3000	6000	≤32	0.69	41	68	3	22	70.0	7.1	6.4	11	6.4	17	13	400	223
40.00	ZV322S_KS703_0400 ME	3000	6000	≤24	0.55	41	68	3	22	70.0	7.1	6.4	11	6.4	17	13	400	223
40.00	ZV322S_KS703_0400 MEL	3000	6000	≤32	0.55	41	68	3	22	70.0	7.1	6.4	11	6.4	17	13	400	223
50.00	ZV322S_KS703_0500 ME	3200	6000	≤24	0.44	41	68	3	22	70.0	7.1	6.4	11	6.4	17	13	400	223
50.00	ZV322S_KS703_0500 MEL	3200	6000	≤32	0.44	41	68	3	22	70.0	7.1	6.4	11	6.4	17	13	400	223
70.00	ZV322S_KS703_0700 ME	3500	6000	≤24	0.31	41	68	3	22	70.0	7.1	6.4	11	6.4	17	13	400	223
70.00	ZV322S_KS703_0700 MEL	3500	6000	≤32	0.31	41	68	3	22	70.0	7.1	6.4	11	6.4	17	13	400	223
80.00	ZV322S_KS703_0800 ME	4000	6000	≤24	0.28	41	68	3	22	70.0	7.1	6.4	11	6.4	17	13	400	223
80.00	ZV322S_KS703_0800 MEL	4000	6000	≤32	0.28	41	68	3	22	70.0	7.1	6.4	11	6.4	17	13	400	223
100.0	ZV322S_KS703_1000 ME	4000	6000	≤24	0.22	41	68	3	22	70.0	7.1	6.4	11	6.4	17	13	400	223
100.0	ZV322S_KS703_1000 MEL	4000	6000	≤32	0.22	41	68	3	22	70.0	7.1	6.4	11	6.4	17	13	400	223
140.0	ZV322S_KS703_1400 ME	4000	6000	≤24	0.16	41	68	3	22	70.0	7.1	6.4	11	6.4	17	13	400	223
140.0	ZV322S_KS703_1400 MEL	4000	6000	≤32	0.16	41	68	3	22	70.0	7.1	6.4	11	6.4	17	13	400	223
200.0	ZV322S_KS703_2000 ME	4000	6000	≤24	0.11	41	68	3	22	70.0	7.1	6.4	11	6.4	17	13	400	223
200.0	ZV322S_KS703_2000 MEL	4000	6000	≤32	0.11	41	68	3	22	70.0	7.1	6.4	11	6.4	17	13	400	223

i	Type	n_{1maxDB}	n_{1maxZB}	d_{MW}	$v_{f2maxZB}$	Δs	C_{lin}	m_n	z	d_0	$F_{f2N,S}$	$F_{f2N,E}$	F_{f2accS}	F_{f2accE}	$F_{f2NOT,S}$	$F_{f2NOT,E}$	M_{2accS}	M_{2accE}
		[rpm]	[rpm]	[mm]	[m/s]	[μm]	[N/ μm]	[mm]		[mm]	[kN]	[kN]	[kN]	[kN]	[kN]	[kN]	[Nm]	[Nm]
ZV4KS7 ($F_{f2acc,max} = 10 \text{ kN}$)																		
6.000	ZV418S_KS702_0060 ME	2100	4500	≤32	3.00	44	64	4	18	76.4	6.3	6.3	10	6.7	16	13	400	256
6.000	ZV418S_KS702_0060 MEL	2100	4500	≤38	3.00	44	65	4	18	76.4	6.3	6.3	10	6.7	16	13	400	256
8.000	ZV418S_KS702_0080 ME	2500	5000	≤32	2.50	44	65	4	18	76.4	6.5	6.5	10	6.7	16	13	400	256
8.000	ZV418S_KS702_0080 MEL	2500	5000	≤38	2.50	44	65	4	18	76.4	6.5	6.5	10	6.7	16	13	400	256
10.00	ZV418S_KS702_0100 ME	2800	6000	≤32	2.40	44	65	4	18	76.4	6.5	6.5	10	6.7	16	13	400	256
10.00	ZV418S_KS702_0100 MEL	2800	6000	≤38	2.40	44	66	4	18	76.4	6.5	6.5	10	6.7	16	13	400	256
14.00	ZV418S_KS702_0140 ME	3000	6000	≤32	1.71	44	66	4	18	76.4	6.5	6.5	10	6.7	16	13	400	256
14.00	ZV418S_KS702_0140 MEL	3000	6000	≤38	1.71	44	66	4	18	76.4	6.5	6.5	10	6.7	16	13	400	256
20.00	ZV418S_KS702_0200 ME	3200	6000	≤32	1.20	44	66	4	18	76.4	6.5	6.5	10	6.7	16	13	400	256
20.00	ZV418S_KS702_0200 MEL	3200	6000	≤38	1.20	44	66	4	18	76.4	6.5	6.5	10	6.7	16	13	400	256
24.00	ZV418S_KS703_0240 ME	3000	6000	≤24	1.00	44	66	4	18	76.4	6.3	6.3	10	6.7	16	13	400	256
24.00	ZV418S_KS703_0240 MEL	3000	6000	≤32	1.00	44	66	4	18	76.4	6.3	6.3	10	6.7	16	13	400	256
32.00	ZV418S_KS703_0320 ME	3000	6000	≤24	0.75	44	66	4	18	76.4	6.5	6.5	10	6.7	16	13	400	256
32.00	ZV418S_KS703_0320 MEL	3000	6000	≤32	0.75	44	66	4	18	76.4	6.5	6.5	10	6.7	16	13	400	256
40.00	ZV418S_KS703_0400 ME	3000	6000	≤24	0.60	44	66	4	18	76.4	6.5	6.5	10	6.7	16	13	400	256
40.00	ZV418S_KS703_0400 MEL	3000	6000	≤32	0.60	44	66	4	18	76.4	6.5	6.5	10	6.7	16	13	400	256
50.00	ZV418S_KS703_0500 ME	3200	6000	≤24	0.48	44	66	4	18	76.4	6.5	6.5	10	6.7	16	13	400	256
50.00	ZV418S_KS703_0500 MEL	3200	6000	≤32	0.48	44	66	4	18	76.4	6.5	6.5	10	6.7	16	13	400	256
70.00	ZV418S_KS703_0700 ME	3500	6000	≤24	0.34	44	66	4	18	76.4	6.5	6.5	10	6.7	16	13	400	256
70.00	ZV418S_KS703_0700 MEL	3500	6000	≤32	0.34	44	66	4	18	76.4	6.5	6.5	10	6.7	16	13	400	256
80.00	ZV418S_KS703_0800 ME	4000	6000	≤24	0.30	44	66	4	18	76.4	6.5	6.5	10	6.7	16	13	400	256
80.00	ZV418S_KS703_0800 MEL	4000	6000	≤32	0.30	44	66	4	18	76.4	6.5	6.5	10	6.7	16	13	400	256
100.0	ZV418S_KS703_1000 ME	4000	6000	≤24	0.24	44	66	4	18	76.4	6.5	6.5	10	6.7	16	13	400	256
100.0	ZV418S_KS703_1000 MEL	4000	6000	≤32	0.24	44	66	4	18	76.4	6.5	6.5	10	6.7	16	13	400	256
140.0	ZV418S_KS703_1400 ME	4000	6000	≤24	0.17	44	66	4	18	76.4	6.5	6.5	10	6.7	16	13	400	256
140.0	ZV418S_KS703_1400 MEL	4000	6000	≤32	0.17	44	66	4	18	76.4	6.5	6.5	10	6.7	16	13	400	256
200.0	ZV418S_KS703_2000 ME	4000	6000	≤24	0.12	44	66	4	18	76.4	6.5	6.5	10	6.7	16	13	400	256
200.0	ZV418S_KS703_2000 MEL	4000	6000	≤32	0.12	44	66	4	18	76.4	6.5	6.5	10	6.7	16	13	400	256

10.3 Dimensional drawings

In this chapter, you can find the dimensions of the rack and pinion drives with motor adapter.

Dimension a_z in the tables of dimensions applies to STOBBER gear racks. In general: $a_z = \frac{1}{2} d_0 + h_0 + x \cdot m_n$

The pinion of the rack and pinion drive is helical (left-hand 19° 31' 42"). The pinion gearing quality is 6.

Dimensions can exceed the specifications of ISO 2768-mK due to casting tolerances or accumulation of individual tolerances.

We reserve the right to make dimensional changes due to ongoing technical development.

You can download 3D models of our standard drives at <https://configurator.stoeber.de/en-US/>.

10.3.1 Pinion position E

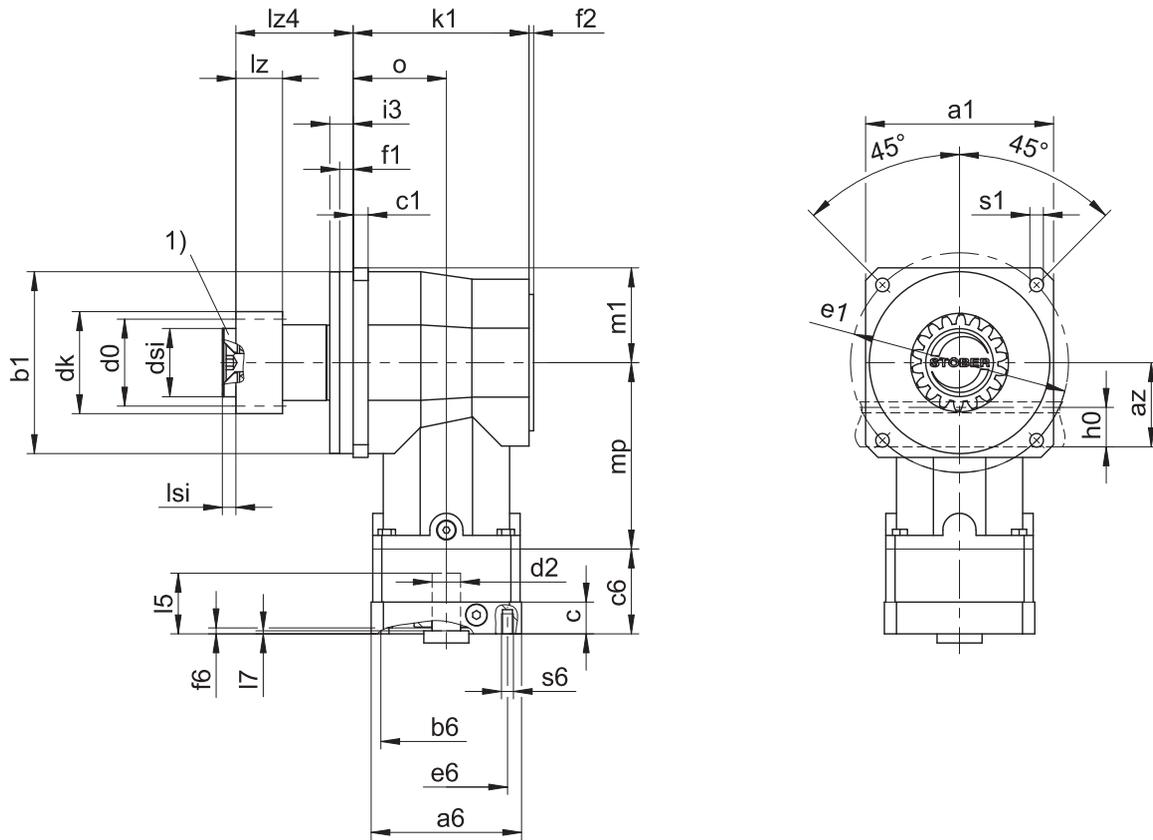

1) Axial locking (optional)

Output dimensions

Type	mn	a1	az	Øb1	c1	Ød0	Ødk	Ødsi	Øe1	f1	f2	h0	i3	k1	lz	lz4	lsi	mp	m1	o	Øs1	x
ZV220SEKS402_	2	101	44.02	95 _{h6}	10	42.44	47.90	30	120	8	3	22	14.0	101	26	54.5	6	104.0	50.5	53	6.6	0.4
ZV220SEKS403_	2	101	44.02	95 _{h6}	10	42.44	47.90	30	120	8	3	22	14.0	101	26	54.5	6	144.0	50.5	53	6.6	0.4
ZV225SEKS502_	2	125	49.33	120 _{h6}	10	53.05	58.52	45	145	9	3	22	15.5	117	26	78.0	8	123.0	62.5	62	9.0	0.4
ZV225SEKS503_	2	125	49.33	120 _{h6}	10	53.05	58.52	45	145	9	3	22	15.5	117	26	78.0	8	172.0	62.5	62	9.0	0.4
ZV318SEKS502_	3	125	55.55	120 _{h6}	10	57.30	65.01	45	145	9	3	26	15.5	117	31	78.0	8	123.0	62.5	62	9.0	0.3
ZV318SEKS503_	3	125	55.55	120 _{h6}	10	57.30	65.01	45	145	9	3	26	15.5	117	31	78.0	8	172.0	62.5	62	9.0	0.3
ZV322SEKS702_	3	155	62.21	150 _{h6}	15	70.03	78.35	55	180	10	3	26	20.0	145	31	107.5	10	151.0	77.5	78	11.0	0.4
ZV322SEKS703_	3	155	62.21	150 _{h6}	15	70.03	78.35	55	180	10	3	26	20.0	145	31	107.5	10	205.5	77.5	78	11.0	0.4
ZV418SEKS702_	4	155	74.40	150 _{h6}	15	76.40	86.77	55	180	10	3	35	20.0	145	41	107.5	10	151.0	77.5	78	11.0	0.3
ZV418SEKS703_	4	155	74.40	150 _{h6}	15	76.40	86.77	55	180	10	3	35	20.0	145	41	107.5	10	205.5	77.5	78	11.0	0.3

Example dimensions for the motor connection

Type	Øb6	Øe6	Ød2max	l5	□a6	c	c6	f6	l7	s6
ZV_KS402_ME	60 ^{H7}	75	19	40	75	18	51.5	3.5	3.0	M5
ZV_KS403_ME	40 ^{H7}	63	14	30	55	15	32.0	3.5	3.0	M5
ZV_KS502_ME	95 ^{H7}	115	24	42	100	21	56.0	4.0	3.0	M8
ZV_KS503_ME	60 ^{H7}	75	19	40	75	18	51.5	3.5	3.0	M5
ZV_KS702_ME	110 ^{H7}	130	32	50	120	24	67.5	4.0	3.5	M8
ZV_KS703_ME	95 ^{H7}	115	24	42	100	21	56.0	4.0	3.0	M8

In the table above, you will find example dimensions for the motor connection for the ME motor adapter.

Note that when dimension c is lengthened, dimensions c6 and l5 are also lengthened accordingly.

You will find additional motor connection dimensions for motor adapters ME and MEL in our STOEGER Configurator at <https://configurator.stoeber.de/en-US/>. Here, you can directly download a 3D model of your drive.

10.3.2 Pinion position S

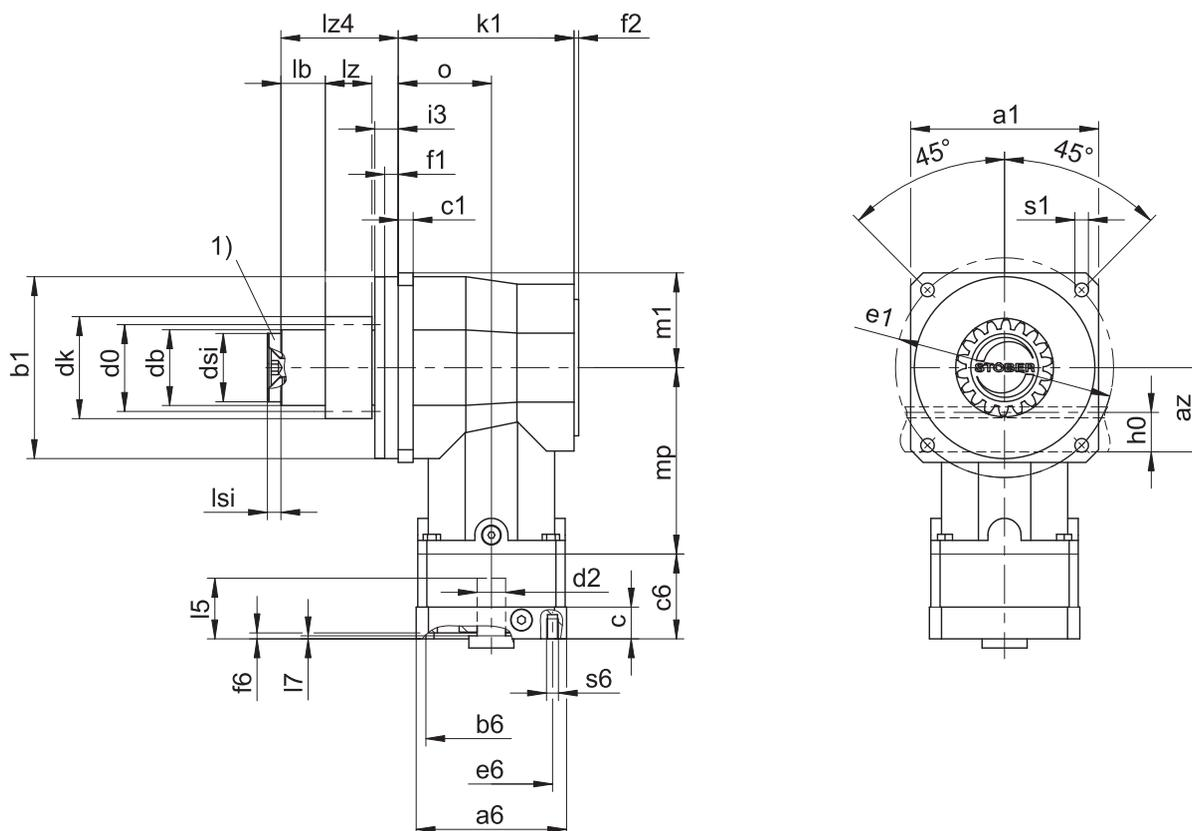

1) Axial locking (optional)

Output dimensions

Type	mn	a1	az	Øb1	c1	Ød0	Ødb	Ødk	Ødsi	Øe1	f1	f2	h0	i3	k1	lb	lz	lz4	lsi	mp	m1	o	Øs1	x
ZV220SSKS402_	2	101	44.02	95 _{h6}	10	42.44	38	47.90	30	120	8	3	22	14.0	101	12.5	26	54.5	6	104.0	50.5	53	6.6	0.4
ZV220SSKS403_	2	101	44.02	95 _{h6}	10	42.44	38	47.90	30	120	8	3	22	14.0	101	12.5	26	54.5	6	144.0	50.5	53	6.6	0.4
ZV225SSKS502_	2	125	49.33	120 _{h6}	10	53.05	50	58.52	45	145	9	3	22	15.5	117	34.5	26	78.0	8	123.0	62.5	62	9.0	0.4
ZV225SSKS503_	2	125	49.33	120 _{h6}	10	53.05	50	58.52	45	145	9	3	22	15.5	117	34.5	26	78.0	8	172.0	62.5	62	9.0	0.4
ZV318SSKS502_	3	125	55.55	120 _{h6}	10	57.30	50	65.01	45	145	9	3	26	15.5	117	29.5	31	78.0	8	123.0	62.5	62	9.0	0.3
ZV318SSKS503_	3	125	55.55	120 _{h6}	10	57.30	50	65.01	45	145	9	3	26	15.5	117	29.5	31	78.0	8	172.0	62.5	62	9.0	0.3
ZV322SSKS702_	3	155	62.21	150 _{h6}	15	70.03	62	78.35	55	180	10	3	26	20.0	145	53.5	31	107.5	10	151.0	77.5	78	11.0	0.4
ZV322SSKS703_	3	155	62.21	150 _{h6}	15	70.03	62	78.35	55	180	10	3	26	20.0	145	53.5	31	107.5	10	205.5	77.5	78	11.0	0.4
ZV418SSKS702_	4	155	74.40	150 _{h6}	15	76.40	62	86.77	55	180	10	3	35	20.0	145	43.5	41	107.5	10	151.0	77.5	78	11.0	0.3
ZV418SSKS703_	4	155	74.40	150 _{h6}	15	76.40	62	86.77	55	180	10	3	35	20.0	145	43.5	41	107.5	10	205.5	77.5	78	11.0	0.3

Example dimensions for the motor connection

Type	Øb6	Øe6	Ød2max	l5	□a6	c	c6	f6	l7	s6
ZV_KS402_ME	60 ^{H7}	75	19	40	75	18	51.5	3.5	3.0	M5
ZV_KS403_ME	40 ^{H7}	63	14	30	55	15	32.0	3.5	3.0	M5
ZV_KS502_ME	95 ^{H7}	115	24	42	100	21	56.0	4.0	3.0	M8
ZV_KS503_ME	60 ^{H7}	75	19	40	75	18	51.5	3.5	3.0	M5
ZV_KS702_ME	110 ^{H7}	130	32	50	120	24	67.5	4.0	3.5	M8
ZV_KS703_ME	95 ^{H7}	115	24	42	100	21	56.0	4.0	3.0	M8

In the table above, you will find example dimensions for the motor connection for the ME motor adapter.

Note that when dimension c is lengthened, dimensions c6 and l5 are also lengthened accordingly.

You will find additional motor connection dimensions for motor adapters ME and MEL in our STOEBER Configurator at <https://configurator.stoeber.de/en-US/>. Here, you can directly download a 3D model of your drive.

10.3.3 Oil expansion tank

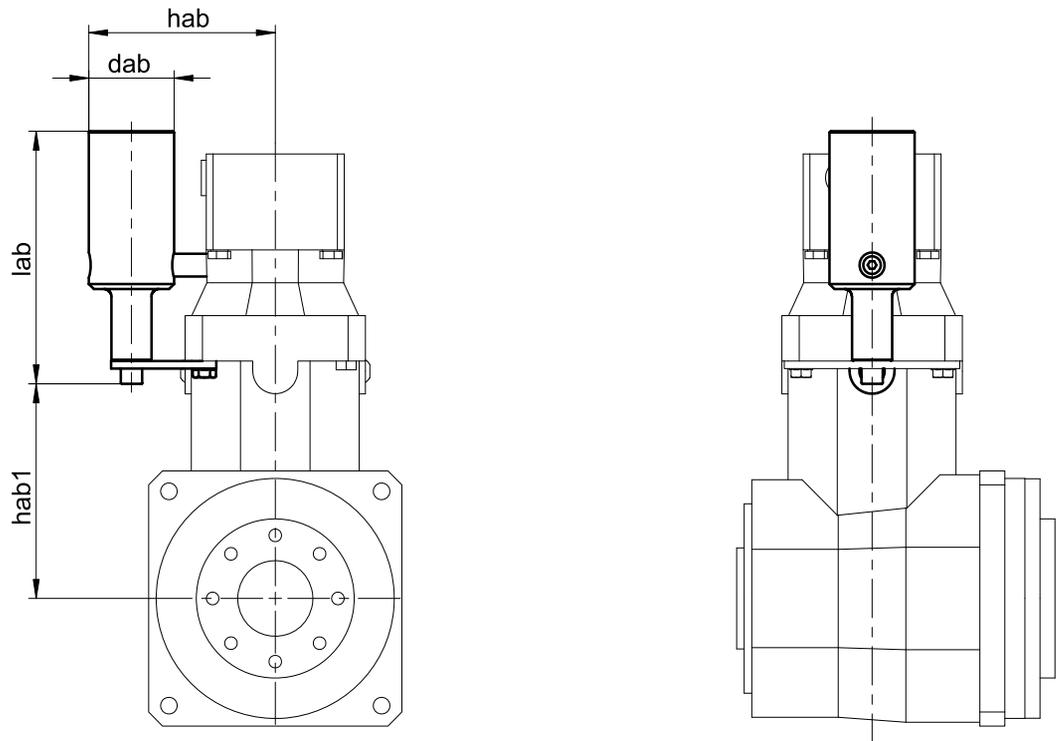

Dimensions

Type	dab	lab	hab	hab1
ZV_KS403_	34	100	74.5	85
ZV_KS503_	39	122	92.0	105
ZV_KS703_	49	134	109.5	132

More information can be found in the chapter [\[▶ 10.6.4\]](#)

10.4 Type designation

In this chapter, you can find an explanation of the type designation with the associated options.

Additional ordering information not included in the type designation can be found at the end of the chapter.

Example code

Z	V	2	20	S	S	KS	4	0	2	P	F	0080	ME
---	---	---	----	---	---	----	---	---	---	---	---	------	----

Explanation

Code	Designation	Design
Z	Type	Rack and pinion drive
V	Design	Plug-on pinion
2	Normal module	$m_n = 2$ mm (example)
20	Number of teeth	$z = 20$ (example)
S	Toothing	Helical (left-hand 19° 31' 42")
E	Pinion position	Shaft end
S		Shaft shoulder
KS	Type	Right-angle servo gear unit
4	Size	4 (example)
0	Generation	Generation 0
2	Stages	Two-stage
3		Three-stage
P	Shaft	Solid shaft with feather key
F	Housing	Standard
0080	Transmission ratio ($i \times 10$)	$i = 8$ (example)
ME	Motor adapter	Motor adapter with EasyAdapt coupling
MEL		Motor adapter with EasyAdapt coupling for large motors

To complete the type designation, also specify the following in your order:

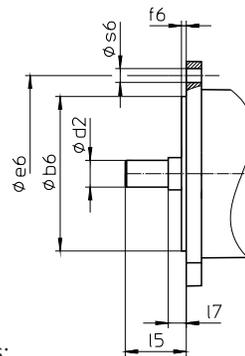

- Motor type or motor dimensions:

To choose a suitable motor connection, use the STOBBER Configurator at

<https://configurator.stoeber.de/en-US/> and choose your motor or the dimensions of the motor connection.

- Mounting position, see the chapter [▶ 10.5.5]
- The position of locking screw access, see the chapter [▶ 10.5.7]
- Radial shaft seal rings at the output, made of NBR or FKM (optional), see the chapter [▶ 10.6.3]
- Attachment of oil expansion tank (optional) on gear unit side 1 or 2 (required without exception for three-stage gear units in mounting position EL5), see the chapter [▶ 10.6.4]
- Axial locking (optional), see the chapter [▶ 10.3]

In this product catalog, you will find all the information about rack and pinion drives with a motor adapter.

All input options available upon request are listed in the chapter [▶ 10.5.1].

10.4.1 Nameplate

An example gear unit nameplate is explained in the figure below.

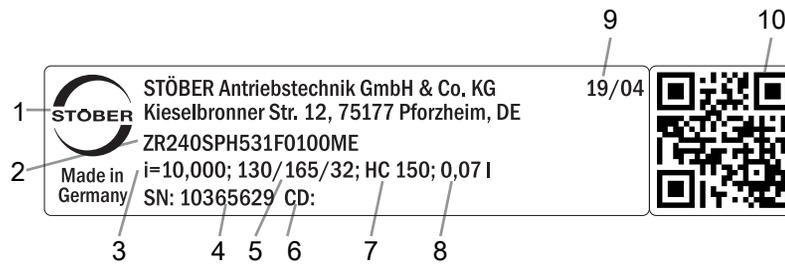

Code	Designation
1	Name of manufacturer
2	Type designation
3	Gear ratio of the gear unit
4	Serial number of the gear unit
5	Dimensions of the motor adapter (pilot/bolt circle/motor shaft diameter)
6	Customer-specific data
7	Lubricant specification
8	Lubricant fill volume
9	Date of manufacture (year/calendar week)
10	QR code (link to product information)

10.4.1.1 Supporting documents

You can view or download supporting documents for the product by reading off the serial number on the nameplate of the product and entering it at the following address online:

<https://id.stober.com>

Alternatively, you can use a suitable mobile device to scan in the QR code on the nameplate of the product in order to be linked to the supporting documents.

10.5 Product description

10.5.1 Input options

In this chapter, you will find all available input options:

ME motor adapter

EZ synchronous servo motor



Catalog ID 443137_en

Catalog ID 443286_en

The corresponding catalogs can be found at <http://www.stober.de/en/downloads/>

Enter the ID of the catalog in the Search term field.

10.5.2 Motor adapter with EasyAdapt coupling (ME/MEL)

In this chapter, you will find a description of the EasyAdapt coupling.

Properties:

- Fast and easy motor attachment
- One-piece, rugged clamp coupling with expanding function
- Lowest mass moments of inertia for the highest dynamics
- Balanced for smooth running without vibration, even at high speeds
- Large selection of motor shaft diameters and lengths
- Error-free, thanks to exact centering of the motor
- For reduced backlash, the motor shaft bearing must have an axially backlash-free design



Fig. 1: EasyAdapt coupling

10.5.3 Gear rack

The gear rack used must have a right-hand design (19° 31' 42"); the load capacity must not be exceeded.

When using a STOBBER gear rack, please also observe the project configuration in the chapter [▶ 13.6](#).

10.5.4 Installation conditions

The specified torques and forces only apply when gear units are fastened on the machine side using screws of strength class 10.9. In addition, the gear housings must be adjusted at the pilot. The machine-side fit must be H7.

10.5.5 Mounting positions

The following table shows the standard mounting positions.

The numbers identify the gear unit sides. The mounting position is defined by the gear side facing downwards.

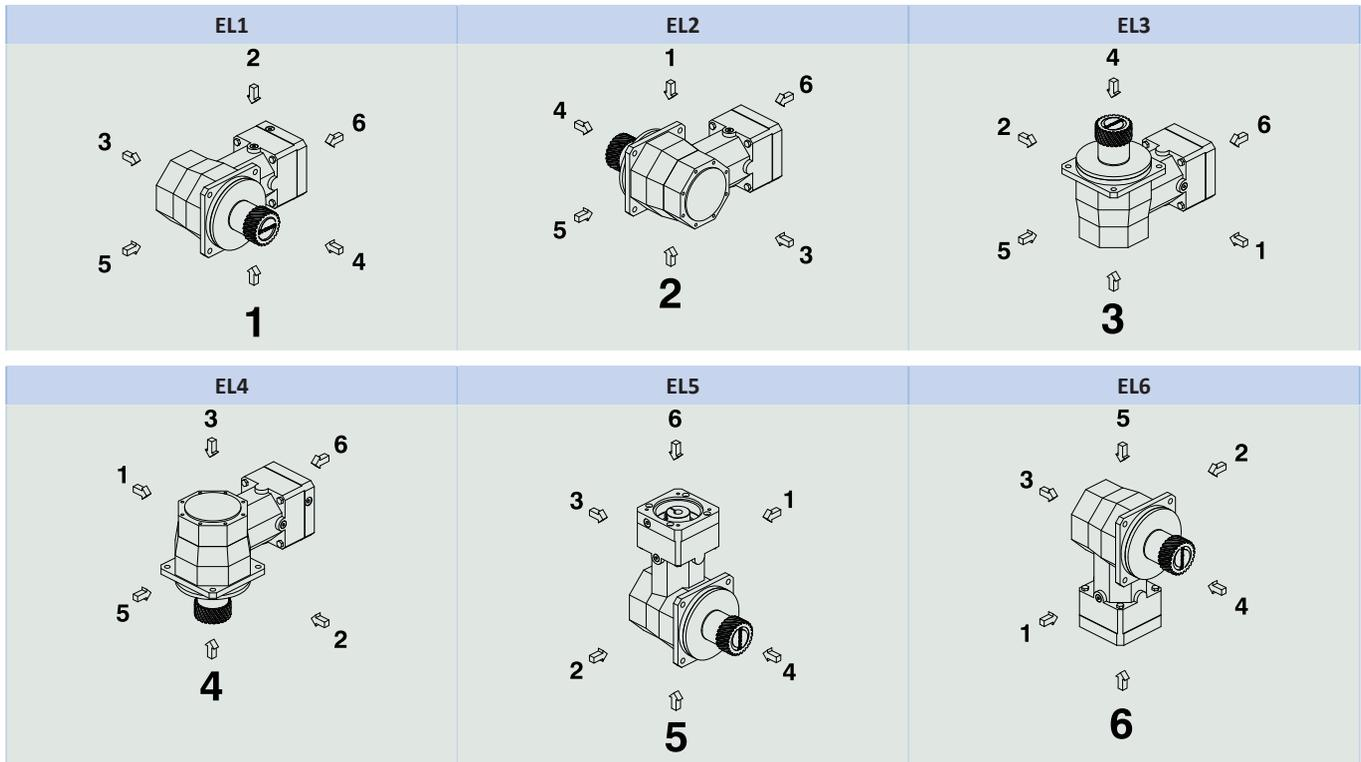

Since the lubricant filling volume of the gear unit depends on the mounting position, the mounting position must be specified when ordering.

10.5.6 Lubricants

STOBER fills the gear units with the amount and type of lubricant specified on the nameplate. The filling volume and the structure of the gear units depend on the mounting position.

Only install the gear units in the intended mounting position! Reposition the gear units only after consulting STOBER. Otherwise, STOBER assumes no liability for the gear units.

You will receive lubricants for use in the food industry upon request.

10.5.6.1 Rack and pinion drive lubrication

Ensure permanent lubrication with the lubricants recommended in the chapter [\[▶ 13.5.1\]](#).

10.5.7 Position of locking screw access

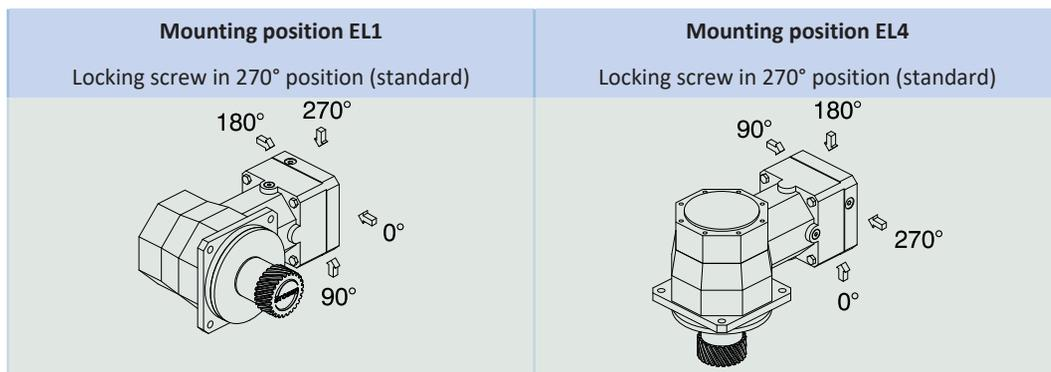

Indicate variations for your gear unit in the order.

Note that the access hole for the locking screw also rotates when the gear unit is rotated to another mounting position.

10.5.8 Other product features

Feature	Value
Max. permitted gear unit temperature (on the surface of the gear unit)	≤ 90 °C
Paint	Black RAL 9005
(ATEX) Directive 2014/34/EU (optional)	Not suitable.
Protection class: ¹	
Planetary gear unit	IP65
Pinion/gear rack	IPXX

10.5.9 Direction of rotation

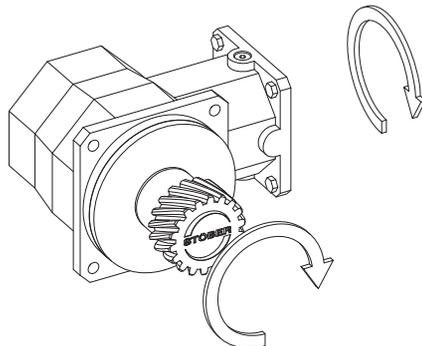

The pictures show mounting position EL1.

10.6 Project configuration

Project your drives using our SERVOSOFT designing software. Download SERVOSOFT free of charge after registration at <https://www.stoeber.de/en/services/info-servosoft/>.

It is the most convenient and reliable method of drive selection, as the entire torque/speed curve of the application is displayed and evaluated here in the curve of the geared motor.

In this chapter, only limit values for specific operating points can be taken into consideration for manual drive selection.

The formula symbols for values actually present in the application are marked with *.

An explanation of the formula symbols can be found in the chapter [▶ 14.1](#).

¹Observe the protection class of all the components.

10.6.1 Drive selection

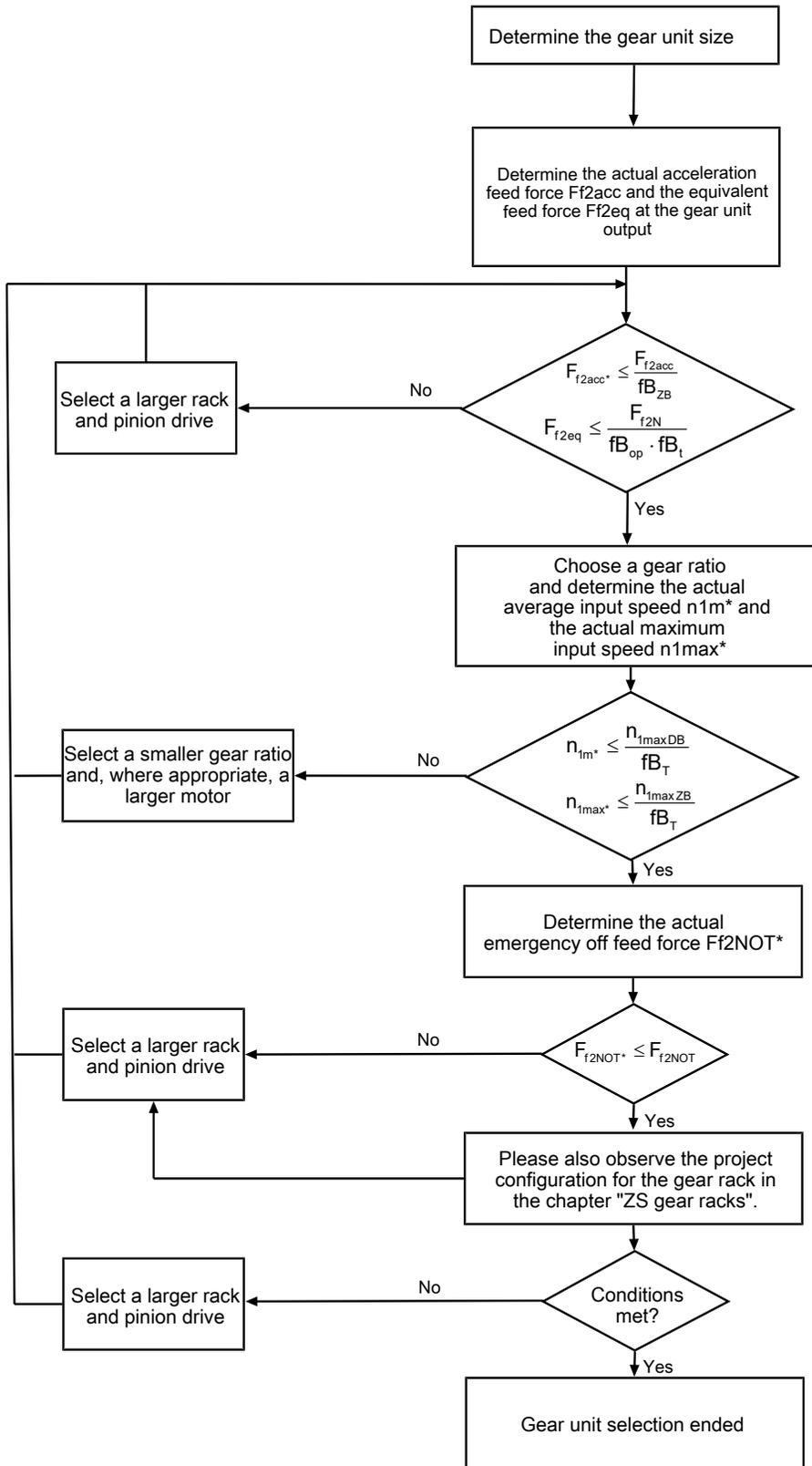

Refer to the selection tables for the values for i , n_{1maxDB} , n_{1maxZB} , F_{f2acc} , F_{f2N} and F_{f2NOT} . The forces depend on the pinion position (E or S). The speeds are partially dependent on the mounting position.

The values for fb_T , fb_{op} , fb_t and fb_{ZB} can be found in the corresponding tables in this chapter.

Example of cyclic operation

The following calculations are based on a representation of the power taken from the output based in accordance with the following example:

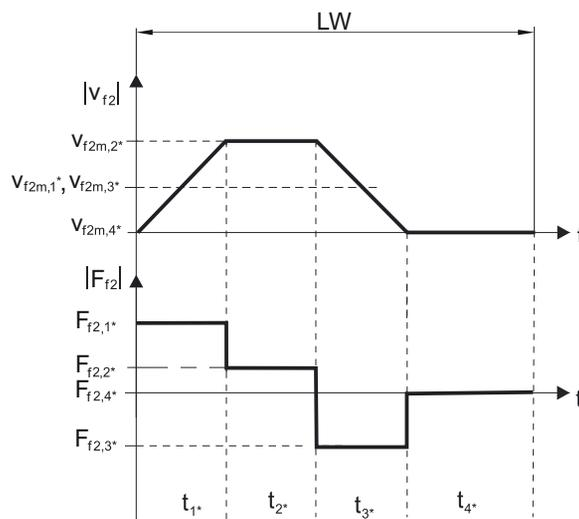

Calculation of the actual maximum acceleration feed force

$$F_{f2acc*} = m \cdot a^* + F_{L*}$$

Calculation of the actual average input speed

$$n_{1m*} = \frac{v_{f2m*} \cdot i}{d_0 \cdot \pi}$$

$$v_{f2m*} = \frac{|v_{f2m,1*}| \cdot t_{1*} + \dots + |v_{f2m,n*}| \cdot t_{n*}}{t_{1*} + \dots + t_{n*}}$$

If $t_{1*} + \dots + t_{3*} \geq 6$ min, determine v_{2m*} without the rest phase t_{4*} .

The values for the ratio i can be found in the selection tables.

Calculation of the actual emergency off feed force

$$F_{f2NOT*} = m \cdot a_{NOT*} + F_{L*}$$

Calculation of the actual equivalent feed force

$$F_{f2eq*} = \sqrt[3]{\frac{|v_{f2m,1*}| \cdot t_{1*} \cdot |F_{f2,1*}|^3 + \dots + |v_{f2m,n*}| \cdot t_{n*} \cdot |F_{f2,n*}|^3}{|v_{f2m,1*}| \cdot t_{1*} + \dots + |v_{f2m,n*}| \cdot t_{n*}}}$$

Operating factors

Operating mode	fB_{op}
Uniform continuous operation	1.00
Cyclic operation	1.00
Reversing load cyclic operation	1.00
Run time	fB_t
Daily runtime ≤ 8 h	1.00
Daily runtime ≤ 16 h	1.15
Daily runtime ≤ 24 h	1.20
Cyclic operation	fB_{ZB}
≤ 1000 load changes/hour (LW/h)	1.00
> 1000 load changes/hour (LW/h)	1.15

Temperature		f_{B_T}
Motor cooling	Surrounding temperature	
Motor with forced ventilation	$\leq 20\text{ °C}$	0.9
	$\leq 30\text{ °C}$	1.0
	$\leq 40\text{ °C}$	1.15
Motor with convection cooling	$\leq 20\text{ °C}$	1.0
	$\leq 30\text{ °C}$	1.1
	$\leq 40\text{ °C}$	1.25

Notes

- The maximum permitted gear unit temperature (see the "Other product features" chapter) must not be exceeded, as that could result in damage.
- For braking from full speed (for example, when the power fails or when setting up the machine), note the permitted gear unit feed forces (F_{f2acc} , F_{f2NOT}) in the selection tables.

10.6.2 Permitted breakdown torques at the gear unit input

For a horizontal mounting position of the motor, verify that the permitted breakdown torque at the gear unit input is not exceeded before installation on a STOBER gear unit. You can find information for how to do that in this chapter.

Calculate the actual breakdown torque as follows:

$$M_{1k^*} = F_{1k^*} \cdot l_{sp} \leq M_{1k}$$

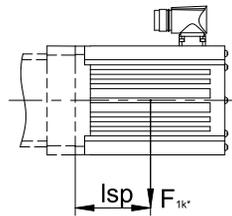

Type	M_{1k} [Nm]
KS402_ME	20
KS403_ME	10
KS502_ME	40
KS503_ME	20
KS702_ME	80
KS703_ME	40

The values also apply to the MEL motor adapter.

10.6.3 Recommendation for radial shaft seal rings

For a duty cycle > 60% and higher surrounding temperatures, we recommend radial shaft seal rings made of FKM at the output.

Properties:

- Excellent temperature resistance
- High chemical stability
- Very good resistance to aging
- Excellent resistance in oils and greases
- For use in the food, beverage and pharmaceutical industries

Leak-proofness

Our gear units are equipped with high-quality radial shaft seal rings and checked for leaks. However, a leak cannot be fully ruled out over the length of use of a gear unit. If you use a gear unit with goods incompatible with the lubricant, you must take measures to prevent direct contact with the gear unit lubricant in case of a leak.

10.6.4 Oil expansion tank

The gear units have a higher fill level in mounting position EL5. The oil expansion tank prevents oil from escaping out of the gear unit.

Notes

- Three-stage KS gear units in mounting position EL5 can be used only in combination with an oil expansion tank!
- It is not possible to use an oil expansion tank if the plug connector and oil expansion tank are on the same side!
- Please specify the attachment side (gear unit side 1 or 2) in the order.
- Note that mounting an oil expansion tank is not possible with every motor adapter (collision between motor adapter and oil expansion tank).

10.7 Additional documentation

Additional documentation related to the product can be found at

<http://www.stoeber.de/en/downloads/>

Enter the ID of the documentation in the Search term field.

Documentation	ID
Operating manual gear units, geared motors KS	443362_en
Operating manual gear racks	443392_en

11 ZVKL rack and pinion drives

Table of contents

11.1 Overview	156
11.2 Selection tables	157
11.3 Dimensional drawings	158
11.3.1 Pinion position E	158
11.3.2 Pinion position S	159
11.4 Type designation	160
11.4.1 Nameplate	161
11.5 Product description	161
11.5.1 Input options	161
11.5.2 Square motor adapter with backlash-free plug-in coupling (MQ)	162
11.5.3 Gear rack	162
11.5.4 Installation conditions	162
11.5.5 Gear unit sides	162
11.5.6 Lubricants	162
11.5.7 Position of locking screw access	163
11.5.8 Other product features	163
11.5.9 Direction of rotation	163
11.6 Project configuration	163
11.6.1 Drive selection	164
11.6.2 Permitted breakdown torques at the gear unit input	166
11.7 Additional documentation	166

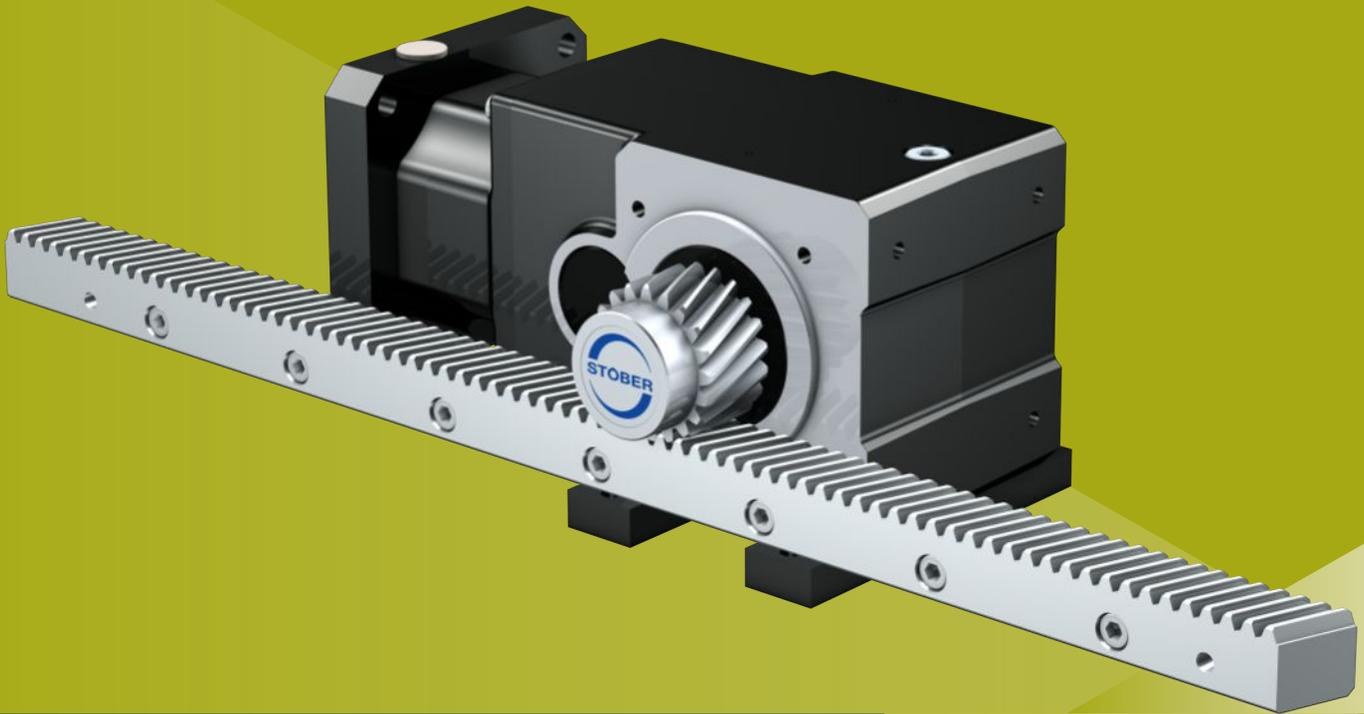

11

Rack and pinion drives

ZVKL

11.1 Overview

Compact right-angle gear units with plug-on pinion

Features

- Power density ★★★★★
- Linear clearance ★★★★★
- Price category €
- Smooth operation ★★★★★
- Linear rigidity ★★★★★
- Mass moment of inertia ★★★★★
- Ready-to-install drive solution ✓
- Pinion gearing quality 6 (DIN 3962) ✓
- Helical gearing ✓
- Case-hardened and smoothed ✓

Key ★☆☆☆☆ good | ★★★★★ excellent
 € Economy | €€€€€ Premium

Technical data

m_n	2 mm
z	16 – 20
F_{f2acc}	1.3 – 2.7 kN
$v_{f2maxZB}$	0.33 – 3.3 m/s
Δs	99 – 123 μm

11.2 Selection tables

The technical data specified in the selection tables applies to:

- De-energized installation
- Permanent lubrication with the lubricants recommended in the chapter on gear racks [▶ 13.5.1]
- Case-hardened pinions, helical (left-hand 19° 31' 42"), gearing quality 6
- Installation altitudes up to 1000 m above sea level
- Surrounding temperatures from 0 °C to 40 °C
- Without consideration of the thermal limiting performance
- C_{fin} : Pinion position S

For all other technical data, refer to <https://configurator.stoeber.de/en-US/>.

An explanation of the formula symbols can be found in the chapter [▶ 14.1].

i	Type	n_{1maxDB} [rpm]	n_{1maxZB} [rpm]	d_{MW} [mm]	$v_{f2maxZB}$ [m/s]	Δs [μm]	C_{fin} [N/μm]	m_n [mm]	z	d_0 [mm]	$F_{f2N,S}$ [kN]	$F_{f2N,E}$ [kN]	F_{f2accS} [kN]	F_{f2accE} [kN]	$F_{f2NOT,S}$ [kN]	$F_{f2NOT,E}$ [kN]	M_{2accS} [Nm]	M_{2accE} [Nm]
ZV2KL1 ($F_{v2acc,max} = 1,5 \text{ kN}$)																		
4.000	ZV216S_KL102_0040 MQ	3500	6000	≤16	2.67	123	4.6	2	16	34.0	0.9	0.9	1.3	1.3	1.7	1.7	22	22
8.000	ZV216S_KL102_0080 MQ	3500	6000	≤16	1.33	99	5.4	2	16	34.0	1.3	1.3	1.5	1.5	3.1	3.0	26	26
16.00	ZV216S_KL102_0160 MQ	4000	6000	≤16	0.67	99	5.5	2	16	34.0	1.5	1.5	1.5	1.5	3.1	3.0	26	26
32.00	ZV216S_KL102_0320 MQ	4000	6000	≤16	0.33	99	5.4	2	16	34.0	1.5	1.5	1.5	1.5	3.1	3.0	26	26
ZV2KL2 ($F_{v2acc,max} = 2,7 \text{ kN}$)																		
4.000	ZV220S_KL202_0040 MQ	3500	6000	≤19	3.33	123	7.5	2	20	42.4	1.5	1.4	2.3	2.3	3.9	3.9	50	50
8.000	ZV220S_KL202_0080 MQ	3500	6000	≤19	1.67	99	10	2	20	42.4	1.9	1.8	2.7	2.5	5.4	5.0	57	53
16.00	ZV220S_KL202_0160 MQ	4000	6000	≤19	0.83	99	11	2	20	42.4	2.4	2.2	2.7	2.5	5.4	5.0	57	53
32.00	ZV220S_KL202_0320 MQ	4000	6000	≤19	0.42	99	9.9	2	20	42.4	2.4	2.4	2.7	2.5	5.4	5.0	57	53

11.3 Dimensional drawings

In this chapter, you can find the dimensions of the rack and pinion drives with motor adapter.

Dimension az in the tables of dimensions applies to STÖBER gear racks. In general: $az = \frac{1}{2} d_0 + h_0 + x \cdot mn$

The pinion of the rack and pinion drive is helical (left-hand $19^\circ 31' 42''$). The pinion gearing quality is 6.

Dimensions can exceed the specifications of ISO 2768-mK due to casting tolerances or accumulation of individual tolerances.

We reserve the right to make dimensional changes due to ongoing technical development.

You can download 3D models of our standard drives at <https://configurator.stoeber.de/en-US/>.

11.3.1 Pinion position E

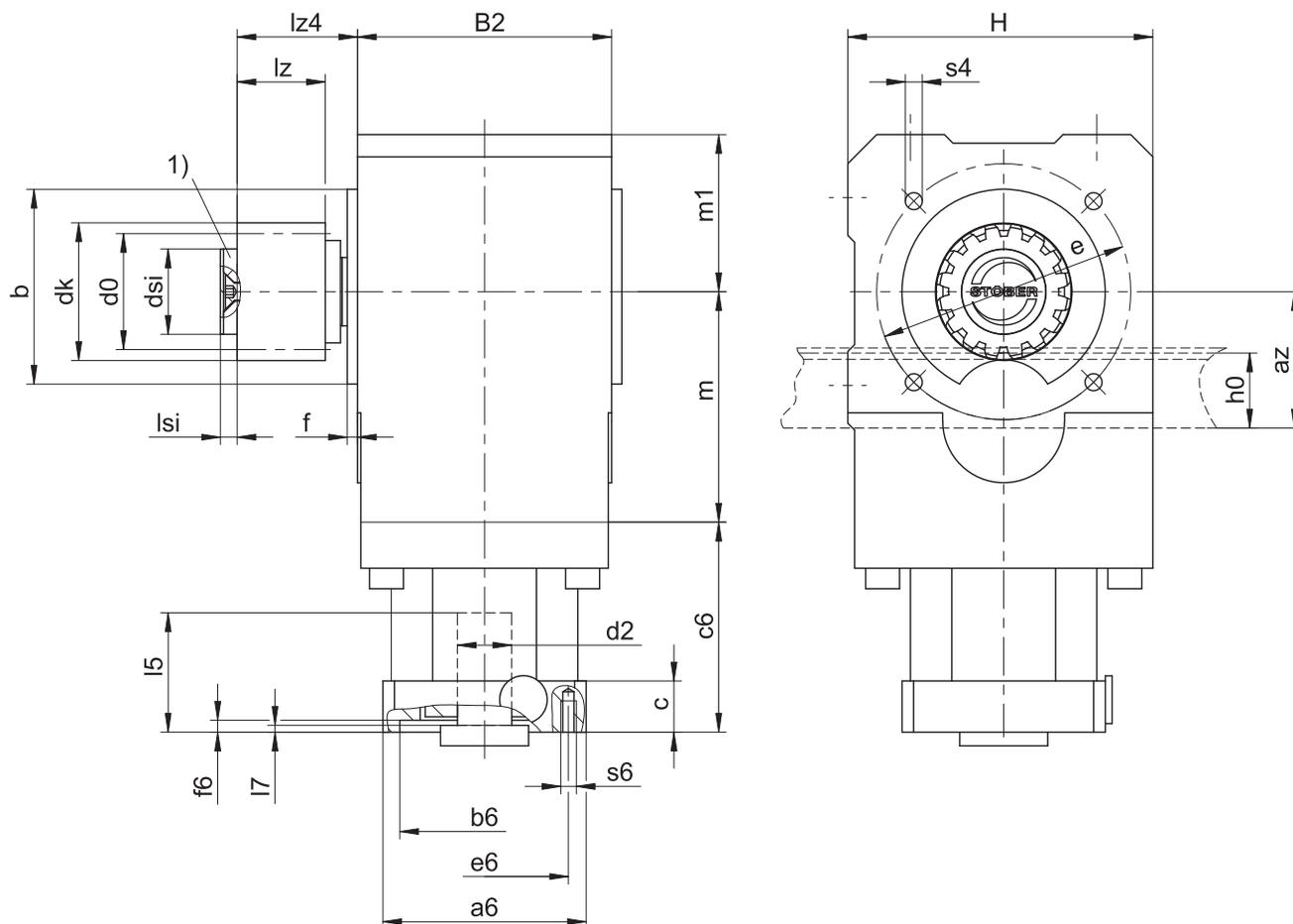

1) Axial locking (optional)

Output dimensions

Type	mn	az	$\varnothing b$	B_2	$\varnothing d_0$	$\varnothing dk$	$\varnothing dsi$	$\varnothing e$	f	h_0	H	lz	lz_4	l_{si}	m	m_1	s_4	x
ZV216SEKL1_	2	39.98	$60_{\frac{f_6}{6}}$	75	33.95	39.81	25	75	3	22	90	26	35.5	5	67.5	46	M6	0.5
ZV220SEKL2_	2	44.02	$75_{\frac{f_6}{6}}$	92	42.44	47.90	30	90	3	22	108	26	44.5	7	88.5	55	M6	0.4

Example dimensions for the motor connection

Type	$\varnothing b_6$	$\varnothing e_6$	$\varnothing d_{2max}$	l_5	$\square a_6$	c	c_6	f_6	l_7	s_6
ZV2_KL102_MQ	40^{H7}	63	16	30	55	15	61.5	3.5	3	M5
ZV2_KL202_MQ	60^{H7}	75	19	40	75	18	69.5	3.5	3	M5

In the table above, you will find example dimensions for the motor connection for the MQ motor adapter.

Note that when dimension c is lengthened, dimensions c_6 and l_5 are lengthened accordingly.

You will find additional motor connection dimensions for the MQ motor adapter in our STÖBER Configurator at <https://configurator.stoeber.de/en-US/>. Here, you can directly download a 3D model of your drive.

11.3.2 Pinion position S

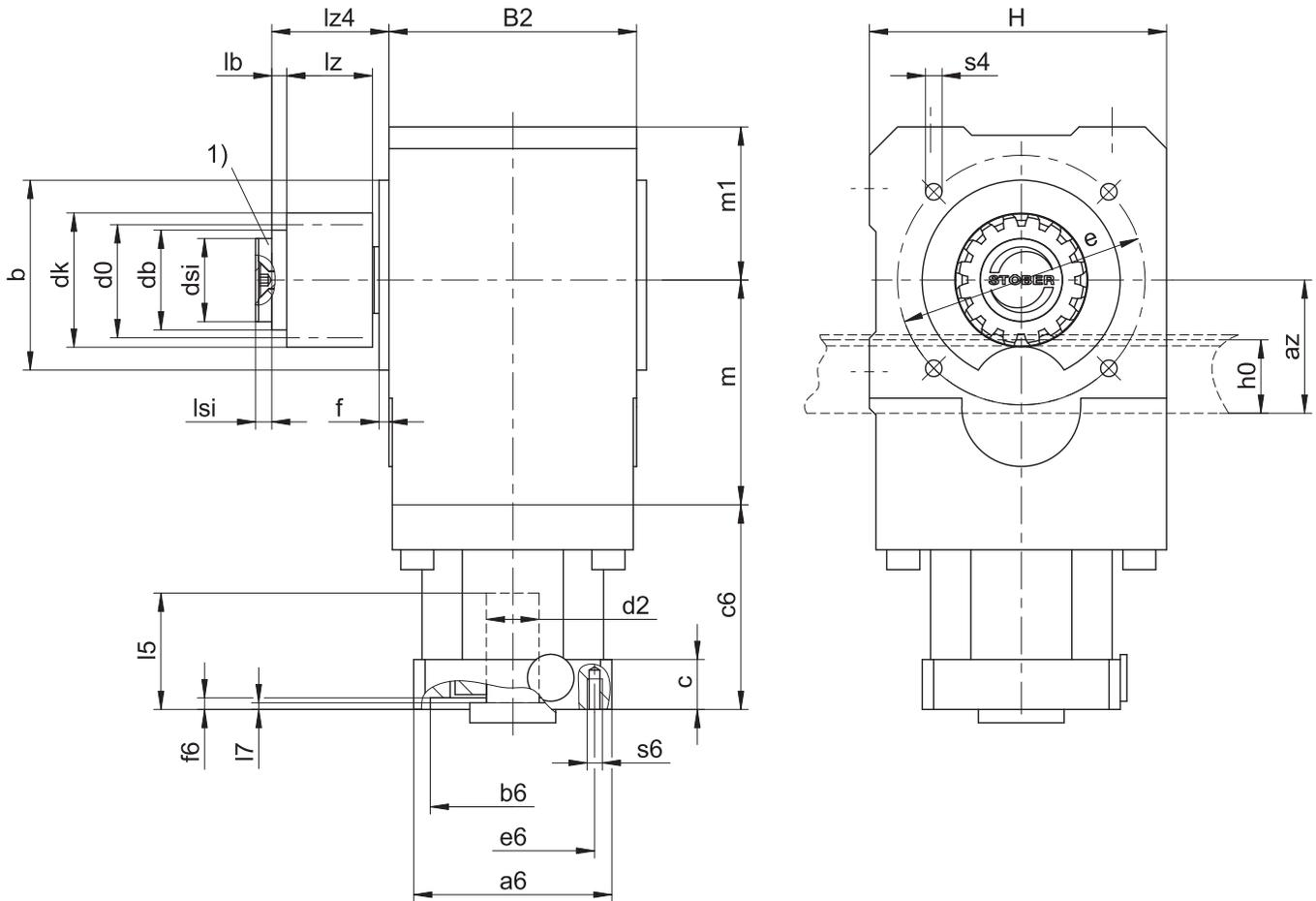

1) Axial locking (optional)

Output dimensions

Type	mn	az	Øb	B2	Ød0	Ødb	Ødk	Ødsi	Øe	f	h0	H	lb	lz	lz4	lsi	m	m1	s4	x
ZV216SSKL1_	2	39.98	60 _{js}	75	33.95	30	39.81	25	75	3	22	90	4.5	26	35.5	5	67.5	46	M6	0.5
ZV220SSKL2_	2	44.02	75 _{js}	92	42.44	38	47.90	30	90	3	22	108	12.5	26	44.5	7	88.5	55	M6	0.4

Example dimensions for the motor connection

Type	Øb6	Øe6	Ød2max	l5	□a6	c	c6	f6	l7	s6
ZV2_KL102_MQ	40 ^{H7}	63	16	30	55	15	61.5	3.5	3	M5
ZV2_KL202_MQ	60 ^{H7}	75	19	40	75	18	69.5	3.5	3	M5

In the table above, you will find example dimensions for the motor connection for the MQ motor adapter.

Note that when dimension c is lengthened, dimensions c6 and l5 are lengthened accordingly.

You will find additional motor connection dimensions for the MQ motor adapter in our STOEGER Configurator at <https://configurator.stoeber.de/en-US/>. Here, you can directly download a 3D model of your drive.

11.4 Type designation

In this chapter, you can find an explanation of the type designation with the associated options.

Additional ordering information not included in the type designation can be found at the end of the chapter.

Example code

Z	V	2	20	S	S	KL	2	0	2	P	G	0080	MQ
---	---	---	----	---	---	----	---	---	---	---	---	------	----

Explanation

Code	Designation	Design
Z	Type	Rack and pinion drive
V	Design	Plug-on pinion
2	Normal module	$m_n = 2$ mm (example)
20	Number of teeth	$z = 20$ (example)
S	Toothing	Helical (left-hand 19° 31' 42")
E	Pinion position	Shaft end
S		Shaft shoulder
KL	Type	Helical bevel gear unit
2	Size	2 (example)
0	Generation	Generation 0
2	Stages	Two-stage
P	Shaft	Solid shaft with feather key
G	Housing	Pitch circle diameter
0080	Transmission ratio ($i \times 10$)	$i = 8$ (example)
MQ	Motor adapter	Square motor adapter with backlash-free plug-in coupling

To complete the type designation, also specify the following in your order:

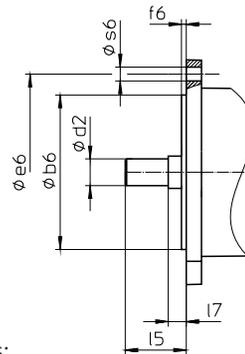

- Motor type or motor dimensions:

To choose a suitable motor connection, use the STOBBER Configurator at

<https://configurator.stoeber.de/en-US/> and choose your motor or the dimensions of the motor connection.

- Attachment of solid shaft: gear unit side 3 or 4
- Pitch circle diameter: gear unit side 3 or 4
- For the position of locking screw access, see the chapter [▶ 11.5.7](#)
- For axial locking (optional), see the chapter [▶ 11.3](#)

An explanation of the gear unit sides can be found in the chapter [▶ 11.5.5](#)

In this product catalog, you will find all the information about rack and pinion drives with a motor adapter.

All input options available upon request are listed in the chapter [▶ 11.5.1](#).

11.4.1 Nameplate

An example gear unit nameplate is explained in the figure below.

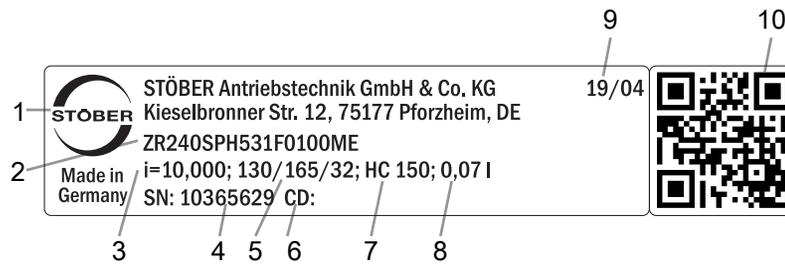

Code	Designation
1	Name of manufacturer
2	Type designation
3	Gear ratio of the gear unit
4	Serial number of the gear unit
5	Dimensions of the motor adapter (pilot/bolt circle/motor shaft diameter)
6	Customer-specific data
7	Lubricant specification
8	Lubricant fill volume
9	Date of manufacture (year/calendar week)
10	QR code (link to product information)

11.4.1.1 Supporting documents

You can view or download supporting documents for the product by reading off the serial number on the nameplate of the product and entering it at the following address online:

<https://id.stober.com>

Alternatively, you can use a suitable mobile device to scan in the QR code on the nameplate of the product in order to be linked to the supporting documents.

11.5 Product description

11.5.1 Input options

In this chapter, you will find all available input options:

MQ motor adapter



Catalog ID 443137_en

EZ synchronous servo motor



Catalog ID 443286_en

LM Lean motor



On request

The corresponding catalogs can be found at <http://www.stober.de/en/downloads/>

Enter the ID of the catalog in the Search term field.

11.5.2 Square motor adapter with backlash-free plug-in coupling (MQ)

In this chapter, you will find a description of the backlash-free plug-in coupling (jaw coupling).

Properties:

- Fast and easy motor attachment
- With integrated thermal length compensation, compensates for linear expansion of the motor shaft
- Balanced for smooth running without vibration, even at high speeds
- Large selection of motor shaft diameters and lengths
- Error-free, thanks to exact centering of the motor



Fig. 1: Backlash-free plug-in coupling

11.5.3 Gear rack

The gear rack used must have a right-hand design (19° 31' 42"); the load capacity must not be exceeded.

When using a STOBER gear rack, please also observe the project configuration in the chapter [\[▶ 13.6\]](#).

11.5.4 Installation conditions

The specified torques and forces only apply when gear units are fastened on the machine side using screws of strength class 10.9. In addition, the gear housings must be adjusted at the pilot. The machine-side fit must be H7.

11.5.5 Gear unit sides

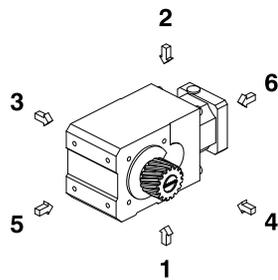

The numbers identify the gear unit sides.

11.5.6 Lubricants

STOBER fills the gear units with the amount and type of lubricant specified on the nameplate.

You will receive lubricants for use in the food industry upon request.

11.5.6.1 Rack and pinion drive lubrication

Ensure permanent lubrication with the lubricants recommended in the chapter [\[▶ 13.5.1\]](#).

11.5.7 Position of locking screw access

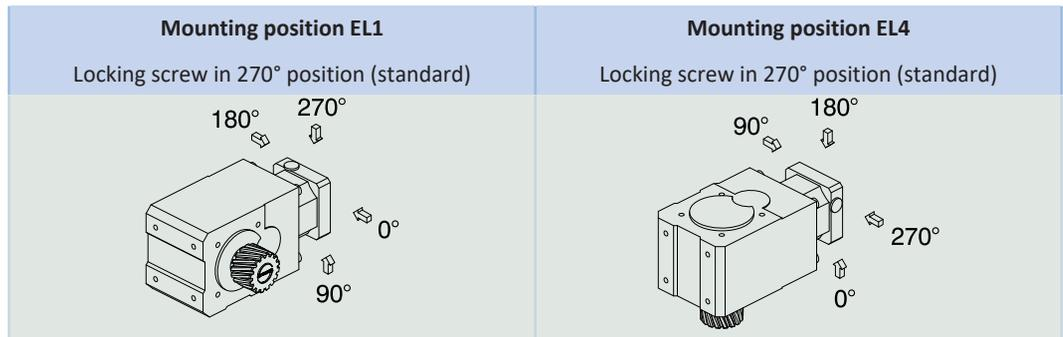

Indicate variations for your gear unit in the order.

Note that the access hole for the locking screw also rotates when the gear unit is rotated to another mounting position.

11.5.8 Other product features

Feature	Value
Max. permitted gear unit temperature (on the surface of the gear unit)	≤ 80 °C
Paint	Black RAL 9005
(ATEX) Directive 2014/34/EU (optional)	Not suitable.
Protection class: ¹	
Planetary gear unit	IP65
Pinion/gear rack	IPXX

11.5.9 Direction of rotation

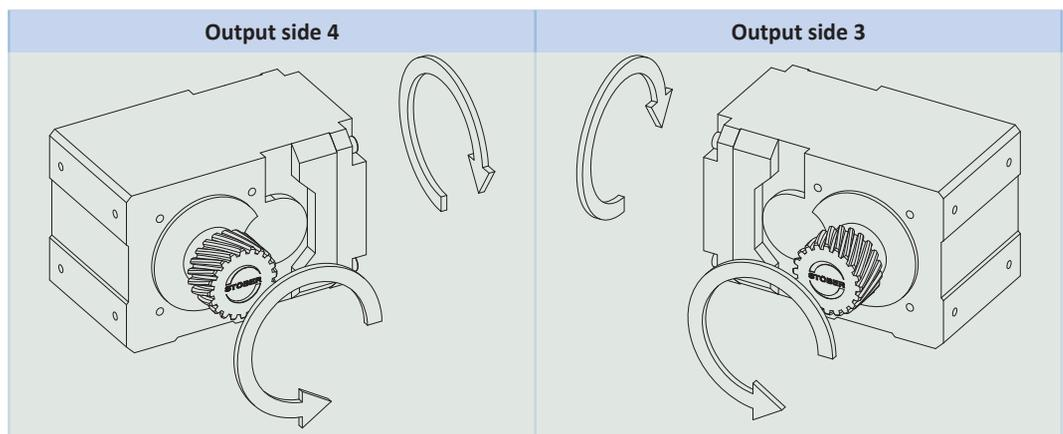

The pictures show mounting position EL1.

11.6 Project configuration

Project your drives using our SERVOSOFT designing software. Download SERVOSOFT free of charge after registration at <https://www.stoeber.de/en/services/info-servosoft/>.

It is the most convenient and reliable method of drive selection, as the entire torque/speed curve of the application is displayed and evaluated here in the curve of the geared motor.

In this chapter, only limit values for specific operating points can be taken into consideration for manual drive selection.

The formula symbols for values actually present in the application are marked with *.

An explanation of the formula symbols can be found in the chapter [▶ 14.1](#).

¹ Observe the protection class of all the components.

11.6.1 Drive selection

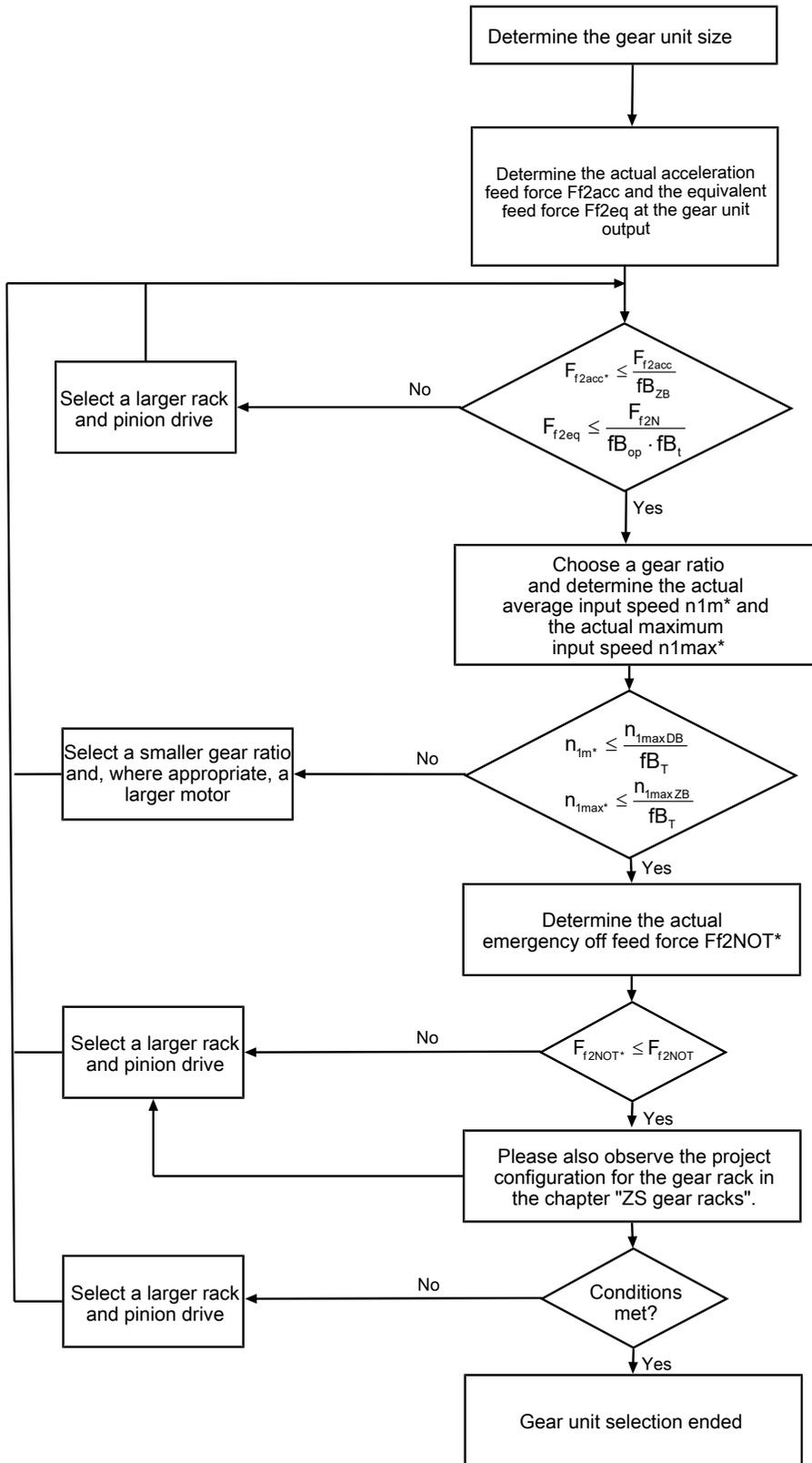

Refer to the selection tables for the values for i , n_{1maxDB} , n_{1maxZB} , F_{f2acc} , F_{f2N} and F_{f2NOT} . The forces depend on the pinion position (E or S). The speeds are partially dependent on the mounting position.

The values for fB_T , fB_{op} , fB_t and fB_{ZB} can be found in the corresponding tables in this chapter.

Example of cyclic operation

The following calculations are based on a representation of the power taken from the output based in accordance with the following example:

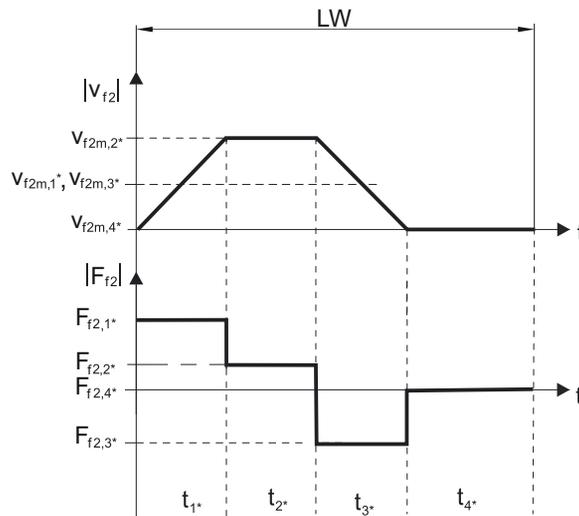

Calculation of the actual maximum acceleration feed force

$$F_{f2acc} = m \cdot a^* + F_{L^*}$$

Calculation of the actual average input speed

$$n_{1m} = \frac{v_{f2m} \cdot i}{d_0 \cdot \pi}$$

$$v_{f2m} = \frac{|v_{f2m,1}| \cdot t_1 + \dots + |v_{f2m,n}| \cdot t_n}{t_1 + \dots + t_n}$$

If $t_1 + \dots + t_3 \geq 6$ min, determine v_{2m} without the rest phase t_4 .

The values for the ratio i can be found in the selection tables.

Calculation of the actual emergency off feed force

$$F_{f2NOT} = m \cdot a_{NOT} + F_{L^*}$$

Calculation of the actual equivalent feed force

$$F_{f2eq} = \sqrt[3]{\frac{|v_{f2m,1}| \cdot t_1 \cdot |F_{f2,1}|^3 + \dots + |v_{f2m,n}| \cdot t_n \cdot |F_{f2,n}|^3}{|v_{f2m,1}| \cdot t_1 + \dots + |v_{f2m,n}| \cdot t_n}}$$

Operating factors

Operating mode	fB_{op}
Uniform continuous operation	1.00
Cyclic operation	1.25
Reversing load cyclic operation	1.40
Run time	fB_t
Daily runtime ≤ 8 h	1.00
Daily runtime ≤ 16 h	1.15
Daily runtime ≤ 24 h	1.20
Cyclic operation	fB_{zB}
≤ 1000 load changes/hour (LW/h)	1.00
> 1000 load changes/hour (LW/h)	1.15

Temperature		f_{B_T}
Motor cooling	Surrounding temperature	
Motor with forced ventilation	$\leq 20\text{ }^\circ\text{C}$	0.9
	$\leq 30\text{ }^\circ\text{C}$	1.0
	$\leq 40\text{ }^\circ\text{C}$	1.15
Motor with convection cooling	$\leq 20\text{ }^\circ\text{C}$	1.0
	$\leq 30\text{ }^\circ\text{C}$	1.1
	$\leq 40\text{ }^\circ\text{C}$	1.25

Notes

- The maximum permitted gear unit temperature (see the "Other product features" chapter) must not be exceeded, as that could result in damage.
- For braking from full speed (for example, when the power fails or when setting up the machine), note the permitted gear unit feed forces (F_{f2acc} , F_{f2NOT}) in the selection tables.

11.6.2 Permitted breakdown torques at the gear unit input

For a horizontal mounting position of the motor, verify that the permitted breakdown torque at the gear unit input is not exceeded before installation on a STOEBER gear unit. You can find information for how to do that in this chapter.

Calculate the actual breakdown torque as follows:

$$M_{1k^*} = F_{1k^*} \cdot l_{sp} \leq M_{1k}$$

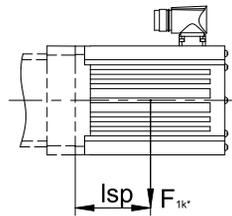

Type	M_{1k} [Nm]
KL1_MQ	15
KL2_MQ	20

11.7 Additional documentation

Additional documentation related to the product can be found at

<http://www.stoeber.de/en/downloads/>

Enter the ID of the documentation in the Search term field.

Documentation	ID
Operating manual gear units, geared motors KL	443363_en
Operating manual gear racks	443392_en

12 ZVK rack and pinion drives

Table of contents

12.1 Overview	168
12.2 Selection tables	169
12.3 Dimensional drawings	179
12.3.1 Pinion position E	180
12.3.2 Pinion position S	182
12.4 Type designation	184
12.4.1 Nameplate	185
12.5 Product description	185
12.5.1 Input options	185
12.5.2 Motor adapter with EasyAdapt coupling (ME)	186
12.5.3 Square motor adapter with backlash-free plug-in coupling (MQ)	186
12.5.4 Gear rack	186
12.5.5 Installation conditions	187
12.5.6 Mounting positions	187
12.5.7 Lubricants	187
12.5.8 Position of locking screw access	188
12.5.9 Other product features	188
12.5.10 Direction of rotation	188
12.6 Project configuration	189
12.6.1 Drive selection	190
12.6.2 Permitted breakdown torques at the gear unit input	192
12.7 Additional documentation	192

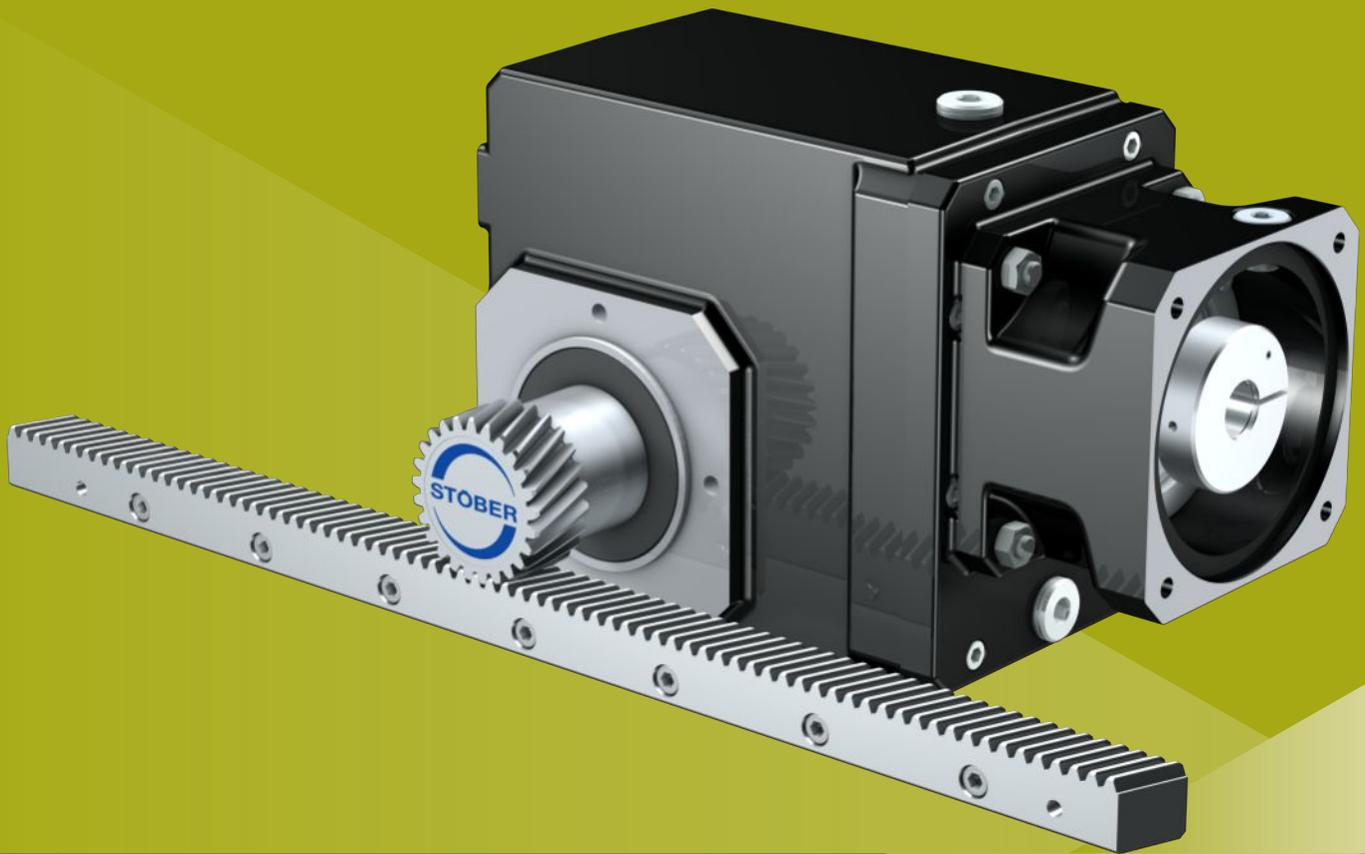

12

Rack and pinion drives

ZVK

12.1 Overview

Highly rigid right-angle gear units with plug-on pinion

Features

- Power density ★☆☆☆☆
- Linear clearance ★★☆☆☆
- Price category €
- Smooth operation ★★☆☆☆
- Linear rigidity ★☆☆☆☆
- Mass moment of inertia ★★☆☆☆
- Ready-to-install drive solution ✓
- Pinion gearing quality 6 (DIN 3962) ✓
- Helical gearing ✓
- Case-hardened and smoothed ✓

Key ★☆☆☆☆ good | ★★★★★ excellent
 € Economy | €€€€€ Premium

Technical data

m_n	2 – 4 mm
z	18 – 25
F_{f2acc}	2.7 – 15 kN
$v_{f2maxZB}$	0.06 – 3.8 m/s
Δs	12 – 111 μ m

12.2 Selection tables

The technical data specified in the selection tables applies to:

- De-energized installation
- Permanent lubrication with the lubricants recommended in the chapter on gear racks ▶ 13.5.1
- Case-hardened pinions, helical (left-hand 19° 31' 42"), gearing quality 6
- Installation altitudes up to 1000 m above sea level
- Surrounding temperatures from 0 °C to 40 °C
- Without consideration of the thermal limiting performance
- C_{lin} : Pinion position S

For all other technical data, refer to <https://configurator.stoeber.de/en-US/>.

An explanation of the formula symbols can be found in the chapter ▶ 14.1].

i	Type	n_{1maxDB}		n_{1maxZV}	d_{MW}	$v_{f2maxZB}$	Δs	Δs_{redII}	Δs_{redI}	C_{lin}	m_n	z	d_0	$F_{f2N,S}$	$F_{f2N,E}$	F_{f2accS}	F_{f2accE}	$F_{f2NOT,S}$	$F_{f2NOT,E}$	M_{2accS}	M_{2accE}
		<small>EL1,2</small> [rpm]	<small>EL3,4,5,6</small> [rpm]																		
ZV2K1 ($F_{v2acc,max} = 4,9 \text{ kN}$)																					
4.000	ZV220S_K102_0040 ME10	3300	2800	5000	≤19	2.78	74	37	–	17	2	20	42.4	3.1	3.1	4.4	3.2	5.5	5.5	93	68
4.000	ZV220S_K102_0040 ME20	3300	2800	5000	≤24	2.78	74	37	–	17	2	20	42.4	3.1	3.1	4.4	3.2	5.5	5.5	93	68
5.568	ZV220S_K102_0056 ME10	3300	2800	5000	≤19	2.00	74	37	–	17	2	20	42.4	3.4	3.2	4.9	3.2	7.6	6.4	105	68
5.568	ZV220S_K102_0056 ME20	3300	2800	5000	≤24	2.00	74	37	–	17	2	20	42.4	3.4	3.2	4.9	3.2	7.6	6.4	105	68
6.000	ZV220S_K102_0060 ME10	3300	2800	5000	≤19	1.85	74	37	–	17	2	20	42.4	3.5	3.2	4.9	3.2	8.2	6.4	105	68
6.000	ZV220S_K102_0060 ME20	3300	2800	5000	≤24	1.85	74	37	–	17	2	20	42.4	3.5	3.2	4.9	3.2	8.2	6.4	105	68
6.644	ZV220S_K102_0066 ME10	3600	3300	5500	≤19	1.84	74	37	–	17	2	20	42.4	3.6	3.2	4.9	3.2	9.1	6.4	105	68
6.644	ZV220S_K102_0066 ME20	3600	3300	5500	≤24	1.84	74	37	–	17	2	20	42.4	3.6	3.2	4.9	3.2	9.1	6.4	105	68
8.309	ZV220S_K102_0083 ME10	3600	3300	5500	≤19	1.47	74	37	–	17	2	20	42.4	3.9	3.2	4.9	3.2	9.9	6.4	105	68
8.309	ZV220S_K102_0083 ME20	3600	3300	5500	≤24	1.47	74	37	–	17	2	20	42.4	3.9	3.2	4.9	3.2	9.9	6.4	105	68
9.249	ZV220S_K102_0092 ME10	3600	3300	5500	≤19	1.32	74	37	–	17	2	20	42.4	4.1	3.2	4.9	3.2	9.9	6.4	105	68
9.249	ZV220S_K102_0092 ME20	3600	3300	5500	≤24	1.32	74	37	–	17	2	20	42.4	4.1	3.2	4.9	3.2	9.9	6.4	105	68
10.14	ZV220S_K102_0100 ME10	4000	3800	6000	≤19	1.32	74	37	–	17	2	20	42.4	4.2	3.2	4.9	3.2	9.9	6.4	105	68
10.14	ZV220S_K102_0100 ME20	3700	3700	6000	≤24	1.32	74	37	–	17	2	20	42.4	4.2	3.2	4.9	3.2	9.9	6.4	105	68
11.57	ZV220S_K102_0115 ME10	3600	3300	5500	≤19	1.06	74	37	–	17	2	20	42.4	4.4	3.2	4.9	3.2	9.9	6.4	105	68
11.57	ZV220S_K102_0115 ME20	3600	3300	5500	≤24	1.06	74	37	–	17	2	20	42.4	4.4	3.2	4.9	3.2	9.9	6.4	105	68
12.62	ZV220S_K102_0125 ME10	4000	3800	6000	≤19	1.06	74	37	–	17	2	20	42.4	4.5	3.2	4.9	3.2	9.9	6.4	105	68
12.62	ZV220S_K102_0125 ME20	3700	3700	6000	≤24	1.06	74	37	–	17	2	20	42.4	4.5	3.2	4.9	3.2	9.9	6.4	105	68
14.11	ZV220S_K102_0140 ME10	4000	3800	6000	≤19	0.95	74	37	–	17	2	20	42.4	4.7	3.2	4.9	3.2	9.9	6.4	105	68
14.11	ZV220S_K102_0140 ME20	3700	3700	6000	≤24	0.95	74	37	–	17	2	20	42.4	4.7	3.2	4.9	3.2	9.9	6.4	105	68
16.71	ZV220S_K102_0165 ME10	4000	4000	7000	≤19	0.93	74	37	–	17	2	20	42.4	4.9	3.2	4.9	3.2	9.9	6.4	105	68
16.71	ZV220S_K102_0165 ME20	3700	3700	6000	≤24	0.80	74	37	–	17	2	20	42.4	4.9	3.2	4.9	3.2	9.9	6.4	105	68
17.56	ZV220S_K102_0175 ME10	4000	3800	6000	≤19	0.76	74	37	–	17	2	20	42.4	4.9	3.2	4.9	3.2	9.9	6.4	105	68
17.56	ZV220S_K102_0175 ME20	3700	3700	6000	≤24	0.76	74	37	–	17	2	20	42.4	4.9	3.2	4.9	3.2	9.9	6.4	105	68
20.15	ZV220S_K102_0200 ME10	4000	4000	7000	≤19	0.77	74	37	–	17	2	20	42.4	4.9	3.2	4.9	3.2	9.9	6.4	105	68
20.15	ZV220S_K102_0200 ME20	3700	3700	6000	≤24	0.66	74	37	–	17	2	20	42.4	4.9	3.2	4.9	3.2	9.9	6.4	105	68
23.27	ZV220S_K102_0230 ME10	4000	4000	7000	≤19	0.67	74	37	–	17	2	20	42.4	4.9	3.2	4.9	3.2	9.9	6.4	105	68
23.27	ZV220S_K102_0230 ME20	3700	3700	6000	≤24	0.57	74	37	–	17	2	20	42.4	4.9	3.2	4.9	3.2	9.9	6.4	105	68
25.22	ZV220S_K102_0250 ME10	4000	4000	7000	≤19	0.62	74	37	–	17	2	20	42.4	4.5	3.2	4.9	3.2	9.1	6.4	105	68
25.22	ZV220S_K102_0250 ME20	3700	3700	6000	≤24	0.53	74	37	–	17	2	20	42.4	4.5	3.2	4.9	3.2	9.1	6.4	105	68
28.05	ZV220S_K102_0280 ME10	4000	4000	7000	≤19	0.56	74	37	–	17	2	20	42.4	4.9	3.2	4.9	3.2	9.9	6.4	105	68
28.05	ZV220S_K102_0280 ME20	3700	3700	6000	≤24	0.48	74	37	–	17	2	20	42.4	4.9	3.2	4.9	3.2	9.9	6.4	105	68
33.71	ZV220S_K102_0340 ME10	4000	4000	7000	≤19	0.46	74	37	–	17	2	20	42.4	3.4	3.2	4.1	3.2	6.9	6.4	88	68
35.11	ZV220S_K102_0350 ME10	4000	4000	7000	≤19	0.44	74	37	–	17	2	20	42.4	4.9	3.2	4.9	3.2	9.9	6.4	105	68
35.11	ZV220S_K102_0350 ME20	3700	3700	6000	≤24	0.38	74	37	–	17	2	20	42.4	4.9	3.2	4.9	3.2	9.9	6.4	105	68
40.30	ZV220S_K102_0400 ME10	4000	4000	7000	≤19	0.39	74	37	–	17	2	20	42.4	2.9	2.9	3.5	3.2	5.8	5.8	74	68
46.92	ZV220S_K102_0470 ME10	4000	4000	7000	≤19	0.33	74	37	–	17	2	20	42.4	4.8	3.2	4.9	3.2	9.6	6.4	105	68
50.31	ZV220S_K102_0500 ME10	4000	4000	7000	≤19	0.31	74	37	–	17	2	20	42.4	2.4	2.4	2.8	2.8	4.7	4.7	60	60
56.10	ZV220S_K102_0560 ME10	4000	4000	7000	≤19	0.28	74	37	–	17	2	20	42.4	4.0	3.2	4.8	3.2	8.1	6.4	103	68
70.03	ZV220S_K102_0700 ME10	4000	4000	7000	≤19	0.22	74	37	–	17	2	20	42.4	3.3	3.2	3.9	3.2	6.6	6.4	83	68
ZV2K2 ($F_{v2acc,max} = 8,3 \text{ kN}$)																					
4.000	ZV225S_K202_0040 ME20	3000	2600	4500	≤32	3.13	77	39	12	23	2	25	53.1	4.4	4.4	6.6	5.2	11	10	174	138
4.000	ZV225S_K202_0040 ME30	3000	2600	4500	≤38	3.13	77	39	12	23	2	25	53.1	4.4	4.4	6.6	5.2	11	10	174	138
4.364	ZV225S_K202_0044 ME10	3000	2600	4500	≤19	2.86	77	39	12	23	2	25	53.1	3.8	3.8	3.8	3.8	4.8	4.8	102	102
4.364	ZV225S_K202_0044 ME20	3000	2600	4500	≤32	2.86	77	39	12	23	2	25	53.1	4.5	4.5	6.8	5.2	12	10	180	138
4.364	ZV225S_K202_0044 ME30	3000	2600	4500	≤38	2.86	77	39	12	24	2	25	53.1	4.5	4.5	6.8	5.2	12	10	180	138
5.177	ZV225S_K202_0052 ME20	3000	2600	4500	≤32	2.41	77	39	12	23	2	25	53.1	4.8	4.8	7.2	5.2	14	10	190	138
5.177	ZV225S_K202_0052 ME30	3000	2600	4500	≤38	2.41	77	39	12	24	2	25	53.1	4.8	4.8	7.2	5.2	14	10	190	138

12.2 Selection tables 12 ZVK rack and pinion drives

i	Type	n _{1maxDB}		n _{1maxZV}	d _{MW}	v _{ZmaxZB}	Δs	Δs _{redII}	Δs _{redI}	C _{lin}	m _n	z	d ₀	F _{ZN,S}	F _{ZN,E}	F _{ZaccS}	F _{ZaccE}	F _{ZNOT,S}	F _{ZNOT,E}	M _{2accS}	M _{2accE}
		EL1,2 [rpm]	EL3,4,5,6 [rpm]																		
ZV2K2 (F _{v2acc,max} = 8,3 kN)																					
6.000	ZV225S_K202_0060 ME10	3000	2600	4500	≤19	2.08	77	39	12	23	2	25	53.1	5.0	5.0	5.3	5.2	6.6	6.6	140	138
6.000	ZV225S_K202_0060 ME20	3000	2600	4500	≤32	2.08	77	39	12	24	2	25	53.1	5.0	5.0	7.5	5.2	15	10	200	138
6.000	ZV225S_K202_0060 ME30	3000	2600	4500	≤38	2.08	77	39	12	24	2	25	53.1	5.0	5.0	7.5	5.2	15	10	200	138
6.683	ZV225S_K202_0067 ME10	3500	3100	5000	≤19	2.08	77	39	12	23	2	25	53.1	5.1	5.1	5.9	5.2	7.3	7.3	156	138
6.683	ZV225S_K202_0067 ME20	3500	3100	5000	≤32	2.08	77	39	12	24	2	25	53.1	5.2	5.2	7.8	5.2	15	10	207	138
6.683	ZV225S_K202_0067 ME30	3500	3100	5000	≤38	2.08	77	39	12	24	2	25	53.1	5.2	5.2	7.8	5.2	15	10	207	138
7.118	ZV225S_K202_0071 ME20	3000	2600	4500	≤32	1.76	77	39	12	24	2	25	53.1	5.3	5.2	8.0	5.2	15	10	211	138
7.118	ZV225S_K202_0071 ME30	3000	2600	4500	≤38	1.76	77	39	12	24	2	25	53.1	5.3	5.2	8.0	5.2	15	10	211	138
8.397	ZV225S_K202_0084 ME10	3500	3100	5000	≤19	1.65	77	39	12	23	2	25	53.1	5.6	5.2	7.4	5.2	9.2	9.2	196	138
8.397	ZV225S_K202_0084 ME20	3500	3100	5000	≤32	1.65	77	39	12	24	2	25	53.1	5.6	5.2	8.3	5.2	15	10	220	138
8.397	ZV225S_K202_0084 ME30	3500	3100	5000	≤38	1.65	77	39	12	24	2	25	53.1	5.6	5.2	8.3	5.2	15	10	220	138
9.190	ZV225S_K202_0092 ME10	3500	3100	5000	≤19	1.51	77	39	12	23	2	25	53.1	5.8	5.2	8.1	5.2	10	10	214	138
9.190	ZV225S_K202_0092 ME20	3500	3100	5000	≤32	1.51	77	39	12	24	2	25	53.1	5.8	5.2	8.3	5.2	15	10	220	138
9.190	ZV225S_K202_0092 ME30	3500	3100	5000	≤38	1.51	77	39	12	24	2	25	53.1	5.8	5.2	8.3	5.2	15	10	220	138
10.07	ZV225S_K202_0100 ME10	3900	3500	5500	≤19	1.52	77	39	12	23	2	25	53.1	5.9	5.2	8.3	5.2	11	10	220	138
10.07	ZV225S_K202_0100 ME20	3700	3500	5500	≤32	1.52	77	39	12	24	2	25	53.1	6.0	5.2	8.3	5.2	15	10	220	138
10.07	ZV225S_K202_0100 ME30	3500	3500	5000	≤38	1.38	77	39	12	24	2	25	53.1	6.0	5.2	8.3	5.2	15	10	220	138
11.55	ZV225S_K202_0115 ME10	3500	3100	5000	≤19	1.20	77	39	12	23	2	25	53.1	6.2	5.2	8.3	5.2	13	10	220	138
11.55	ZV225S_K202_0115 ME20	3500	3100	5000	≤32	1.20	77	39	12	24	2	25	53.1	6.2	5.2	8.3	5.2	15	10	220	138
11.55	ZV225S_K202_0115 ME30	3500	3100	5000	≤38	1.20	77	39	12	24	2	25	53.1	6.2	5.2	8.3	5.2	15	10	220	138
12.71	ZV225S_K202_0125 ME10	3900	3500	5500	≤19	1.20	77	39	12	24	2	25	53.1	6.3	5.2	8.3	5.2	14	10	220	138
12.71	ZV225S_K202_0125 ME20	3700	3500	5500	≤32	1.20	77	39	12	24	2	25	53.1	6.4	5.2	8.3	5.2	15	10	220	138
12.71	ZV225S_K202_0125 ME30	3500	3500	5000	≤38	1.09	77	39	12	24	2	25	53.1	6.4	5.2	8.3	5.2	15	10	220	138
13.85	ZV225S_K202_0140 ME10	3900	3500	5500	≤19	1.10	77	39	12	24	2	25	53.1	6.6	5.2	8.3	5.2	15	10	220	138
13.85	ZV225S_K202_0140 ME20	3700	3500	5500	≤32	1.10	77	39	12	24	2	25	53.1	6.6	5.2	8.3	5.2	15	10	220	138
13.85	ZV225S_K202_0140 ME30	3500	3500	5000	≤38	1.00	77	39	12	24	2	25	53.1	6.6	5.2	8.3	5.2	15	10	220	138
16.86	ZV225S_K202_0170 ME10	4000	3900	6500	≤19	1.07	77	39	12	24	2	25	53.1	6.7	5.2	8.3	5.2	15	10	220	138
16.86	ZV225S_K202_0170 ME20	3700	3700	6000	≤32	0.99	77	39	12	24	2	25	53.1	7.1	5.2	8.3	5.2	15	10	220	138
16.86	ZV225S_K202_0170 ME30	3500	3500	5000	≤38	0.82	77	39	12	24	2	25	53.1	7.1	5.2	8.3	5.2	15	10	220	138
17.47	ZV225S_K202_0175 ME10	3900	3500	5500	≤19	0.88	77	39	12	24	2	25	53.1	7.2	5.2	8.3	5.2	15	10	220	138
17.47	ZV225S_K202_0175 ME20	3700	3500	5500	≤32	0.88	77	39	12	24	2	25	53.1	7.2	5.2	8.3	5.2	15	10	220	138
17.47	ZV225S_K202_0175 ME30	3500	3500	5000	≤38	0.80	77	39	12	24	2	25	53.1	7.2	5.2	8.3	5.2	15	10	220	138
20.33	ZV225S_K202_0200 ME10	4000	3900	6500	≤19	0.89	77	39	12	24	2	25	53.1	6.9	5.2	8.3	5.2	15	10	220	138
20.33	ZV225S_K202_0200 ME20	3700	3700	6000	≤24	0.82	77	39	12	24	2	25	53.1	7.5	5.2	8.3	5.2	15	10	220	138
23.18	ZV225S_K202_0230 ME10	4000	3900	6500	≤19	0.78	77	39	12	24	2	25	53.1	7.5	5.2	8.3	5.2	15	10	220	138
23.18	ZV225S_K202_0230 ME20	3700	3700	6000	≤32	0.72	77	39	12	24	2	25	53.1	7.5	5.2	8.3	5.2	15	10	220	138
23.18	ZV225S_K202_0230 ME30	3500	3500	5000	≤38	0.60	77	39	12	24	2	25	53.1	7.5	5.2	8.3	5.2	15	10	220	138
25.13	ZV225S_K202_0250 ME10	4000	3900	6500	≤19	0.72	77	39	12	24	2	25	53.1	7.1	5.2	8.3	5.2	15	10	220	138
25.13	ZV225S_K202_0250 ME20	3700	3700	6000	≤24	0.66	77	39	12	24	2	25	53.1	7.5	5.2	8.3	5.2	15	10	220	138
27.95	ZV225S_K202_0280 ME10	4000	3900	6500	≤19	0.65	77	39	12	24	2	25	53.1	7.5	5.2	8.3	5.2	15	10	220	138
27.95	ZV225S_K202_0280 ME20	3700	3700	6000	≤24	0.60	77	39	12	24	2	25	53.1	7.5	5.2	8.3	5.2	15	10	220	138
33.62	ZV225S_K202_0340 ME10	4000	3900	6500	≤19	0.54	77	39	12	24	2	25	53.1	5.8	5.2	7.0	5.2	12	10	185	138
33.62	ZV225S_K202_0340 ME20	3700	3700	6000	≤24	0.50	77	39	12	24	2	25	53.1	5.8	5.2	7.0	5.2	12	10	185	138
34.55	ZV225S_K202_0350 ME10	4000	3900	6500	≤19	0.52	77	39	12	24	2	25	53.1	7.5	5.2	8.3	5.2	15	10	220	138
34.55	ZV225S_K202_0350 ME20	3700	3700	6000	≤24	0.48	77	39	12	24	2	25	53.1	7.5	5.2	8.3	5.2	15	10	220	138
39.45	ZV225S_K203_0390 ME10	4000	3900	6500	≤19	0.46	77	46	19	24	2	25	53.1	7.5	5.2	7.6	5.2	9.5	9.5	202	138
40.39	ZV225S_K202_0400 ME10	4000	3900	6500	≤19	0.45	77	39	12	24	2	25	53.1	4.4	4.4	5.2	5.2	7.4	7.4	139	138
45.22	ZV225S_K203_0450 ME10	4000	3900	6500	≤19	0.40	77	46	19	24	2	25	53.1	7.5	5.2	8.3	5.2	11	10	220	138
46.23	ZV225S_K202_0460 ME10	4000	3900	6500	≤19	0.39	77	39	12	24	2	25	53.1	7.5	5.2	8.3	5.2	15	10	220	138
46.23	ZV225S_K202_0460 ME20	3700	3700	6000	≤24	0.36	77	39	12	24	2	25	53.1	7.5	5.2	8.3	5.2	15	10	220	138
49.76	ZV225S_K203_0500 ME10	4000	3900	6500	≤19	0.36	77	46	19	24	2	25	53.1	7.5	5.2	8.3	5.2	12	10	220	138
50.49	ZV225S_K202_0500 ME10	4000	3900	6500	≤19	0.36	77	39	12	24	2	25	53.1	3.6	3.6	4.4	4.4	6.9	6.9	116	116
54.25	ZV225S_K203_0540 ME10	4000	3900	6500	≤19	0.33	77	46	19	24	2	25	53.1	7.5	5.2	8.3	5.2	13	10	220	138
55.54	ZV225S_K202_0560 ME10	4000	3900	6500	≤19	0.33	77	39	12	24	2	25	53.1	6.0	5.2	7.2	5.2	10	10	191	138
66.03	ZV225S_K203_0660 ME10	4000	3900	6500	≤19	0.27	77	46	19	24	2	25	53.1	7.5	5.2	8.3	5.2	15	10	220	138
68.42	ZV225S_K203_0680 ME10	4000	3900	6500	≤19	0.26	77	46	19	24	2	25	53.1	7.5	5.2	8.3	5.2	15	10	220	138
69.43	ZV225S_K202_0690 ME10	4000	3900	6500	≤19	0.26	77	39	12	24	2	25	53.1	5.0	5.0	6.0	5.2	9.5	9.5	159	138
79.62	ZV225S_K203_0800 ME10	4000	3900	6500	≤19	0.23	77	46	19	24	2	25	53.1	7.5	5.2	8.3	5.2	15	10	220	138
90.79	ZV225S_K203_0910 ME10	4000	3900	6500	≤19	0.20	77	46	19	24	2	25	53.1	7.5	5.2	8.3	5.2	15	10	220	138
109.5	ZV225S_K203_1090 ME10	4000	3900	6500	≤19	0.17	77	46	19	24	2	25	53.1	7.5	5.2	8.3	5.2	15	10	220	138
135.3	ZV225S_K203_1350 ME10	4000	3900	6500	≤19	0.13	77	46	19	24	2	25	53.1	7.5	5.2	8.3	5.2	15	10	220	138
181.0	ZV225S_K203_1810 ME10	4000	3900	6500	≤19	0.10	7														

i	Type	n _{1maxDB}		n _{1maxZV}	d _{MW}	v _{f2maxZB}	Δs	Δs _{redII}	Δs _{redI}	C _{lin}	m _n	z	d ₀	F _{f2N,S}	F _{f2N,E}	F _{f2accS}	F _{f2accE}	F _{f2NOT,S}	F _{f2NOT,E}	M _{2accS}	M _{2accE}
		EL1,2 [rpm]	EL3,4,5,6 [rpm]																		
ZV3K2 (F_{v2acc,max} = 7,7 kN)																					
4.000	ZV318S_K202_0040 ME20	3000	2600	4500	≤32	3.38	83	42	12	22	3	18	57.3	4.1	4.1	6.1	5.4	10	10	174	154
4.000	ZV318S_K202_0040 ME30	3000	2600	4500	≤38	3.38	83	42	12	23	3	18	57.3	4.1	4.1	6.1	5.4	10	10	174	154
4.364	ZV318S_K202_0044 ME10	3000	2600	4500	≤19	3.09	83	42	12	22	3	18	57.3	3.5	3.5	3.5	3.5	4.4	4.4	102	102
4.364	ZV318S_K202_0044 ME20	3000	2600	4500	≤32	3.09	83	42	12	23	3	18	57.3	4.2	4.2	6.3	5.4	11	11	180	154
4.364	ZV318S_K202_0044 ME30	3000	2600	4500	≤38	3.09	83	42	12	23	3	18	57.3	4.2	4.2	6.3	5.4	11	11	180	154
5.177	ZV318S_K202_0052 ME20	3000	2600	4500	≤32	2.61	83	42	12	23	3	18	57.3	4.4	4.4	6.6	5.4	13	11	190	154
5.177	ZV318S_K202_0052 ME30	3000	2600	4500	≤38	2.61	83	42	12	23	3	18	57.3	4.4	4.4	6.6	5.4	13	11	190	154
6.000	ZV318S_K202_0060 ME10	3000	2600	4500	≤19	2.25	83	42	12	22	3	18	57.3	4.6	4.6	4.9	4.9	6.1	6.1	140	140
6.000	ZV318S_K202_0060 ME20	3000	2600	4500	≤32	2.25	83	42	12	23	3	18	57.3	4.6	4.6	7.0	5.4	14	11	200	154
6.000	ZV318S_K202_0060 ME30	3000	2600	4500	≤38	2.25	83	42	12	23	3	18	57.3	4.6	4.6	7.0	5.4	14	11	200	154
6.683	ZV318S_K202_0067 ME10	3500	3100	5000	≤19	2.24	83	42	12	22	3	18	57.3	4.7	4.7	5.4	5.4	6.8	6.8	156	154
6.683	ZV318S_K202_0067 ME20	3500	3100	5000	≤32	2.24	83	42	12	23	3	18	57.3	4.8	4.8	7.2	5.4	14	11	207	154
6.683	ZV318S_K202_0067 ME30	3500	3100	5000	≤38	2.24	83	42	12	23	3	18	57.3	4.8	4.8	7.2	5.4	14	11	207	154
7.118	ZV318S_K202_0071 ME20	3000	2600	4500	≤32	1.90	83	42	12	23	3	18	57.3	4.9	4.9	7.4	5.4	14	11	211	154
7.118	ZV318S_K202_0071 ME30	3000	2600	4500	≤38	1.90	83	42	12	23	3	18	57.3	4.9	4.9	7.4	5.4	14	11	211	154
8.397	ZV318S_K202_0084 ME10	3500	3100	5000	≤19	1.79	83	42	12	22	3	18	57.3	5.2	5.2	6.8	5.4	8.5	8.5	196	154
8.397	ZV318S_K202_0084 ME20	3500	3100	5000	≤32	1.79	83	42	12	23	3	18	57.3	5.2	5.2	7.7	5.4	14	11	220	154
8.397	ZV318S_K202_0084 ME30	3500	3100	5000	≤38	1.79	83	42	12	23	3	18	57.3	5.2	5.2	7.7	5.4	14	11	220	154
9.190	ZV318S_K202_0092 ME10	3500	3100	5000	≤19	1.63	83	42	12	23	3	18	57.3	5.4	5.4	7.5	5.4	9.3	9.3	214	154
9.190	ZV318S_K202_0092 ME20	3500	3100	5000	≤32	1.63	83	42	12	23	3	18	57.3	5.4	5.4	7.7	5.4	14	11	220	154
9.190	ZV318S_K202_0092 ME30	3500	3100	5000	≤38	1.63	83	42	12	23	3	18	57.3	5.4	5.4	7.7	5.4	14	11	220	154
10.07	ZV318S_K202_0100 ME10	3900	3500	5500	≤19	1.64	83	42	12	23	3	18	57.3	5.4	5.4	7.7	5.4	10	10	220	154
10.07	ZV318S_K202_0100 ME20	3700	3500	5500	≤32	1.64	83	42	12	23	3	18	57.3	5.5	5.4	7.7	5.4	14	11	220	154
10.07	ZV318S_K202_0100 ME30	3500	3500	5000	≤38	1.49	83	42	12	23	3	18	57.3	5.5	5.4	7.7	5.4	14	11	220	154
11.55	ZV318S_K202_0115 ME10	3500	3100	5000	≤19	1.30	83	42	12	23	3	18	57.3	5.8	5.4	7.7	5.4	12	11	220	154
11.55	ZV318S_K202_0115 ME20	3500	3100	5000	≤32	1.30	83	42	12	23	3	18	57.3	5.8	5.4	7.7	5.4	14	11	220	154
11.55	ZV318S_K202_0115 ME30	3500	3100	5000	≤38	1.30	83	42	12	23	3	18	57.3	5.8	5.4	7.7	5.4	14	11	220	154
12.71	ZV318S_K202_0125 ME10	3900	3500	5500	≤19	1.30	83	42	12	23	3	18	57.3	5.9	5.4	7.7	5.4	13	11	220	154
12.71	ZV318S_K202_0125 ME20	3700	3500	5500	≤32	1.30	83	42	12	23	3	18	57.3	6.0	5.4	7.7	5.4	14	11	220	154
12.71	ZV318S_K202_0125 ME30	3500	3500	5000	≤38	1.18	83	42	12	23	3	18	57.3	6.0	5.4	7.7	5.4	14	11	220	154
13.85	ZV318S_K202_0140 ME10	3900	3500	5500	≤19	1.19	83	42	12	23	3	18	57.3	6.1	5.4	7.7	5.4	14	11	220	154
13.85	ZV318S_K202_0140 ME20	3700	3500	5500	≤32	1.19	83	42	12	23	3	18	57.3	6.1	5.4	7.7	5.4	14	11	220	154
13.85	ZV318S_K202_0140 ME30	3500	3500	5000	≤38	1.08	83	42	12	23	3	18	57.3	6.1	5.4	7.7	5.4	14	11	220	154
16.86	ZV318S_K202_0170 ME10	4000	3900	6500	≤19	1.16	83	42	12	23	3	18	57.3	6.2	5.4	7.7	5.4	14	11	220	154
16.86	ZV318S_K202_0170 ME20	3700	3700	6000	≤32	1.07	83	42	12	23	3	18	57.3	6.6	5.4	7.7	5.4	14	11	220	154
16.86	ZV318S_K202_0170 ME30	3500	3500	5000	≤38	0.89	83	42	12	23	3	18	57.3	6.6	5.4	7.7	5.4	14	11	220	154
17.47	ZV318S_K202_0175 ME10	3900	3500	5500	≤19	0.95	83	42	12	23	3	18	57.3	6.6	5.4	7.7	5.4	14	11	220	154
17.47	ZV318S_K202_0175 ME20	3700	3500	5500	≤32	0.95	83	42	12	23	3	18	57.3	6.6	5.4	7.7	5.4	14	11	220	154
17.47	ZV318S_K202_0175 ME30	3500	3500	5000	≤38	0.86	83	42	12	23	3	18	57.3	6.6	5.4	7.7	5.4	14	11	220	154
20.33	ZV318S_K202_0200 ME10	4000	3900	6500	≤19	0.96	83	42	12	23	3	18	57.3	6.4	5.4	7.7	5.4	14	11	220	154
20.33	ZV318S_K202_0200 ME20	3700	3700	6000	≤24	0.89	83	42	12	23	3	18	57.3	7.0	5.4	7.7	5.4	14	11	220	154
23.18	ZV318S_K202_0230 ME10	4000	3900	6500	≤19	0.84	83	42	12	23	3	18	57.3	7.0	5.4	7.7	5.4	14	11	220	154
23.18	ZV318S_K202_0230 ME20	3700	3700	6000	≤32	0.78	83	42	12	23	3	18	57.3	7.0	5.4	7.7	5.4	14	11	220	154
23.18	ZV318S_K202_0230 ME30	3500	3500	5000	≤38	0.65	83	42	12	23	3	18	57.3	7.0	5.4	7.7	5.4	14	11	220	154
25.13	ZV318S_K202_0250 ME10	4000	3900	6500	≤19	0.78	83	42	12	23	3	18	57.3	6.5	5.4	7.7	5.4	14	11	220	154
25.13	ZV318S_K202_0250 ME20	3700	3700	6000	≤24	0.72	83	42	12	23	3	18	57.3	7.0	5.4	7.7	5.4	14	11	220	154
27.95	ZV318S_K202_0280 ME10	4000	3900	6500	≤19	0.70	83	42	12	23	3	18	57.3	7.0	5.4	7.7	5.4	14	11	220	154
27.95	ZV318S_K202_0280 ME20	3700	3700	6000	≤24	0.64	83	42	12	23	3	18	57.3	7.0	5.4	7.7	5.4	14	11	220	154
33.62	ZV318S_K202_0340 ME10	4000	3900	6500	≤19	0.58	83	42	12	23	3	18	57.3	5.4	5.4	6.5	5.4	11	11	185	154
33.62	ZV318S_K202_0340 ME20	3700	3700	6000	≤24	0.54	83	42	12	23	3	18	57.3	5.4	5.4	6.5	5.4	11	11	185	154
34.55	ZV318S_K202_0350 ME10	4000	3900	6500	≤19	0.56	83	42	12	23	3	18	57.3	7.0	5.4	7.7	5.4	14	11	220	154
34.55	ZV318S_K202_0350 ME20	3700	3700	6000	≤24	0.52	83	42	12	23	3	18	57.3	7.0	5.4	7.7	5.4	14	11	220	154
39.45	ZV318S_K203_0390 ME10	4000	3900	6500	≤19	0.49	83	50	21	23	3	18	57.3	7.0	5.4	7.1	5.4	8.8	8.8	202	154
40.39	ZV318S_K202_0400 ME10	4000	3900	6500	≤19	0.48	83	42	12	23	3	18	57.3	4.0	4.0	4.8	4.8	6.9	6.9	139	139
45.22	ZV318S_K203_0450 ME10	4000	3900	6500	≤19	0.43	83	50	21	23	3	18	57.3	7.0	5.4	7.7	5.4	10	10	220	154
46.23	ZV318S_K202_0460 ME10	4000	3900	6500	≤19	0.42	83	42	12	23	3	18	57.3	7.0	5.4	7.7	5.4	14	11	220	154
46.23	ZV318S_K202_0460 ME20	3700	3700	6000	≤24	0.39	83	42	12	23	3	18	57.3	7.0	5.4	7.7	5.4	14	11	220	154
49.76	ZV318S_K203_0500 ME10	4000	3900	6500	≤19	0.39	83	50	21	23	3	18	57.3	7.0	5.4	7.7	5.4	11	11	220	154
50.49	ZV318S_K202_0500 ME10	4000	3900	6500	≤19	0.39	83	42	12	23	3	18	57.3	3.4	3.4	4.0	4.0	6.4	6.4	116	116
54.25	ZV318S_K203_0540 ME10	4000	3900	6500	≤19	0.36	83	50	21	23	3	18	57.3	7.0	5.4	7.7	5.4	12	11	220	154
55.54	ZV318S_K202_0560 ME10	4000	3900	6500	≤19	0.35	83	42	12	23	3	18	57.3	5.5	5.4	6.7	5.4	9.4	9.4	191	154
66.03	ZV318S_K203_0660 ME10	4000	3900	6500	≤19																

12.2 Selection tables 12 ZVK rack and pinion drives

i	Type	n _{1maxDB}		n _{1maxZV}	d _{MW}	v _{zmaxZB}	Δs	Δs _{redII}	Δs _{redI}	C _{lin}	m _n	z	d ₀	F _{zN,S}	F _{zN,E}	F _{zaccS}	F _{zaccE}	F _{zNOT,S}	F _{zNOT,E}	M _{zaccS}	M _{zaccE}
		EL1,2 [rpm]	EL3,4,5,6 [rpm]	[rpm]	[mm]	[m/s]	[μm]	[μm]	[μm]	[N/ μm]	[mm]	[mm]	[kN]	[kN]	[kN]	[kN]	[kN]	[kN]	[kN]	[kN]	[Nm]
ZV3K2 (F_{v2acc,max} = 7,7 kN)																					
79.62	ZV318S_K203_0800 ME10	4000	3900	6500	≤19	0.25	83	50	21	23	3	18	57.3	7.0	5.4	7.7	5.4	14	11	220	154
90.79	ZV318S_K203_0910 ME10	4000	3900	6500	≤19	0.22	83	50	21	23	3	18	57.3	7.0	5.4	7.7	5.4	14	11	220	154
109.5	ZV318S_K203_1090 ME10	4000	3900	6500	≤19	0.18	83	50	21	23	3	18	57.3	7.0	5.4	7.7	5.4	14	11	220	154
135.3	ZV318S_K203_1350 ME10	4000	3900	6500	≤19	0.14	83	50	21	23	3	18	57.3	7.0	5.4	7.7	5.4	14	11	220	154
181.0	ZV318S_K203_1810 ME10	4000	3900	6500	≤19	0.11	83	50	21	23	3	18	57.3	7.0	5.4	7.7	5.4	14	11	220	154
217.5	ZV318S_K203_2180 ME10	4000	3900	6500	≤19	0.09	83	50	21	23	3	18	57.3	5.5	5.4	6.7	5.4	9.4	9.4	191	154
271.9	ZV318S_K203_2720 ME10	4000	3900	6500	≤19	0.07	83	50	21	23	3	18	57.3	4.6	4.6	5.5	5.4	8.8	8.8	159	154
ZV2K3 (F_{v2acc,max} = 10 kN)																					
4.000	ZV225S_K302_0040 ME20	2700	2300	4000	≤32	2.78	77	31	12	30	2	25	53.1	7.7	5.2	8.8	5.2	11	10	233	137
4.000	ZV225S_K302_0040 ME30	2700	2300	4000	≤38	2.78	77	31	12	30	2	25	53.1	7.7	5.2	10	5.2	21	10	274	137
4.364	ZV225S_K302_0044 ME20	2700	2300	4000	≤32	2.55	77	31	12	30	2	25	53.1	7.9	5.2	9.6	5.2	12	10	254	137
4.364	ZV225S_K302_0044 ME30	2700	2300	4000	≤38	2.55	77	31	12	30	2	25	53.1	7.9	5.2	10	5.2	21	10	274	137
5.375	ZV225S_K302_0054 ME20	2700	2300	4000	≤32	2.07	77	31	12	30	2	25	53.1	8.5	5.2	10	5.2	15	10	274	137
5.375	ZV225S_K302_0054 ME30	2700	2300	4000	≤38	2.07	77	31	12	30	2	25	53.1	8.5	5.2	10	5.2	15	10	274	137
6.000	ZV225S_K302_0060 ME20	2700	2300	4000	≤32	1.85	77	31	12	30	2	25	53.1	8.8	5.2	10	5.2	16	10	274	137
6.000	ZV225S_K302_0060 ME30	2700	2300	4000	≤38	1.85	77	31	12	30	2	25	53.1	8.8	5.2	10	5.2	21	10	274	137
6.740	ZV225S_K302_0067 ME20	3200	2800	4500	≤32	1.86	77	31	12	30	2	25	53.1	9.1	5.2	10	5.2	18	10	274	137
6.740	ZV225S_K302_0067 ME30	3200	2800	4500	≤38	1.86	77	31	12	30	2	25	53.1	9.1	5.2	10	5.2	18	10	274	137
7.391	ZV225S_K302_0074 ME20	2700	2300	4000	≤32	1.50	77	31	12	30	2	25	53.1	9.4	5.2	10	5.2	20	10	274	137
7.391	ZV225S_K302_0074 ME30	2700	2300	4000	≤38	1.50	77	31	12	30	2	25	53.1	9.4	5.2	10	5.2	20	10	274	137
8.444	ZV225S_K302_0084 ME10	3200	2800	4500	≤19	1.48	77	31	12	30	2	25	53.1	6.4	5.2	7.4	5.2	9.3	9.3	197	137
8.444	ZV225S_K302_0084 ME20	3200	2800	4500	≤32	1.48	77	31	12	30	2	25	53.1	9.9	5.2	10	5.2	21	10	274	137
8.444	ZV225S_K302_0084 ME30	3200	2800	4500	≤38	1.48	77	31	12	30	2	25	53.1	9.9	5.2	10	5.2	21	10	274	137
9.267	ZV225S_K302_0093 ME20	3200	2800	4500	≤32	1.35	77	31	12	30	2	25	53.1	10	5.2	10	5.2	21	10	274	137
9.267	ZV225S_K302_0093 ME30	3200	2800	4500	≤38	1.35	77	31	12	30	2	25	53.1	10	5.2	10	5.2	21	10	274	137
10.14	ZV225S_K302_0100 ME10	3500	3100	5000	≤19	1.37	77	31	12	30	2	25	53.1	6.6	5.2	8.9	5.2	11	10	236	137
10.14	ZV225S_K302_0100 ME20	3500	3100	5000	≤32	1.37	77	31	12	30	2	25	53.1	10	5.2	10	5.2	21	10	274	137
10.14	ZV225S_K302_0100 ME30	3500	3100	5000	≤38	1.37	77	31	12	30	2	25	53.1	10	5.2	10	5.2	21	10	274	137
11.61	ZV225S_K302_0115 ME10	3200	2800	4500	≤19	1.08	77	31	12	30	2	25	53.1	8.8	5.2	10	5.2	13	10	270	137
11.61	ZV225S_K302_0115 ME20	3200	2800	4500	≤32	1.08	77	31	12	30	2	25	53.1	10	5.2	10	5.2	21	10	274	137
11.61	ZV225S_K302_0115 ME30	3200	2800	4500	≤38	1.08	77	31	12	30	2	25	53.1	10	5.2	10	5.2	21	10	274	137
12.58	ZV225S_K302_0125 ME10	3500	3100	5000	≤19	1.10	77	31	12	30	2	25	53.1	7.0	5.2	10	5.2	14	10	274	137
12.58	ZV225S_K302_0125 ME20	3500	3100	5000	≤32	1.10	77	31	12	30	2	25	53.1	10	5.2	10	5.2	21	10	274	137
12.58	ZV225S_K302_0125 ME30	3500	3100	5000	≤38	1.10	77	31	12	30	2	25	53.1	10	5.2	10	5.2	21	10	274	137
13.94	ZV225S_K302_0140 ME10	3500	3100	5000	≤19	1.00	77	31	12	30	2	25	53.1	9.1	5.2	10	5.2	15	10	274	137
13.94	ZV225S_K302_0140 ME20	3500	3100	5000	≤32	1.00	77	31	12	30	2	25	53.1	10	5.2	10	5.2	21	10	274	137
13.94	ZV225S_K302_0140 ME30	3500	3100	5000	≤38	1.00	77	31	12	30	2	25	53.1	10	5.2	10	5.2	21	10	274	137
16.94	ZV225S_K302_0170 ME10	3800	3500	6000	≤19	0.98	77	31	12	30	2	25	53.1	7.4	5.2	10	5.2	18	10	274	137
16.94	ZV225S_K302_0170 ME20	3700	3500	6000	≤32	0.98	77	31	12	30	2	25	53.1	10	5.2	10	5.2	21	10	274	137
16.94	ZV225S_K302_0170 ME30	3500	3500	5000	≤38	0.82	77	31	12	30	2	25	53.1	10	5.2	10	5.2	21	10	274	137
17.29	ZV225S_K302_0175 ME10	3500	3100	5000	≤19	0.80	77	31	12	30	2	25	53.1	9.7	5.2	10	5.2	19	10	274	137
17.29	ZV225S_K302_0175 ME20	3500	3100	5000	≤32	0.80	77	31	12	30	2	25	53.1	10	5.2	10	5.2	21	10	274	137
17.29	ZV225S_K302_0175 ME30	3500	3100	5000	≤38	0.80	77	31	12	30	2	25	53.1	10	5.2	10	5.2	21	10	274	137
20.28	ZV225S_K302_0200 ME10	3800	3500	6000	≤19	0.82	77	31	12	30	2	25	53.1	7.9	5.2	10	5.2	19	10	274	137
20.28	ZV225S_K302_0200 ME20	3700	3500	6000	≤32	0.82	77	31	12	30	2	25	53.1	10	5.2	10	5.2	21	10	274	137
20.28	ZV225S_K302_0200 ME30	3500	3500	5000	≤38	0.69	77	31	12	30	2	25	53.1	10	5.2	10	5.2	21	10	274	137
23.29	ZV225S_K302_0230 ME10	3800	3500	6000	≤19	0.72	77	31	12	30	2	25	53.1	10	5.2	10	5.2	21	10	274	137
23.29	ZV225S_K302_0230 ME20	3700	3500	6000	≤32	0.72	77	31	12	30	2	25	53.1	10	5.2	10	5.2	21	10	274	137
23.29	ZV225S_K302_0230 ME30	3500	3500	5000	≤38	0.60	77	31	12	30	2	25	53.1	10	5.2	10	5.2	21	10	274	137
25.26	ZV225S_K302_0250 ME10	3800	3500	6000	≤19	0.66	77	31	12	30	2	25	53.1	8.0	5.2	10	5.2	21	10	274	137
25.26	ZV225S_K302_0250 ME20	3700	3500	6000	≤24	0.66	77	31	12	30	2	25	53.1	10	5.2	10	5.2	21	10	274	137
27.88	ZV225S_K302_0280 ME10	3800	3500	6000	≤19	0.60	77	31	12	30	2	25	53.1	10	5.2	10	5.2	21	10	274	137
27.88	ZV225S_K302_0280 ME20	3700	3500	6000	≤32	0.60	77	31	12	30	2	25	53.1	10	5.2	10	5.2	21	10	274	137
27.88	ZV225S_K302_0280 ME30	3500	3500	5000	≤38	0.50	77	31	12	30	2	25	53.1	10	5.2	10	5.2	21	10	274	137
32.65	ZV225S_K303_0330 ME20	3700	3500	6000	≤24	0.51	77	39	19	30	2	25	53.1	10	5.2	10	5.2	21	10	274	137
33.62	ZV225S_K302_0340 ME10	3800	3500	6000	≤19	0.50	77	31	12	30	2	25	53.1	8.3	5.2	10	5.2	19	10	274	137
33.62	ZV225S_K302_0340 ME20	3700	3500	6000	≤24	0.50	77	31	12	30	2	25	53.1	9.4	5.2	10	5.2	19	10	274	137
34.73	ZV225S_K302_0350 ME10	3800	3500	6000	≤19	0.48	77	31	12	30	2	25	53.1	10	5.2	10	5.2	21	10	274	137
34.73	ZV225S_K302_0350 ME20	3700	3500	6000	≤24	0.48	77	31	12	30	2	25	53.1	10	5.2	10	5.2	21	10	274	137
35.83	ZV225S_K303_0360 ME20	3700	3500	6000	≤24	0.47	77	39	19	30	2	25	53.1	10	5.2	10	5.2	21	10	274	137
39.19	ZV225S_K303_0390 ME20	3700	3500	6000	≤24	0.43	77	39	19	30	2	25	53.1	10	5.2	10	5.2	21	10	274	137
40.51	ZV225S_K302_0410 ME10	3800	3500	6000	≤19	0.41	77	31	12	30	2	25	53.1	7.3	5.2	8.7	5.2	15	10	231	137
40.51	ZV225S_K302_0410 ME20</																				

i	Type	n _{1maxDB}		n _{1maxZV}	d _{MW}	v _{f2maxZB}	Δs	Δs _{redII}	Δs _{redI}	C _{lin}	m _n	z	d ₀	F _{f2N,S}	F _{f2N,E}	F _{f2accS}	F _{f2accE}	F _{f2NOT,S}	F _{f2NOT,E}	M _{2accS}	M _{2accE}		
		EL1,2	EL3,4,5,6																				
		[rpm]	[rpm]	[rpm]	[mm]	[m/s]	[μm]	[μm]	[μm]	[N/μm]	[mm]			[mm]	[kN]	[kN]	[kN]	[kN]	[kN]	[kN]	[Nm]	[Nm]	
ZV2K3 (F_{v2acc,max} = 10 kN)																							
46.23	ZV225S_K302_0460 ME10	3800	3500	6000	≤19	0.36	77	31	12	30	2	25	53.1	10	5.2	10	5.2	21	10	274	137		
46.23	ZV225S_K302_0460 ME20	3700	3500	6000	≤24	0.36	77	31	12	30	2	25	53.1	10	5.2	10	5.2	21	10	274	137		
48.63	ZV225S_K303_0490 ME20	3700	3500	6000	≤24	0.34	77	39	19	30	2	25	53.1	10	5.2	10	5.2	21	10	274	137		
49.26	ZV225S_K303_0490 ME10	3800	3500	6000	≤19	0.34	77	39	19	30	2	25	53.1	9.5	5.2	9.5	5.2	12	10	253	137		
50.49	ZV225S_K302_0500 ME10	3800	3500	6000	≤19	0.33	77	31	12	30	2	25	53.1	5.8	5.2	6.5	5.2	8.2	8.2	173	137		
53.88	ZV225S_K303_0540 ME20	3700	3500	6000	≤24	0.31	77	39	19	30	2	25	53.1	10	5.2	10	5.2	21	10	274	137		
54.58	ZV225S_K303_0550 ME10	3800	3500	6000	≤19	0.31	77	39	19	30	2	25	53.1	10	5.2	10	5.2	13	10	274	137		
55.71	ZV225S_K302_0560 ME10	3800	3500	6000	≤19	0.30	77	31	12	30	2	25	53.1	10	5.2	10	5.2	20	10	274	137		
55.71	ZV225S_K302_0560 ME20	3700	3500	6000	≤24	0.30	77	31	12	30	2	25	53.1	10	5.2	10	5.2	20	10	274	137		
65.50	ZV225S_K303_0650 ME20	3700	3500	6000	≤24	0.25	77	39	19	30	2	25	53.1	10	5.2	10	5.2	21	10	274	137		
66.35	ZV225S_K303_0660 ME10	3800	3500	6000	≤19	0.25	77	39	19	30	2	25	53.1	10	5.2	10	5.2	16	10	274	137		
66.87	ZV225S_K303_0670 ME20	3700	3500	6000	≤24	0.25	77	39	19	30	2	25	53.1	10	5.2	10	5.2	21	10	274	137		
67.73	ZV225S_K303_0680 ME10	3800	3500	6000	≤19	0.25	77	39	19	30	2	25	53.1	10	5.2	10	5.2	16	10	274	137		
69.43	ZV225S_K302_0690 ME10	3800	3500	6000	≤19	0.24	77	31	12	30	2	25	53.1	8.0	5.2	9.0	5.2	11	10	238	137		
78.41	ZV225S_K303_0780 ME20	3700	3500	6000	≤24	0.21	77	39	19	30	2	25	53.1	10	5.2	10	5.2	21	10	274	137		
79.42	ZV225S_K303_0790 ME10	3800	3500	6000	≤19	0.21	77	39	19	30	2	25	53.1	10	5.2	10	5.2	19	10	274	137		
90.06	ZV225S_K303_0900 ME20	3700	3500	6000	≤24	0.19	77	39	19	30	2	25	53.1	10	5.2	10	5.2	21	10	274	137		
91.23	ZV225S_K303_0910 ME10	3800	3500	6000	≤19	0.18	77	39	19	30	2	25	53.1	10	5.2	10	5.2	21	10	274	137		
107.8	ZV225S_K303_1080 ME20	3700	3500	6000	≤24	0.16	77	39	19	30	2	25	53.1	10	5.2	10	5.2	21	10	274	137		
109.2	ZV225S_K303_1090 ME10	3800	3500	6000	≤19	0.15	77	39	19	30	2	25	53.1	10	5.2	10	5.2	21	10	274	137		
134.3	ZV225S_K303_1340 ME20	3700	3500	6000	≤24	0.12	77	39	19	30	2	25	53.1	10	5.2	10	5.2	21	10	274	137		
136.0	ZV225S_K303_1360 ME10	3800	3500	6000	≤19	0.12	77	39	19	30	2	25	53.1	10	5.2	10	5.2	21	10	274	137		
178.7	ZV225S_K303_1790 ME20	3700	3500	6000	≤24	0.09	77	39	19	30	2	25	53.1	10	5.2	10	5.2	21	10	274	137		
181.0	ZV225S_K303_1810 ME10	3800	3500	6000	≤19	0.09	77	39	19	30	2	25	53.1	10	5.2	10	5.2	21	10	274	137		
218.2	ZV225S_K303_2180 ME10	3800	3500	6000	≤19	0.08	77	39	19	30	2	25	53.1	10	5.2	10	5.2	20	10	274	137		
271.9	ZV225S_K303_2720 ME10	3800	3500	6000	≤19	0.06	77	39	19	30	2	25	53.1	8.0	5.2	9.0	5.2	11	10	238	137		
ZV3K3 (F_{v2acc,max} = 11 kN)																							
4.000	ZV318S_K302_0040 ME20	2700	2300	4000	≤32	3.00	83	33	12	29	3	18	57.3	7.1	5.3	8.1	5.3	10	10	233	153		
4.000	ZV318S_K302_0040 ME30	2700	2300	4000	≤38	3.00	83	33	12	30	3	18	57.3	7.1	5.3	11	5.3	22	11	306	153		
4.364	ZV318S_K302_0044 ME20	2700	2300	4000	≤32	2.75	83	33	12	29	3	18	57.3	7.3	5.3	8.9	5.3	11	11	254	153		
4.364	ZV318S_K302_0044 ME30	2700	2300	4000	≤38	2.75	83	33	12	30	3	18	57.3	7.3	5.3	11	5.3	22	11	308	153		
5.375	ZV318S_K302_0054 ME20	2700	2300	4000	≤32	2.23	83	33	12	30	3	18	57.3	7.8	5.3	11	5.3	14	11	308	153		
5.375	ZV318S_K302_0054 ME30	2700	2300	4000	≤38	2.23	83	33	12	30	3	18	57.3	7.8	5.3	11	5.3	14	11	308	153		
6.000	ZV318S_K302_0060 ME20	2700	2300	4000	≤32	2.00	83	33	12	30	3	18	57.3	8.1	5.3	11	5.3	15	11	308	153		
6.000	ZV318S_K302_0060 ME30	2700	2300	4000	≤38	2.00	83	33	12	30	3	18	57.3	8.1	5.3	11	5.3	22	11	308	153		
6.740	ZV318S_K302_0067 ME20	3200	2800	4500	≤32	2.00	83	33	12	30	3	18	57.3	8.5	5.3	11	5.3	17	11	308	153		
6.740	ZV318S_K302_0067 ME30	3200	2800	4500	≤38	2.00	83	33	12	30	3	18	57.3	8.5	5.3	11	5.3	17	11	308	153		
7.391	ZV318S_K302_0074 ME20	2700	2300	4000	≤32	1.62	83	33	12	30	3	18	57.3	8.7	5.3	11	5.3	19	11	308	153		
7.391	ZV318S_K302_0074 ME30	2700	2300	4000	≤38	1.62	83	33	12	30	3	18	57.3	8.7	5.3	11	5.3	19	11	308	153		
8.444	ZV318S_K302_0084 ME10	3200	2800	4500	≤19	1.60	83	33	12	29	3	18	57.3	5.9	5.3	6.9	5.3	8.6	8.6	197	153		
8.444	ZV318S_K302_0084 ME20	3200	2800	4500	≤32	1.60	83	33	12	30	3	18	57.3	9.1	5.3	11	5.3	21	11	308	153		
8.444	ZV318S_K302_0084 ME30	3200	2800	4500	≤38	1.60	83	33	12	30	3	18	57.3	9.1	5.3	11	5.3	21	11	308	153		
9.267	ZV318S_K302_0093 ME20	3200	2800	4500	≤32	1.46	83	33	12	30	3	18	57.3	9.4	5.3	11	5.3	22	11	308	153		
9.267	ZV318S_K302_0093 ME30	3200	2800	4500	≤38	1.46	83	33	12	30	3	18	57.3	9.4	5.3	11	5.3	22	11	308	153		
10.14	ZV318S_K302_0100 ME10	3500	3100	5000	≤19	1.48	83	33	12	30	3	18	57.3	6.1	5.3	8.2	5.3	10	10	236	153		
10.14	ZV318S_K302_0100 ME20	3500	3100	5000	≤32	1.48	83	33	12	30	3	18	57.3	9.7	5.3	11	5.3	22	11	308	153		
10.14	ZV318S_K302_0100 ME30	3500	3100	5000	≤38	1.48	83	33	12	30	3	18	57.3	9.7	5.3	11	5.3	22	11	308	153		
11.61	ZV318S_K302_0115 ME10	3200	2800	4500	≤19	1.16	83	33	12	30	3	18	57.3	8.1	5.3	9.4	5.3	12	11	270	153		
11.61	ZV318S_K302_0115 ME20	3200	2800	4500	≤32	1.16	83	33	12	30	3	18	57.3	10	5.3	11	5.3	22	11	308	153		
11.61	ZV318S_K302_0115 ME30	3200	2800	4500	≤38	1.16	83	33	12	30	3	18	57.3	10	5.3	11	5.3	22	11	308	153		
12.58	ZV318S_K302_0125 ME10	3500	3100	5000	≤19	1.19	83	33	12	30	3	18	57.3	6.5	5.3	10	5.3	13	11	293	153		
12.58	ZV318S_K302_0125 ME20	3500	3100	5000	≤32	1.19	83	33	12	30	3	18	57.3	10	5.3	11	5.3	22	11	308	153		
12.58	ZV318S_K302_0125 ME30	3500	3100	5000	≤38	1.19	83	33	12	30	3	18	57.3	10	5.3	11	5.3	22	11	308	153		
13.94	ZV318S_K302_0140 ME10	3500	3100	5000	≤19	1.08	83	33	12	30	3	18	57.3	8.4	5.3	11	5.3	14	11	308	153		
13.94	ZV318S_K302_0140 ME20	3500	3100	5000	≤32	1.08	83	33	12	30	3	18	57.3	11	5.3	11	5.3	22	11	308	153		
13.94	ZV318S_K302_0140 ME30	3500	3100	5000	≤38	1.08	83	33	12	30	3	18	57.3	11	5.3	11	5.3	22	11	308	153		
16.94	ZV318S_K302_0170 ME10	3800	3500	6000	≤19	1.06	83	33	12	30	3	18	57.3	6.9	5.3	11	5.3	16	11	308	153		
16.94	ZV318S_K302_0170 ME20	3700	3500	6000	≤32	1.06	83	33	12	30	3	18	57.3	11	5.3	11	5.3	22	11	308	153		
16.94	ZV318S_K302_0170 ME30	3500	3500	5000	≤38	0.89	83	33	12	30	3	18	57.3	11	5.3	11	5.3	22	11	308	153		
17.29	ZV318S_K302_0175 ME10	3500	3100	5000	≤19	0.87	83	33	12	30	3	18	57.3	9.0	5.3	11	5.3	18	11	308	153		
17.29	ZV318S_K302_0175 ME20	3500	3100	5000	≤32	0.87	83	33	12	30	3	18	57.3	11	5.3	11	5.3	22	11	308	153		
17.29	ZV318S_K302_0175 ME30	3500	3100	5000	≤38	0.87	83	33	12	30	3	18	57.3										

12.2 Selection tables 12 ZVK rack and pinion drives

i	Type	n _{1maxDB}		n _{1maxZV}	d _{MW}	v _{2maxZB}	Δs	Δs _{redII}	Δs _{redI}	C _{in}	m _n	z	d ₀	F _{2N,S}	F _{2N,E}	F _{2accS}	F _{2accE}	F _{2NOT,S}	F _{2NOT,E}	M _{2accS}	M _{2accE}
		EL1,2 [rpm]	EL3,4,5,6 [rpm]																		
ZV3K3 (F_{v2acc,max} = 11 kN)																					
20.28	ZV318S_K302_0200 ME30	3500	3500	5000	≤38	0.74	83	33	12	30	3	18	57.3	11	5.3	11	5.3	22	11	308	153
23.29	ZV318S_K302_0230 ME10	3800	3500	6000	≤19	0.77	83	33	12	30	3	18	57.3	9.5	5.3	11	5.3	22	11	308	153
23.29	ZV318S_K302_0230 ME20	3700	3500	6000	≤32	0.77	83	33	12	30	3	18	57.3	11	5.3	11	5.3	22	11	308	153
23.29	ZV318S_K302_0230 ME30	3500	3500	5000	≤38	0.64	83	33	12	30	3	18	57.3	11	5.3	11	5.3	22	11	308	153
25.26	ZV318S_K302_0250 ME10	3800	3500	6000	≤19	0.71	83	33	12	30	3	18	57.3	7.4	5.3	11	5.3	21	11	308	153
25.26	ZV318S_K302_0250 ME20	3700	3500	6000	≤24	0.71	83	33	12	30	3	18	57.3	11	5.3	11	5.3	21	11	308	153
27.88	ZV318S_K302_0280 ME10	3800	3500	6000	≤19	0.65	83	33	12	30	3	18	57.3	10	5.3	11	5.3	22	11	308	153
27.88	ZV318S_K302_0280 ME20	3700	3500	6000	≤32	0.65	83	33	12	30	3	18	57.3	11	5.3	11	5.3	22	11	308	153
27.88	ZV318S_K302_0280 ME30	3500	3500	5000	≤38	0.54	83	33	12	30	3	18	57.3	11	5.3	11	5.3	22	11	308	153
32.65	ZV318S_K303_0330 ME20	3700	3500	6000	≤24	0.55	83	42	21	30	3	18	57.3	11	5.3	11	5.3	20	11	308	153
33.62	ZV318S_K302_0340 ME10	3800	3500	6000	≤19	0.54	83	33	12	30	3	18	57.3	7.7	5.3	10	5.3	17	11	300	153
33.62	ZV318S_K302_0340 ME20	3700	3500	6000	≤24	0.54	83	33	12	30	3	18	57.3	8.7	5.3	10	5.3	17	11	300	153
34.73	ZV318S_K302_0350 ME10	3800	3500	6000	≤19	0.52	83	33	12	30	3	18	57.3	10	5.3	11	5.3	22	11	308	153
34.73	ZV318S_K302_0350 ME20	3700	3500	6000	≤24	0.52	83	33	12	30	3	18	57.3	11	5.3	11	5.3	22	11	308	153
35.83	ZV318S_K303_0360 ME20	3700	3500	6000	≤24	0.50	83	42	21	30	3	18	57.3	11	5.3	11	5.3	22	11	308	153
39.19	ZV318S_K303_0390 ME20	3700	3500	6000	≤24	0.46	83	42	21	30	3	18	57.3	11	5.3	11	5.3	22	11	308	153
40.51	ZV318S_K302_0410 ME10	3800	3500	6000	≤19	0.44	83	33	12	30	3	18	57.3	6.7	5.3	8.1	5.3	13	11	231	153
40.51	ZV318S_K302_0410 ME20	3700	3500	6000	≤24	0.44	83	33	12	30	3	18	57.3	6.7	5.3	8.1	5.3	13	11	231	153
44.89	ZV318S_K303_0450 ME20	3700	3500	6000	≤24	0.40	83	42	21	30	3	18	57.3	11	5.3	11	5.3	22	11	308	153
46.23	ZV318S_K302_0460 ME10	3800	3500	6000	≤19	0.39	83	33	12	30	3	18	57.3	11	5.3	11	5.3	22	11	308	153
46.23	ZV318S_K302_0460 ME20	3700	3500	6000	≤24	0.39	83	33	12	30	3	18	57.3	11	5.3	11	5.3	22	11	308	153
48.63	ZV318S_K303_0490 ME20	3700	3500	6000	≤24	0.37	83	42	21	30	3	18	57.3	11	5.3	11	5.3	22	11	308	153
49.26	ZV318S_K303_0490 ME10	3800	3500	6000	≤19	0.37	83	42	21	30	3	18	57.3	8.8	5.3	8.8	5.3	11	11	253	153
50.49	ZV318S_K302_0500 ME10	3800	3500	6000	≤19	0.36	83	33	12	30	3	18	57.3	5.4	5.3	6.0	5.3	7.6	7.6	173	153
53.88	ZV318S_K303_0540 ME20	3700	3500	6000	≤24	0.33	83	42	21	30	3	18	57.3	11	5.3	11	5.3	22	11	308	153
54.58	ZV318S_K303_0550 ME10	3800	3500	6000	≤19	0.33	83	42	21	30	3	18	57.3	9.8	5.3	9.8	5.3	12	11	280	153
55.71	ZV318S_K302_0560 ME10	3800	3500	6000	≤19	0.32	83	33	12	30	3	18	57.3	9.2	5.3	11	5.3	18	11	308	153
55.71	ZV318S_K302_0560 ME20	3700	3500	6000	≤24	0.32	83	33	12	30	3	18	57.3	9.2	5.3	11	5.3	18	11	308	153
65.50	ZV318S_K303_0650 ME20	3700	3500	6000	≤24	0.28	83	42	21	30	3	18	57.3	11	5.3	11	5.3	22	11	308	153
66.35	ZV318S_K303_0660 ME10	3800	3500	6000	≤19	0.27	83	42	21	30	3	18	57.3	11	5.3	11	5.3	15	11	308	153
66.87	ZV318S_K303_0670 ME20	3700	3500	6000	≤24	0.27	83	42	21	30	3	18	57.3	11	5.3	11	5.3	22	11	308	153
67.73	ZV318S_K303_0680 ME10	3800	3500	6000	≤19	0.27	83	42	21	30	3	18	57.3	11	5.3	11	5.3	15	11	308	153
69.43	ZV318S_K302_0690 ME10	3800	3500	6000	≤19	0.26	83	33	12	30	3	18	57.3	7.4	5.3	8.3	5.3	10	10	238	153
78.41	ZV318S_K303_0780 ME20	3700	3500	6000	≤24	0.23	83	42	21	30	3	18	57.3	11	5.3	11	5.3	22	11	308	153
79.42	ZV318S_K303_0790 ME10	3800	3500	6000	≤19	0.23	83	42	21	30	3	18	57.3	11	5.3	11	5.3	18	11	308	153
90.06	ZV318S_K303_0900 ME20	3700	3500	6000	≤24	0.20	83	42	21	30	3	18	57.3	11	5.3	11	5.3	22	11	308	153
91.23	ZV318S_K303_0910 ME10	3800	3500	6000	≤19	0.20	83	42	21	30	3	18	57.3	11	5.3	11	5.3	20	11	308	153
107.8	ZV318S_K303_1080 ME20	3700	3500	6000	≤24	0.17	83	42	21	30	3	18	57.3	11	5.3	11	5.3	22	11	308	153
109.2	ZV318S_K303_1090 ME10	3800	3500	6000	≤19	0.17	83	42	21	30	3	18	57.3	11	5.3	11	5.3	22	11	308	153
134.3	ZV318S_K303_1340 ME20	3700	3500	6000	≤24	0.13	83	42	21	30	3	18	57.3	11	5.3	11	5.3	22	11	308	153
136.0	ZV318S_K303_1360 ME10	3800	3500	6000	≤19	0.13	83	42	21	30	3	18	57.3	11	5.3	11	5.3	22	11	308	153
178.7	ZV318S_K303_1790 ME20	3700	3500	6000	≤24	0.10	83	42	21	30	3	18	57.3	11	5.3	11	5.3	22	11	308	153
181.0	ZV318S_K303_1810 ME10	3800	3500	6000	≤19	0.10	83	42	21	30	3	18	57.3	11	5.3	11	5.3	22	11	308	153
218.2	ZV318S_K303_2180 ME10	3800	3500	6000	≤19	0.08	83	42	21	30	3	18	57.3	9.2	5.3	11	5.3	18	11	308	153
271.9	ZV318S_K303_2720 ME10	3800	3500	6000	≤19	0.07	83	42	21	30	3	18	57.3	7.4	5.3	8.3	5.3	10	10	238	153
ZV3K4 (F_{v2acc,max} = 16 kN)																					
4.000	ZV322S_K402_0040 ME30	2600	2200	3800	≤38	3.48	102	41	15	34	3	22	70.0	8.7	6.6	13	6.6	22	13	459	232
4.000	ZV322S_K402_0040 ME40	2600	2200	3800	≤48	3.48	102	41	15	34	3	22	70.0	8.7	6.6	13	6.6	22	13	459	232
4.364	ZV322S_K402_0044 ME30	2600	2200	3800	≤38	3.19	102	41	15	34	3	22	70.0	9.0	6.6	13	6.6	24	13	472	232
4.364	ZV322S_K402_0044 ME40	2600	2200	3800	≤48	3.19	102	41	15	34	3	22	70.0	9.0	6.6	13	6.6	24	13	472	232
5.422	ZV322S_K402_0054 ME30	2600	2200	3800	≤38	2.57	102	41	15	34	3	22	70.0	9.7	6.6	14	6.6	30	13	508	232
5.422	ZV322S_K402_0054 ME40	2600	2200	3800	≤48	2.57	102	41	15	34	3	22	70.0	9.7	6.6	14	6.6	30	13	508	232
6.000	ZV322S_K402_0060 ME30	2600	2200	3800	≤38	2.32	102	41	15	34	3	22	70.0	10	6.6	15	6.6	31	13	525	232
6.000	ZV322S_K402_0060 ME40	2600	2200	3800	≤48	2.32	102	41	15	34	3	22	70.0	10	6.6	15	6.6	31	13	525	232
6.719	ZV322S_K402_0067 ME20	3000	2600	4500	≤32	2.46	102	41	15	34	3	22	70.0	10	6.6	11	6.6	14	13	391	232
6.719	ZV322S_K402_0067 ME30	3000	2600	4500	≤38	2.46	102	41	15	34	3	22	70.0	10	6.6	16	6.6	31	13	545	232
6.719	ZV322S_K402_0067 ME40	3000	2600	4500	≤48	2.46	102	41	15	34	3	22	70.0	10	6.6	16	6.6	31	13	545	232
7.456	ZV322S_K402_0075 ME30	2600	2200	3800	≤38	1.87	102	41	15	34	3	22	70.0	11	6.6	16	6.6	31	13	564	232
7.456	ZV322S_K402_0075 ME40	2600	2200	3800	≤48	1.87	102	41	15	34	3	22	70.0	11	6.6	16	6.6	31	13	564	232
8.377	ZV322S_K402_0084 ME20	3000	2600	4500	≤32	1.97	102	41	15	34	3	22	70.0	11	6.6	14	6.6	17	13	488	232
8.377	ZV322S_K402_0084 ME30	3000	2600	4500	≤38	1.97	102	41	15	34	3	22	70.0	11	6.6	16	6.6	31	13	577	232
8.377	ZV322S_K402_0084 ME40	3000	2600	4500	≤48	1.97	102	41	15	34	3	22	70.0	11	6.6	16	6.6	31	13	577	232
9.238	ZV322S_K402_0092 ME20	3000	2600	4500	≤32	1.79	102	41	15	34	3	22									

i	Type	n _{1maxDB}		n _{1maxZV}	d _{MW}	v _{ZmaxZB}	Δs	Δs _{redII}	Δs _{redI}	C _{lin}	m _n	z	d ₀	F _{ZN,S}	F _{ZN,E}	F _{ZaccS}	F _{ZaccE}	F _{ZNOT,S}	F _{ZNOT,E}	M _{2accS}	M _{2accE}
		EL1,2	EL3,4,5,6																		
		[rpm]	[rpm]	[rpm]	[mm]	[m/s]	[μm]	[μm]	[μm]	[N/μm]	[mm]	[mm]	[kN]	[kN]	[kN]	[kN]	[kN]	[kN]	[kN]	[kN]	[Nm]
ZV3K4 (F_{v2acc,max} = 16 kN)																					
9.238	ZV322S_K402_0092 ME40	3000	2600	4500	≤48	1.79	102	41	15	34	3	22	70.0	12	6.6	16	6.6	31	13	577	232
10.10	ZV322S_K402_0100 ME20	3400	3000	5000	≤32	1.82	102	41	15	34	3	22	70.0	12	6.6	16	6.6	21	13	577	232
10.10	ZV322S_K402_0100 ME30	3400	3000	5000	≤38	1.82	102	41	15	34	3	22	70.0	12	6.6	16	6.6	31	13	577	232
10.10	ZV322S_K402_0100 ME40	3000	3000	4500	≤48	1.63	102	41	15	34	3	22	70.0	12	6.6	16	6.6	31	13	577	232
11.52	ZV322S_K402_0115 ME20	3000	2600	4500	≤32	1.43	102	41	15	34	3	22	70.0	12	6.6	16	6.6	24	13	577	232
11.52	ZV322S_K402_0115 ME30	3000	2600	4500	≤38	1.43	102	41	15	34	3	22	70.0	12	6.6	16	6.6	31	13	577	232
11.52	ZV322S_K402_0115 ME40	3000	2600	4500	≤48	1.43	102	41	15	34	3	22	70.0	12	6.6	16	6.6	31	13	577	232
12.66	ZV322S_K402_0125 ME20	3400	3000	5000	≤32	1.45	102	41	15	34	3	22	70.0	13	6.6	16	6.6	25	13	577	232
12.66	ZV322S_K402_0125 ME30	3400	3000	5000	≤38	1.45	102	41	15	34	3	22	70.0	13	6.6	16	6.6	31	13	577	232
12.66	ZV322S_K402_0125 ME40	3000	3000	4500	≤48	1.30	102	41	15	34	3	22	70.0	13	6.6	16	6.6	31	13	577	232
13.89	ZV322S_K402_0140 ME20	3400	3000	5000	≤32	1.32	102	41	15	34	3	22	70.0	13	6.6	16	6.6	29	13	577	232
13.89	ZV322S_K402_0140 ME30	3400	3000	5000	≤38	1.32	102	41	15	34	3	22	70.0	13	6.6	16	6.6	31	13	577	232
13.89	ZV322S_K402_0140 ME40	3000	3000	4500	≤48	1.19	102	41	15	34	3	22	70.0	13	6.6	16	6.6	31	13	577	232
16.94	ZV322S_K402_0170 ME20	3600	3300	5500	≤32	1.19	102	41	15	34	3	22	70.0	14	6.6	16	6.6	29	13	577	232
16.94	ZV322S_K402_0170 ME30	3500	3300	5000	≤38	1.08	102	41	15	34	3	22	70.0	14	6.6	16	6.6	31	13	577	232
16.94	ZV322S_K402_0170 ME40	3000	3000	4500	≤48	0.97	102	41	15	34	3	22	70.0	14	6.6	16	6.6	31	13	577	232
17.41	ZV322S_K402_0175 ME20	3400	3000	5000	≤32	1.05	102	41	15	34	3	22	70.0	14	6.6	16	6.6	31	13	577	232
17.41	ZV322S_K402_0175 ME30	3400	3000	5000	≤38	1.05	102	41	15	34	3	22	70.0	14	6.6	16	6.6	31	13	577	232
17.41	ZV322S_K402_0175 ME40	3000	3000	4500	≤48	0.95	102	41	15	34	3	22	70.0	14	6.6	16	6.6	31	13	577	232
20.20	ZV322S_K402_0200 ME20	3600	3300	5500	≤32	1.00	102	41	15	34	3	22	70.0	15	6.6	16	6.6	31	13	577	232
20.20	ZV322S_K402_0200 ME30	3500	3300	5000	≤38	0.91	102	41	15	34	3	22	70.0	15	6.6	16	6.6	31	13	577	232
23.29	ZV322S_K402_0230 ME20	3600	3300	5500	≤32	0.87	102	41	15	34	3	22	70.0	16	6.6	16	6.6	31	13	577	232
23.29	ZV322S_K402_0230 ME30	3500	3300	5000	≤38	0.79	102	41	15	34	3	22	70.0	16	6.6	16	6.6	31	13	577	232
23.29	ZV322S_K402_0230 ME40	3000	3000	4500	≤48	0.71	102	41	15	34	3	22	70.0	16	6.6	16	6.6	31	13	577	232
25.28	ZV322S_K402_0250 ME20	3600	3300	5500	≤32	0.80	102	41	15	34	3	22	70.0	14	6.6	16	6.6	29	13	577	232
25.28	ZV322S_K402_0250 ME30	3500	3300	5000	≤38	0.73	102	41	15	34	3	22	70.0	14	6.6	16	6.6	29	13	577	232
27.77	ZV322S_K402_0280 ME20	3600	3300	5500	≤32	0.73	102	41	15	34	3	22	70.0	16	6.6	16	6.6	31	13	577	232
27.77	ZV322S_K402_0280 ME30	3500	3300	5000	≤38	0.66	102	41	15	34	3	22	70.0	16	6.6	16	6.6	31	13	577	232
32.39	ZV322S_K403_0320 ME20	3600	3300	5500	≤24	0.62	102	51	25	34	3	22	70.0	13	6.6	13	6.6	16	13	462	232
33.68	ZV322S_K402_0340 ME20	3600	3300	5500	≤24	0.60	102	41	15	34	3	22	70.0	11	6.6	13	6.6	20	13	467	232
34.76	ZV322S_K402_0350 ME20	3600	3300	5500	≤32	0.58	102	41	15	34	3	22	70.0	16	6.6	16	6.6	31	13	577	232
34.76	ZV322S_K402_0350 ME30	3500	3300	5000	≤38	0.53	102	41	15	34	3	22	70.0	16	6.6	16	6.6	31	13	577	232
35.72	ZV322S_K403_0360 ME20	3600	3300	5500	≤24	0.57	102	51	25	34	3	22	70.0	15	6.6	15	6.6	18	13	509	232
39.05	ZV322S_K403_0390 ME20	3600	3300	5500	≤24	0.52	102	51	25	34	3	22	70.0	16	6.6	16	6.6	20	13	557	232
40.51	ZV322S_K402_0410 ME20	3600	3300	5500	≤24	0.50	102	41	15	34	3	22	70.0	8.8	6.6	11	6.6	18	13	370	232
44.54	ZV322S_K403_0450 ME20	3600	3300	5500	≤24	0.45	102	51	25	34	3	22	70.0	16	6.6	16	6.6	23	13	577	232
46.31	ZV322S_K402_0460 ME20	3600	3300	5500	≤24	0.44	102	41	15	34	3	22	70.0	15	6.6	16	6.6	28	13	577	232
48.94	ZV322S_K403_0490 ME20	3600	3300	5500	≤24	0.41	102	51	25	34	3	22	70.0	16	6.6	16	6.6	25	13	577	232
50.43	ZV322S_K402_0500 ME20	3600	3300	5500	≤24	0.40	102	41	15	34	3	22	70.0	7.7	6.6	9.2	6.6	15	13	323	232
53.69	ZV322S_K403_0540 ME20	3600	3300	5500	≤24	0.38	102	51	25	34	3	22	70.0	16	6.6	16	6.6	27	13	577	232
55.71	ZV322S_K402_0560 ME20	3600	3300	5500	≤24	0.36	102	41	15	34	3	22	70.0	12	6.6	15	6.6	24	13	508	232
65.50	ZV322S_K403_0650 ME20	3600	3300	5500	≤24	0.31	102	51	25	34	3	22	70.0	16	6.6	16	6.6	29	13	577	232
66.35	ZV322S_K403_0660 ME10	3600	3300	5500	≤19	0.30	102	51	25	34	3	22	70.0	9.7	6.6	9.7	6.6	12	12	340	232
67.30	ZV322S_K403_0670 ME20	3600	3300	5500	≤24	0.30	102	51	25	34	3	22	70.0	16	6.6	16	6.6	31	13	577	232
69.34	ZV322S_K402_0690 ME20	3600	3300	5500	≤24	0.29	102	41	15	34	3	22	70.0	11	6.6	13	6.6	21	13	445	232
78.10	ZV322S_K403_0780 ME20	3600	3300	5500	≤24	0.26	102	51	25	34	3	22	70.0	16	6.6	16	6.6	31	13	577	232
79.11	ZV322S_K403_0790 ME10	3600	3300	5500	≤19	0.26	102	51	25	34	3	22	70.0	12	6.6	12	6.6	14	13	406	232
90.06	ZV322S_K403_0900 ME20	3600	3300	5500	≤24	0.22	102	51	25	34	3	22	70.0	16	6.6	16	6.6	31	13	577	232
91.23	ZV322S_K403_0910 ME10	3600	3300	5500	≤19	0.22	102	51	25	34	3	22	70.0	13	6.6	13	6.6	17	13	468	232
107.4	ZV322S_K403_1070 ME20	3600	3300	5500	≤24	0.19	102	51	25	34	3	22	70.0	16	6.6	16	6.6	31	13	577	232
108.8	ZV322S_K403_1090 ME10	3600	3300	5500	≤19	0.19	102	51	25	34	3	22	70.0	16	6.6	16	6.6	20	13	558	232
134.4	ZV322S_K403_1340 ME20	3600	3300	5500	≤24	0.15	102	51	25	34	3	22	70.0	16	6.6	16	6.6	31	13	577	232
136.1	ZV322S_K403_1360 ME10	3600	3300	5500	≤19	0.15	102	51	25	34	3	22	70.0	16	6.6	16	6.6	23	13	577	232
179.1	ZV322S_K403_1790 ME20	3600	3300	5500	≤24	0.11	102	51	25	34	3	22	70.0	15	6.6	16	6.6	28	13	577	232
181.4	ZV322S_K403_1810 ME10	3600	3300	5500	≤19	0.11	102	51	25	34	3	22	70.0	15	6.6	16	6.6	28	13	577	232
215.4	ZV322S_K403_2150 ME20	3600	3300	5500	≤24	0.09	102	51	25	34	3	22	70.0	12	6.6	15	6.6	24	13	508	232
218.2	ZV322S_K403_2180 ME10	3600	3300	5500	≤19	0.09	102	51	25	34	3	22	70.0	12	6.6	15	6.6	24	13	508	232
271.6	ZV322S_K403_2720 ME10	3600	3300	5500	≤19	0.07	102	51	25	34	3	22	70.0	11	6.6	13	6.6	21	13	445	232
ZV4K4 (F_{v2acc,max} = 15 kN)																					
4.000	ZV418S_K402_0040 ME30	2600	2200	3800	≤38	3.80	111	44	17	33	4	18	76.4	8.0	6.9	12	6.9	20	14	459	265
4.000	ZV418S_K402_0040 ME40	2600	2200	3800	≤48	3.80	111	44	17	33	4	18	76.4	8.0	6.9	12	6.9	20	14	459	265
4.364	ZV418S_K402_0044 ME30	2600	2200	3800	≤38	3.48	111	44	17	33	4	18	76.4	8.2</							

12.2 Selection tables 12 ZVK rack and pinion drives

i	Type	n _{1maxDB}		n _{1maxZV}	d _{MW}	v _{zmaxZB}	Δs	Δs _{redll}	Δs _{redl}	C _{lin}	m _n	z	d ₀	F _{zN,S}	F _{zN,E}	F _{zaccS}	F _{zaccE}	F _{zNOT,S}	F _{zNOT,E}	M _{zaccS}	M _{zaccE}
		EL1,2 [rpm]	EL3,4,5,6 [rpm]																		
ZV4K4 (F_{v2acc,max} = 15 kN)																					
5.422	ZV418S_K402_0054 ME40	2600	2200	3800	≤48	2.80	111	44	17	34	4	18	76.4	8.9	6.9	13	6.9	28	14	508	265
6.000	ZV418S_K402_0060 ME30	2600	2200	3800	≤38	2.53	111	44	17	34	4	18	76.4	9.2	6.9	14	6.9	29	14	525	265
6.000	ZV418S_K402_0060 ME40	2600	2200	3800	≤48	2.53	111	44	17	34	4	18	76.4	9.2	6.9	14	6.9	29	14	525	265
6.719	ZV418S_K402_0067 ME20	3000	2600	4500	≤32	2.68	111	44	17	33	4	18	76.4	9.5	6.9	10	6.9	13	13	391	265
6.719	ZV418S_K402_0067 ME30	3000	2600	4500	≤38	2.68	111	44	17	34	4	18	76.4	9.5	6.9	14	6.9	29	14	545	265
6.719	ZV418S_K402_0067 ME40	3000	2600	4500	≤48	2.68	111	44	17	34	4	18	76.4	9.5	6.9	14	6.9	29	14	545	265
7.456	ZV418S_K402_0075 ME30	2600	2200	3800	≤38	2.04	111	44	17	34	4	18	76.4	9.9	6.9	15	6.9	29	14	564	265
7.456	ZV418S_K402_0075 ME40	2600	2200	3800	≤48	2.04	111	44	17	34	4	18	76.4	9.9	6.9	15	6.9	29	14	564	265
8.377	ZV418S_K402_0084 ME20	3000	2600	4500	≤32	2.15	111	44	17	34	4	18	76.4	10	6.9	13	6.9	16	14	488	265
8.377	ZV418S_K402_0084 ME30	3000	2600	4500	≤38	2.15	111	44	17	34	4	18	76.4	10	6.9	15	6.9	29	14	573	265
8.377	ZV418S_K402_0084 ME40	3000	2600	4500	≤48	2.15	111	44	17	34	4	18	76.4	10	6.9	15	6.9	29	14	573	265
9.238	ZV418S_K402_0092 ME20	3000	2600	4500	≤32	1.95	111	44	17	34	4	18	76.4	11	6.9	14	6.9	18	14	538	265
9.238	ZV418S_K402_0092 ME30	3000	2600	4500	≤38	1.95	111	44	17	34	4	18	76.4	11	6.9	15	6.9	29	14	573	265
9.238	ZV418S_K402_0092 ME40	3000	2600	4500	≤48	1.95	111	44	17	34	4	18	76.4	11	6.9	15	6.9	29	14	573	265
10.10	ZV418S_K402_0100 ME20	3400	3000	5000	≤32	1.98	111	44	17	34	4	18	76.4	11	6.9	15	6.9	19	14	573	265
10.10	ZV418S_K402_0100 ME30	3400	3000	5000	≤38	1.98	111	44	17	34	4	18	76.4	11	6.9	15	6.9	29	14	573	265
10.10	ZV418S_K402_0100 ME40	3000	3000	4500	≤48	1.78	111	44	17	34	4	18	76.4	11	6.9	15	6.9	29	14	573	265
11.52	ZV418S_K402_0115 ME20	3000	2600	4500	≤32	1.56	111	44	17	34	4	18	76.4	11	6.9	15	6.9	22	14	573	265
11.52	ZV418S_K402_0115 ME30	3000	2600	4500	≤38	1.56	111	44	17	34	4	18	76.4	11	6.9	15	6.9	29	14	573	265
11.52	ZV418S_K402_0115 ME40	3000	2600	4500	≤48	1.56	111	44	17	34	4	18	76.4	11	6.9	15	6.9	29	14	573	265
12.66	ZV418S_K402_0125 ME20	3400	3000	5000	≤32	1.58	111	44	17	34	4	18	76.4	12	6.9	15	6.9	23	14	573	265
12.66	ZV418S_K402_0125 ME30	3400	3000	5000	≤38	1.58	111	44	17	34	4	18	76.4	12	6.9	15	6.9	29	14	573	265
12.66	ZV418S_K402_0125 ME40	3000	3000	4500	≤48	1.42	111	44	17	34	4	18	76.4	12	6.9	15	6.9	29	14	573	265
13.89	ZV418S_K402_0140 ME20	3400	3000	5000	≤32	1.44	111	44	17	34	4	18	76.4	12	6.9	15	6.9	26	14	573	265
13.89	ZV418S_K402_0140 ME30	3400	3000	5000	≤38	1.44	111	44	17	34	4	18	76.4	12	6.9	15	6.9	29	14	573	265
13.89	ZV418S_K402_0140 ME40	3000	3000	4500	≤48	1.30	111	44	17	34	4	18	76.4	12	6.9	15	6.9	29	14	573	265
16.94	ZV418S_K402_0170 ME20	3600	3300	5500	≤32	1.30	111	44	17	34	4	18	76.4	13	6.9	15	6.9	27	14	573	265
16.94	ZV418S_K402_0170 ME30	3500	3300	5000	≤38	1.18	111	44	17	34	4	18	76.4	13	6.9	15	6.9	29	14	573	265
16.94	ZV418S_K402_0170 ME40	3000	3000	4500	≤48	1.06	111	44	17	34	4	18	76.4	13	6.9	15	6.9	29	14	573	265
17.41	ZV418S_K402_0175 ME20	3400	3000	5000	≤32	1.15	111	44	17	34	4	18	76.4	13	6.9	15	6.9	29	14	573	265
17.41	ZV418S_K402_0175 ME30	3400	3000	5000	≤38	1.15	111	44	17	34	4	18	76.4	13	6.9	15	6.9	29	14	573	265
17.41	ZV418S_K402_0175 ME40	3000	3000	4500	≤48	1.03	111	44	17	34	4	18	76.4	13	6.9	15	6.9	29	14	573	265
20.20	ZV418S_K402_0200 ME20	3600	3300	5500	≤32	1.09	111	44	17	34	4	18	76.4	14	6.9	15	6.9	29	14	573	265
20.20	ZV418S_K402_0200 ME30	3500	3300	5000	≤38	0.99	111	44	17	34	4	18	76.4	14	6.9	15	6.9	29	14	573	265
23.29	ZV418S_K402_0230 ME20	3600	3300	5500	≤32	0.95	111	44	17	34	4	18	76.4	14	6.9	15	6.9	29	14	573	265
23.29	ZV418S_K402_0230 ME30	3500	3300	5000	≤38	0.86	111	44	17	34	4	18	76.4	14	6.9	15	6.9	29	14	573	265
23.29	ZV418S_K402_0230 ME40	3000	3000	4500	≤48	0.77	111	44	17	34	4	18	76.4	14	6.9	15	6.9	29	14	573	265
25.28	ZV418S_K402_0250 ME20	3600	3300	5500	≤32	0.87	111	44	17	34	4	18	76.4	13	6.9	15	6.9	26	14	573	265
25.28	ZV418S_K402_0250 ME30	3500	3300	5000	≤38	0.79	111	44	17	34	4	18	76.4	13	6.9	15	6.9	26	14	573	265
27.77	ZV418S_K402_0280 ME20	3600	3300	5500	≤32	0.79	111	44	17	34	4	18	76.4	14	6.9	15	6.9	29	14	573	265
27.77	ZV418S_K402_0280 ME30	3500	3300	5000	≤38	0.72	111	44	17	34	4	18	76.4	14	6.9	15	6.9	29	14	573	265
32.39	ZV418S_K403_0320 ME20	3600	3300	5500	≤24	0.68	111	56	28	34	4	18	76.4	12	6.9	12	6.9	15	14	462	265
33.68	ZV418S_K402_0340 ME20	3600	3300	5500	≤24	0.65	111	44	17	34	4	18	76.4	10	6.9	12	6.9	19	14	467	265
34.76	ZV418S_K402_0350 ME20	3600	3300	5500	≤32	0.63	111	44	17	34	4	18	76.4	14	6.9	15	6.9	29	14	573	265
34.76	ZV418S_K402_0350 ME30	3500	3300	5000	≤38	0.58	111	44	17	34	4	18	76.4	14	6.9	15	6.9	29	14	573	265
35.72	ZV418S_K403_0360 ME20	3600	3300	5500	≤24	0.62	111	56	28	34	4	18	76.4	13	6.9	13	6.9	17	14	509	265
39.05	ZV418S_K403_0390 ME20	3600	3300	5500	≤24	0.56	111	56	28	34	4	18	76.4	14	6.9	15	6.9	18	14	557	265
40.51	ZV418S_K402_0410 ME20	3600	3300	5500	≤24	0.54	111	44	17	34	4	18	76.4	8.1	6.9	9.7	6.9	16	14	370	265
44.54	ZV418S_K403_0450 ME20	3600	3300	5500	≤24	0.49	111	56	28	34	4	18	76.4	14	6.9	15	6.9	21	14	573	265
46.31	ZV418S_K402_0460 ME20	3600	3300	5500	≤24	0.48	111	44	17	34	4	18	76.4	14	6.9	15	6.9	26	14	573	265
48.94	ZV418S_K403_0490 ME20	3600	3300	5500	≤24	0.45	111	56	28	34	4	18	76.4	14	6.9	15	6.9	23	14	573	265
50.43	ZV418S_K402_0500 ME20	3600	3300	5500	≤24	0.44	111	44	17	34	4	18	76.4	7.1	6.9	8.5	6.9	14	14	323	265
53.69	ZV418S_K403_0540 ME20	3600	3300	5500	≤24	0.41	111	56	28	34	4	18	76.4	14	6.9	15	6.9	25	14	573	265
55.71	ZV418S_K402_0560 ME20	3600	3300	5500	≤24	0.40	111	44	17	34	4	18	76.4	11	6.9	13	6.9	22	14	508	265
65.50	ZV418S_K403_0650 ME20	3600	3300	5500	≤24	0.34	111	56	28	34	4	18	76.4	14	6.9	15	6.9	27	14	573	265
66.35	ZV418S_K403_0660 ME10	3600	3300	5500	≤19	0.33	111	56	28	34	4	18	76.4	8.9	6.9	8.9	6.9	11	11	340	265
67.30	ZV418S_K403_0670 ME20	3600	3300	5500	≤24	0.33	111	56	28	34	4	18	76.4	14	6.9	15	6.9	29	14	573	265
69.34	ZV418S_K402_0690 ME20	3600	3300	5500	≤24	0.32	111	44	17	34	4	18	76.4	9.7	6.9	12	6.9	19	14	445	265
78.10	ZV418S_K403_0780 ME20	3600	3300	5500	≤24	0.28	111	56	28	34	4	18	76.4	14	6.9	15	6.9	29	14	573	265
79.11	ZV418S_K403_0790 ME10	3600	3300	5500	≤19	0.28	111	56	28	34	4	18	76.4	11	6.9	11	6.9	13	13	406	265
90.06	ZV418S_K403_0900 ME20	3600	3300	5500	≤24	0.24	111	56	28	34	4	18	76.4	14	6.9	15	6.9	29	14	573	265
91.23	ZV418S_K403_0910 ME10	3600	3300	5500	≤19	0.24	111	56	28	34	4	18	76.4	1							

i	Type	n_{1maxDB}		n_{1maxZV}	d_{MW}	$v_{f2maxZB}$	Δs	Δs_{redII}	Δs_{redI}	C_{lin}	m_n	z	d_0	$F_{f2N,S}$	$F_{f2N,E}$	F_{f2accS}	F_{f2accE}	$F_{f2NOT,S}$	$F_{f2NOT,E}$	M_{2accS}	M_{2accE}
		EL1,2 [rpm]	EL3,4,5,6 [rpm]																		
ZV4K4 ($F_{v2acc,max} = 15 \text{ kN}$)																					
134.4	ZV418S_K403_1340 ME20	3600	3300	5500	≤24	0.16	111	56	28	34	4	18	76.4	14	6.9	15	6.9	29	14	573	265
136.1	ZV418S_K403_1360 ME10	3600	3300	5500	≤19	0.16	111	56	28	34	4	18	76.4	14	6.9	15	6.9	21	14	573	265
179.1	ZV418S_K403_1790 ME20	3600	3300	5500	≤24	0.12	111	56	28	34	4	18	76.4	14	6.9	15	6.9	26	14	573	265
181.4	ZV418S_K403_1810 ME10	3600	3300	5500	≤19	0.12	111	56	28	34	4	18	76.4	14	6.9	15	6.9	26	14	573	265
215.4	ZV418S_K403_2150 ME20	3600	3300	5500	≤24	0.10	111	56	28	34	4	18	76.4	11	6.9	13	6.9	22	14	508	265
218.2	ZV418S_K403_2180 ME10	3600	3300	5500	≤19	0.10	111	56	28	34	4	18	76.4	11	6.9	13	6.9	22	14	508	265
271.6	ZV418S_K403_2720 ME10	3600	3300	5500	≤19	0.08	111	56	28	34	4	18	76.4	9.7	6.9	12	6.9	19	14	445	265

12.3 Dimensional drawings

In this chapter, you can find the dimensions of the rack and pinion drives with motor adapter.

Dimension a_z in the tables of dimensions applies to STOBBER gear racks. In general: $a_z = \frac{1}{2} d_0 + h_0 + x \cdot m_n$

The pinion of the rack and pinion drive is helical (left-hand $19^\circ 31' 42''$). The pinion gearing quality is 6.

Dimensions can exceed the specifications of ISO 2768-mK due to casting tolerances or accumulation of individual tolerances.

We reserve the right to make dimensional changes due to ongoing technical development.

You can download 3D models of our standard drives at <https://configurator.stoeber.de/en-US/>.

12.3.1 Pinion position E

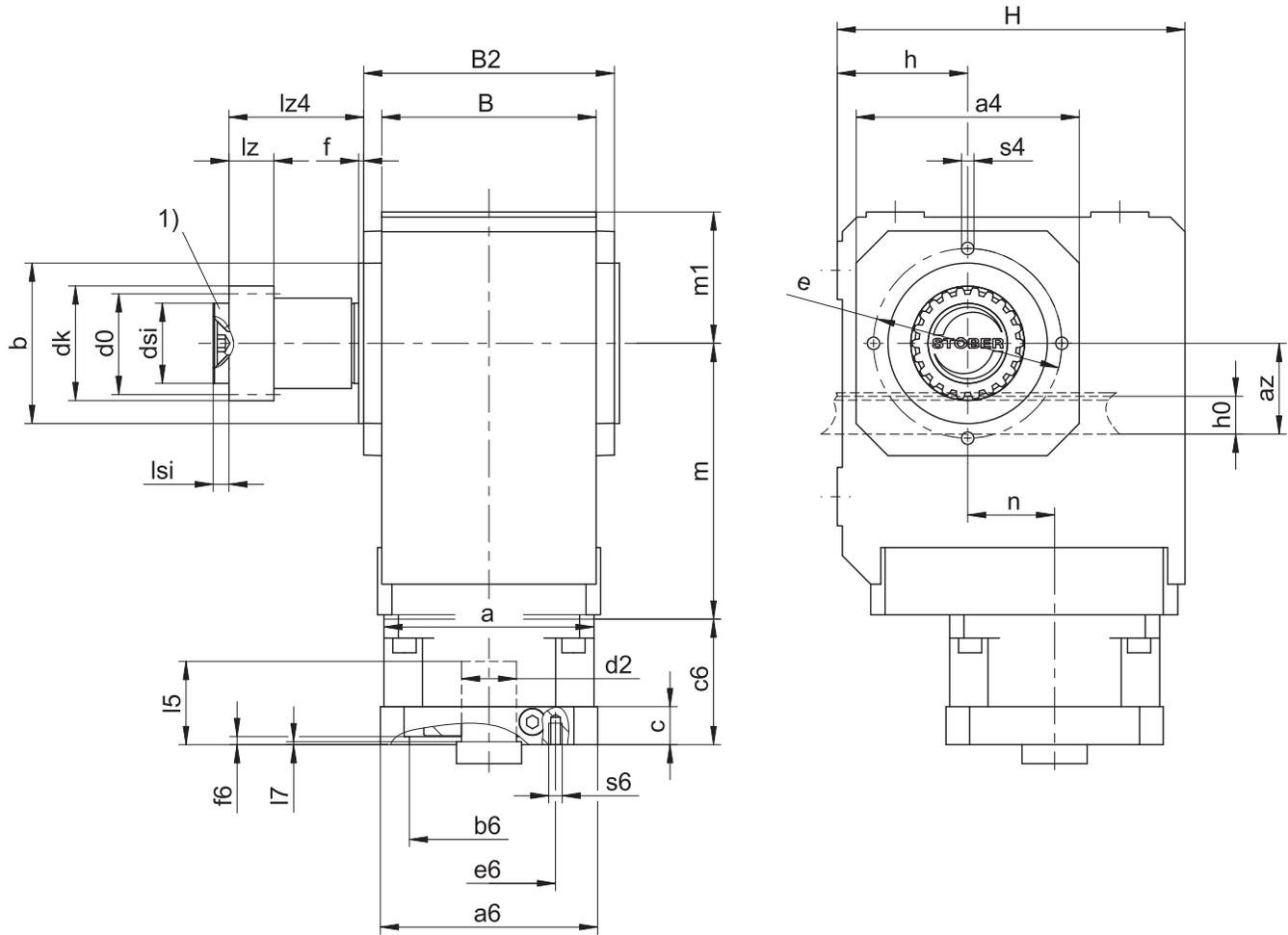

1) Axial locking (optional)

Output dimensions

Type	mn	az	□a4	Øb	B	B2	Ød0	Ødk	Ødsi	Øe	f	h	h0	H	lz	lz4	l _{si}	m1	s4	x
ZV220SEK102_	2	44.02	105	75 _β	90	106	42.44	47.90	30	90	3.0	60	22	160	26	50.5	6	60	M8	0.4
ZV225SEK202_	2	49.33	116	82 _β	115	134	53.05	58.52	45	100	3.0	65	22	190	26	67.5	8	65	M8	0.4
ZV225SEK203_	2	49.33	116	82 _β	115	134	53.05	58.52	45	100	3.0	65	22	190	26	67.5	8	65	M8	0.4
ZV318SEK202_	3	55.55	116	82 _β	115	134	57.30	65.01	45	100	3.0	65	26	190	31	67.5	8	65	M8	0.3
ZV318SEK203_	3	55.55	116	82 _β	115	134	57.30	65.01	45	100	3.0	65	26	190	31	67.5	8	65	M8	0.3
ZV225SEK302_	2	49.33	132	95 _β	130	146	53.05	58.52	45	115	3.0	75	22	213	26	68.5	8	75	M8	0.4
ZV225SEK303_	2	49.33	132	95 _β	130	146	53.05	58.52	45	115	3.0	75	22	213	26	68.5	8	75	M8	0.4
ZV318SEK302_	3	55.55	132	95 _β	130	146	57.30	65.01	45	115	3.0	75	26	213	31	68.5	8	75	M8	0.3
ZV318SEK303_	3	55.55	132	95 _β	130	146	57.30	65.01	45	115	3.0	75	26	213	31	68.5	8	75	M8	0.3
ZV322SEK402_	3	62.21	152	110 _β	148	173	70.03	78.35	55	130	3.5	90	26	240	31	93.0	10	90	M10	0.4
ZV322SEK403_	3	62.21	152	110 _β	148	173	70.03	78.35	55	130	3.5	90	26	240	31	93.0	10	90	M10	0.4
ZV418SEK402_	4	74.40	152	110 _β	148	173	76.40	86.77	55	130	3.5	90	35	240	41	93.0	10	90	M10	0.3
ZV418SEK403_	4	74.40	152	110 _β	148	173	76.40	86.77	55	130	3.5	90	35	240	41	93.0	10	90	M10	0.3

Type	ME10			ME20			ME30			ME40		
	a	m	n	a	m	n	a	m	n	a	m	n
ZV2_K102_	□98	124	36.0	□115	128	36.0	–	–	–	–	–	–
ZV2_K202_	□98	143	46.0	□115	147	46.0	□145	149	46.0	–	–	–
ZV2_K203_	∅140	180	46.0	–	–	–	–	–	–	–	–	–
ZV2_K302_	∅140	163	52.5	□115	167	52.5	□145	169	52.5	–	–	–
ZV2_K303_	∅140	200	52.5	∅160	210	16.0	–	–	–	–	–	–
ZV3_K202_	□98	143	46.0	□115	147	46.0	□145	149	46.0	–	–	–
ZV3_K203_	∅140	180	46.0	–	–	–	–	–	–	–	–	–
ZV3_K302_	∅140	163	52.5	□115	167	52.5	□145	169	52.5	–	–	–
ZV3_K303_	∅140	200	52.5	∅160	210	16.0	–	–	–	–	–	–
ZV3_K402_	–	–	–	∅160	187	60.0	□145	189	60.0	□190	192	60.0
ZV3_K403_	∅140	220	60.0	∅160	230	23.0	–	–	–	–	–	–
ZV4_K402_	–	–	–	∅160	187	60.0	□145	189	60.0	□190	192	60.0
ZV4_K403_	∅140	220	60.0	∅160	230	23.0	–	–	–	–	–	–

Example dimensions for the motor connection

Type	∅b6	∅e6	∅d2max	l5	□a6	c	c6	f6	l7	s6
ME10	95 ^{H7}	115	19	41	100	21	61	4.0	3.0	M8
ME20	110 ^{H7}	130	32	53	120	24	74	4.0	3.5	M8
ME30	130 ^{H7}	165	38	62	150	26	86	5.5	4.5	M10
ME40	180 ^{H7}	215	48	82	204	35	123	5.5	5.5	M12

In the table above, you will find example dimensions for the motor connection for the ME motor adapter.

Note that when dimension c is lengthened, dimensions c6 and l5 are also lengthened accordingly.

You will find additional motor connection dimensions for the ME motor adapter in our STÖBER Configurator at <https://configurator.stoeber.de/en-US/>. Here, you can directly download a 3D model of your drive.

12.3.2 Pinion position S

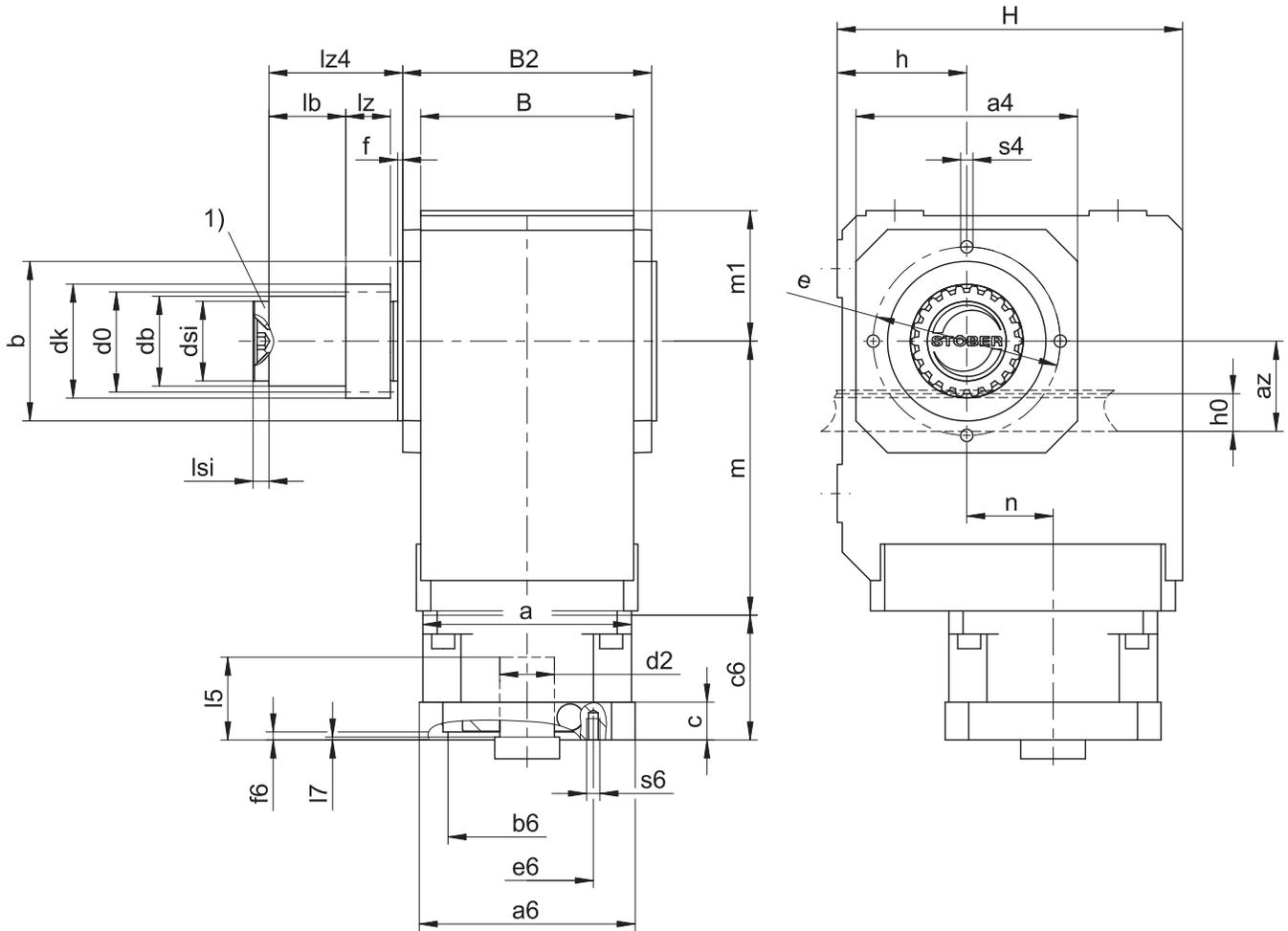

1) Axial locking (optional)

Output dimensions

Type	mn	az	□a4	Øb	B	B2	Ød0	Ødb	Ødk	Ødsi	Øe	f	h	h0	H	lb	lz	lz4	lsi	m1	Øs4	x
ZV220SSK102_	2	44.02	105	75 _{f6}	90	106	42.44	38	47.90	30	90	3.0	60	22	160	12.5	26	50.5	6	60	M8	0.4
ZV225SSK202_	2	49.33	116	82 _{f6}	115	134	53.05	50	58.52	45	100	3.0	65	22	190	34.5	26	67.5	8	65	M8	0.4
ZV225SSK203_	2	49.33	116	82 _{f6}	115	134	53.05	50	58.52	45	100	3.0	65	22	190	34.5	26	67.5	8	65	M8	0.4
ZV318SSK202_	3	55.55	116	82 _{f6}	115	134	57.30	50	65.01	45	100	3.0	65	26	190	29.5	31	67.5	8	65	M8	0.3
ZV318SSK203_	3	55.55	116	82 _{f6}	115	134	57.30	50	65.01	45	100	3.0	65	26	190	29.5	31	67.5	8	65	M8	0.3
ZV225SSK302_	2	49.33	132	95 _{f6}	130	146	53.05	50	58.52	45	115	3.0	75	22	213	34.5	26	68.5	8	75	M8	0.4
ZV225SSK303_	2	49.33	132	95 _{f6}	130	146	53.05	50	58.52	45	115	3.0	75	22	213	34.5	26	68.5	8	75	M8	0.4
ZV318SSK302_	3	55.55	132	95 _{f6}	130	146	57.30	50	65.01	45	115	3.0	75	26	213	29.5	31	68.5	8	75	M8	0.3
ZV318SSK303_	3	55.55	132	95 _{f6}	130	146	57.30	50	65.01	45	115	3.0	75	26	213	29.5	31	68.5	8	75	M8	0.3
ZV322SSK402_	3	62.21	152	110 _{f6}	148	173	70.03	62	78.35	55	130	3.5	90	26	240	53.5	31	93.0	10	90	M10	0.4
ZV322SSK403_	3	62.21	152	110 _{f6}	148	173	70.03	62	78.35	55	130	3.5	90	26	240	53.5	31	93.0	10	90	M10	0.4
ZV418SSK402_	4	74.40	152	110 _{f6}	148	173	76.40	62	86.77	55	130	3.5	90	35	240	43.5	41	93.0	10	90	M10	0.3
ZV418SSK403_	4	74.40	152	110 _{f6}	148	173	76.40	62	86.77	55	130	3.5	90	35	240	43.5	41	93.0	10	90	M10	0.3

Type	ME10			ME20			ME30			ME40		
	a	m	n	a	m	n	a	m	n	a	m	n
ZV2_K102_	□98	124	36.0	□115	128	36.0	–	–	–	–	–	–
ZV2_K202_	□98	143	46.0	□115	147	46.0	□145	149	46.0	–	–	–
ZV2_K203_	∅140	180	46.0	–	–	–	–	–	–	–	–	–
ZV2_K302_	∅140	163	52.5	□115	167	52.5	□145	169	52.5	–	–	–
ZV2_K303_	∅140	200	52.5	∅160	210	16.0	–	–	–	–	–	–
ZV3_K202_	□98	143	46.0	□115	147	46.0	□145	149	46.0	–	–	–
ZV3_K203_	∅140	180	46.0	–	–	–	–	–	–	–	–	–
ZV3_K302_	∅140	163	52.5	□115	167	52.5	□145	169	52.5	–	–	–
ZV3_K303_	∅140	200	52.5	∅160	210	16.0	–	–	–	–	–	–
ZV3_K402_	–	–	–	∅160	187	60.0	□145	189	60.0	□190	192	60.0
ZV3_K403_	∅140	220	60.0	∅160	230	23.0	–	–	–	–	–	–
ZV4_K402_	–	–	–	∅160	187	60.0	□145	189	60.0	□190	192	60.0
ZV4_K403_	∅140	220	60.0	∅160	230	23.0	–	–	–	–	–	–

Example dimensions for the motor connection

Type	∅b6	∅e6	∅d2max	l5	□a6	c	c6	f6	l7	s6
ME10	95 ^{H7}	115	19	41	100	21	61	4.0	3.0	M8
ME20	110 ^{H7}	130	32	53	120	24	74	4.0	3.5	M8
ME30	130 ^{H7}	165	38	62	150	26	86	5.5	4.5	M10
ME40	180 ^{H7}	215	48	82	204	35	123	5.5	5.5	M12

In the table above, you will find example dimensions for the motor connection for the ME motor adapter.

Note that when dimension c is lengthened, dimensions c6 and l5 are also lengthened accordingly.

You will find additional motor connection dimensions for the ME motor adapter in our STÖBER Configurator at <https://configurator.stoeber.de/en-US/>. Here, you can directly download a 3D model of your drive.

12.4 Type designation

In this chapter, you can find an explanation of the type designation with the associated options.

Additional ordering information not included in the type designation can be found at the end of the chapter.

Example code

Z	V	3	22	S	S	K	4	0	2	V	G	0084	ME30
---	---	---	----	---	---	---	---	---	---	---	---	------	------

Explanation

Code	Designation	Design
Z	Type	Rack and pinion drive
V	Design	Plug-on pinion
3	Normal module	$m_n = 3$ mm (example)
22	Number of teeth	$z = 22$ (example)
S	Toothing	Helical (left-hand 19° 31' 42")
E	Pinion position	Shaft end
S		Shaft shoulder
K	Type	Helical bevel gear unit
4	Size	4 (example)
0	Generation	Generation 0
1		Generation 1
2	Stages	Two-stage
3		Three-stage
V	Shaft	Solid shaft
G	Housing	Pitch circle diameter
0084	Transmission ratio (i x 10 rounded)	$i = 8.377$ (example)
ME30	Motor adapter	ME30 motor adapter (example) with EasyAdapt coupling
MQ		Square motor adapter with backlash-free plug-in coupling
MB ¹		ServoStop motor adapter with brake

To complete the type designation, also specify the following in your order:

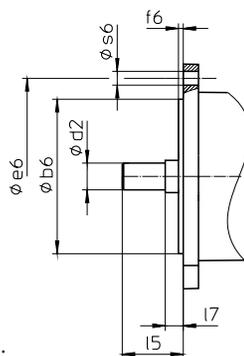

- Motor type or motor dimensions:

To choose a suitable motor connection, use the STOBBER Configurator at

<https://configurator.stoeber.de/en-US/> and choose your motor or the dimensions of the motor connection.

- Mounting position, see the chapter [▶ 12.5.6]
- Attachment of solid shaft: gear unit side 3 or 4
- Pitch circle diameter: gear unit side 3 or 4
- Backlash: Standard/class II/class I. Backlash class II and class I for an additional charge.
- For axial locking (optional), see the chapter [▶ 12.3]
- Position of locking screw access, see the chapter [▶ 12.5.8]
- ZV_K102_, ZV_K202_, ZV_K302_, ZV_K402_: Pinion lock for motor adapter (optional)
- Double seal for ME motor adapter (optional)

An explanation of the gear unit sides can be found in the chapter [▶ 12.5.6]

In this product catalog, you will find all the information about rack and pinion drives with a motor adapter. All input options available upon request are listed in the chapter [▶ 12.5.1].

12.4.1 Nameplate

An example gear unit nameplate is explained in the figure below.

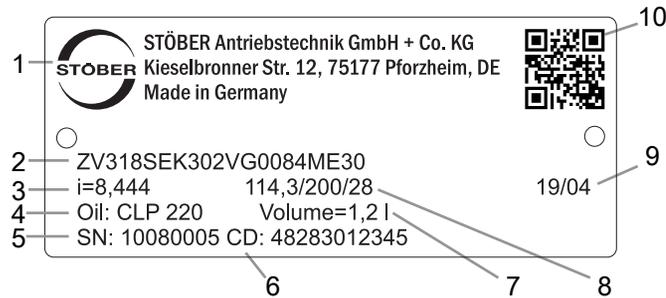

Code	Designation
1	Name of manufacturer
2	Type designation
3	Gear ratio of the gear unit
4	Lubricant specification
5	Serial number of the gear unit
6	Customer-specific data
7	Lubricant fill volume
8	Dimensions of the motor adapter
9	Date of manufacture (year/calendar week)
10	QR code (link to product information)

12.4.1.1 Supporting documents

You can view or download supporting documents for the product by reading off the serial number on the nameplate of the product and entering it at the following address online:

<https://id.stober.com>

Alternatively, you can use a suitable mobile device to scan in the QR code on the nameplate of the product in order to be linked to the supporting documents.

12.5 Product description

12.5.1 Input options

This chapter shows you all available input options:

ME motor adapter

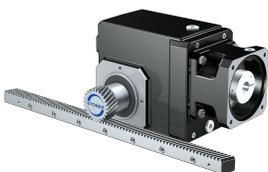

Catalog ID 443137_en

EZ synchronous servo motor



Catalog ID 443286_en

MB motor adapter



On request

LM Lean motor



On request

The corresponding catalogs can be found at <http://www.stober.de/en/downloads/>

Enter the ID of the catalog in the Search term field.

You can also acquire rack and pinion drives with low-backlash K gear units on request. To do so, send us an e-mail at sales@stober.de.

12.5.2 Motor adapter with EasyAdapt coupling (ME)

In this chapter, you will find a description of the EasyAdapt coupling.

Properties:

- Fast and easy motor attachment
- Rugged, patented clamp coupling with expanding function
- Lowest mass moments of inertia for the highest dynamics
- Balanced for smooth running without vibration, even at high speeds
- Large selection of motor shaft diameters and lengths
- Error-free, thanks to exact centering of the motor



Fig. 1: EasyAdapt coupling

12.5.3 Square motor adapter with backlash-free plug-in coupling (MQ)

In this chapter, you will find a description of the backlash-free plug-in coupling (jaw coupling).

Properties:

- Fast and easy motor attachment
- Removal of the motor possible in any position
- With integrated thermal length compensation, compensates for linear expansion of the motor shaft
- Motor shaft decoupled from axial forces
- Balanced for smooth running without vibration, even at high speeds
- Large selection of motor shaft diameters and lengths
- Error-free, thanks to exact centering of the motor



Fig. 2: Backlash-free plug-in coupling

For all technical data and combinations with our gear units, refer to <https://configurator.stoeber.de/en-US/>.

12.5.4 Gear rack

The gear rack used must have a right-hand design (19° 31' 42"); the load capacity must not be exceeded.

When using a STÖBER gear rack, please also observe the project configuration in the chapter [▶ 13.6](#).

12.5.5 Installation conditions

The specified torques and forces only apply when gear units are fastened on the machine side using screws of strength class 10.9. In addition, the gear housings must be adjusted at the pilot. The machine-side fit must be H7.

12.5.6 Mounting positions

The following table shows the standard mounting positions.

The numbers identify the gear unit sides. The mounting position is defined by the gear side facing downwards.

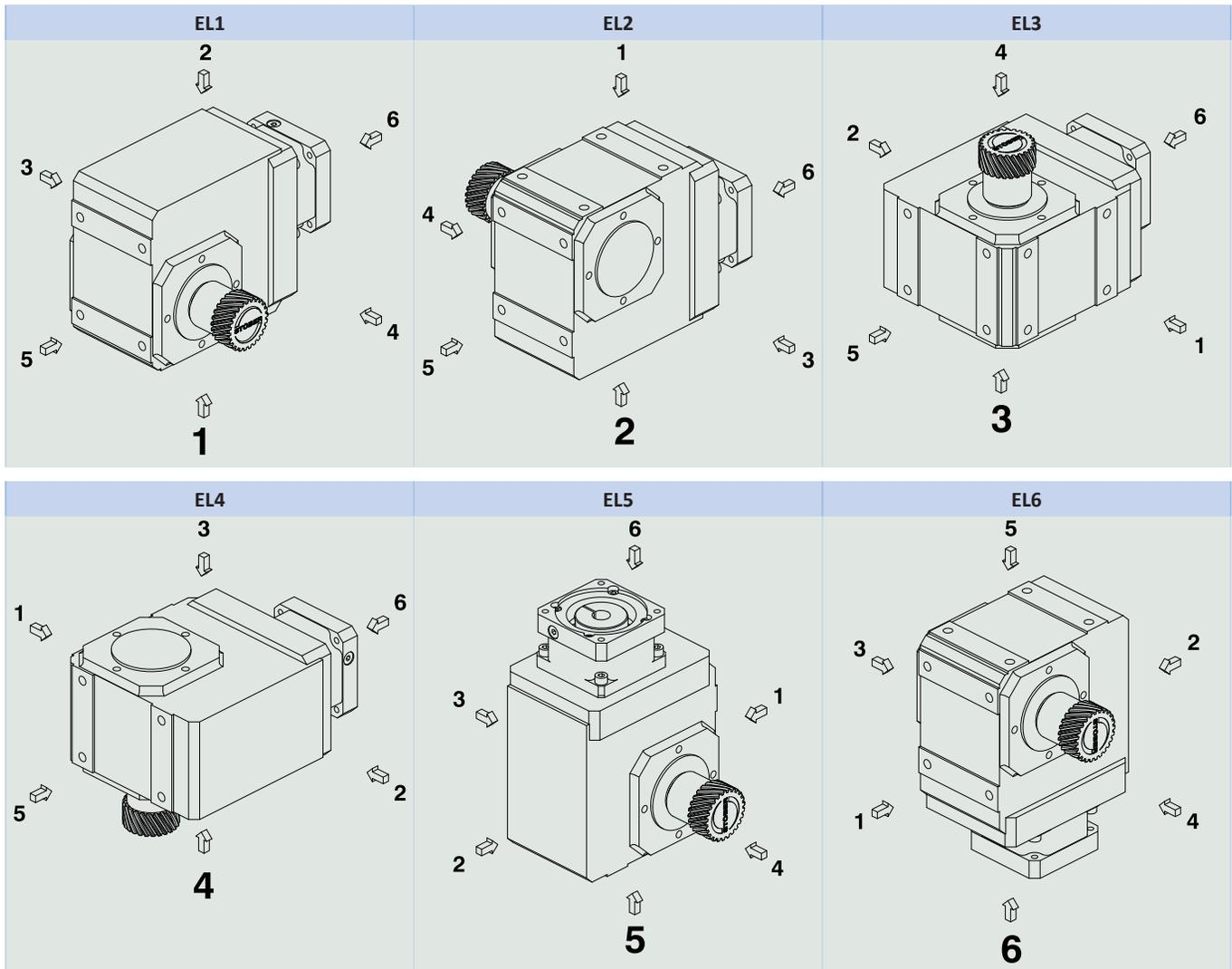

Since the lubricant filling volume of the gear unit depends on the mounting position, the mounting position must be specified when ordering.

12.5.7 Lubricants

STOBER fills the gear units with the amount and type of lubricant specified on the nameplate. The filling volume and the structure of the gear units depend on the mounting position.

Only install the gear units in the intended mounting position! Reposition the gear units only after consulting STOBER. Otherwise, STOBER assumes no liability for the gear units.

You will receive lubricants for use in the food industry upon request.

12.5.7.1 Rack and pinion drive lubrication

Ensure permanent lubrication with the lubricants recommended in the chapter [\[13.5.1 \]](#).

12.5.8 Position of locking screw access

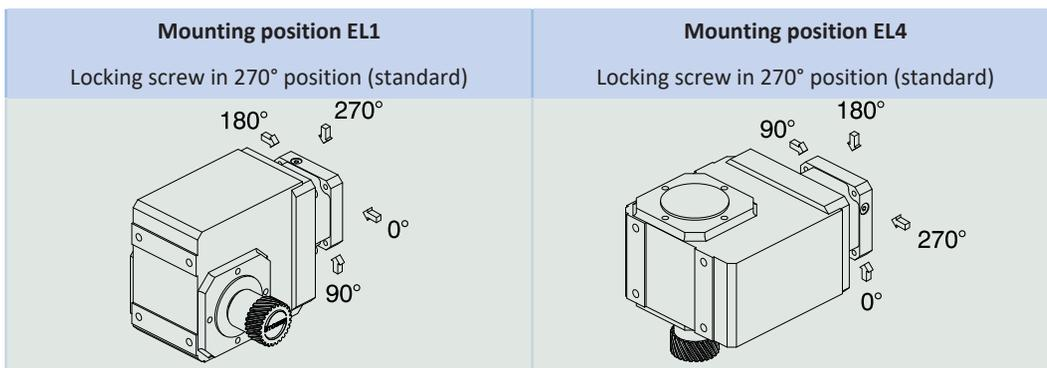

Indicate variations for your gear unit in the order.

Note that the access hole for the locking screw also rotates when the gear unit is rotated to another mounting position.

12.5.9 Other product features

Feature	Value
Max. permitted gear unit temperature (on the surface of the gear unit)	≤ 80 °C
Paint	Black RAL 9005
(ATEX) Directive 2014/34/EU (optional)	Not suitable.
Protection class: ²	
Planetary gear unit	IP65
Pinion/gear rack	IPXX

12.5.10 Direction of rotation

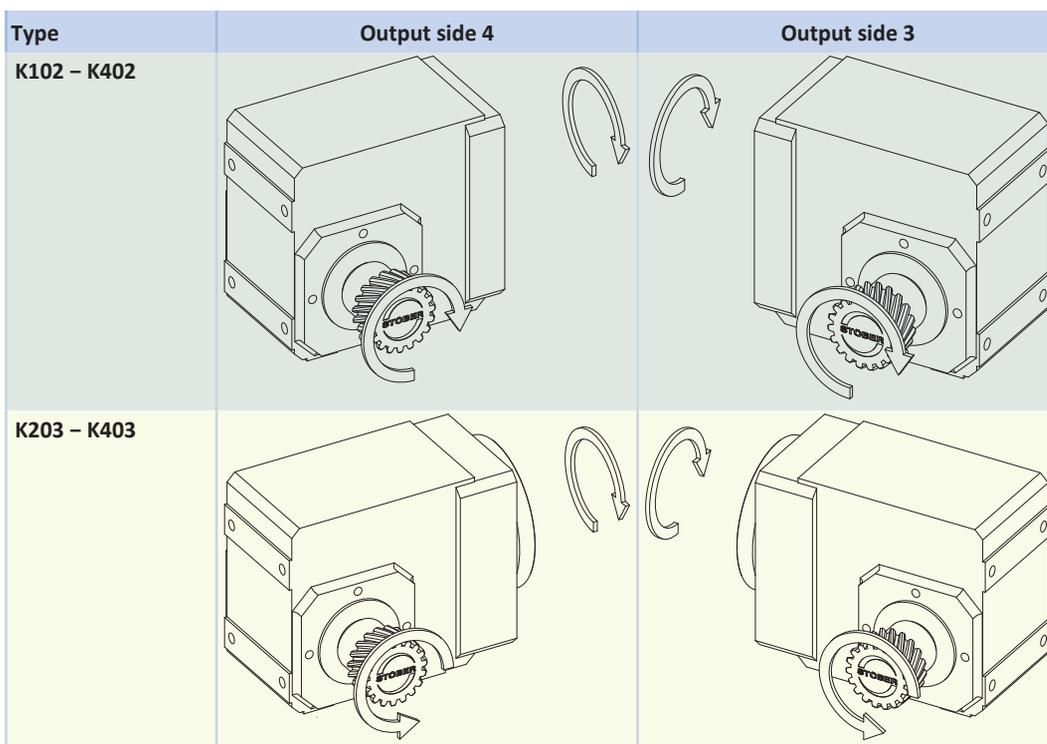

The pictures show mounting position EL1.

²Observe the protection class of all the components.

12.6 Project configuration

Project your drives using our SERVOfsoft designing software. Download SERVOfsoft free of charge after registration at <https://www.stoeber.de/en/services/info-servosoft/>.

It is the most convenient and reliable method of drive selection, as the entire torque/speed curve of the application is displayed and evaluated here in the curve of the geared motor.

In this chapter, only limit values for specific operating points can be taken into consideration for manual drive selection.

The formula symbols for values actually present in the application are marked with *.

An explanation of the formula symbols can be found in the chapter [▶ 14.1](#).

12.6.1 Drive selection

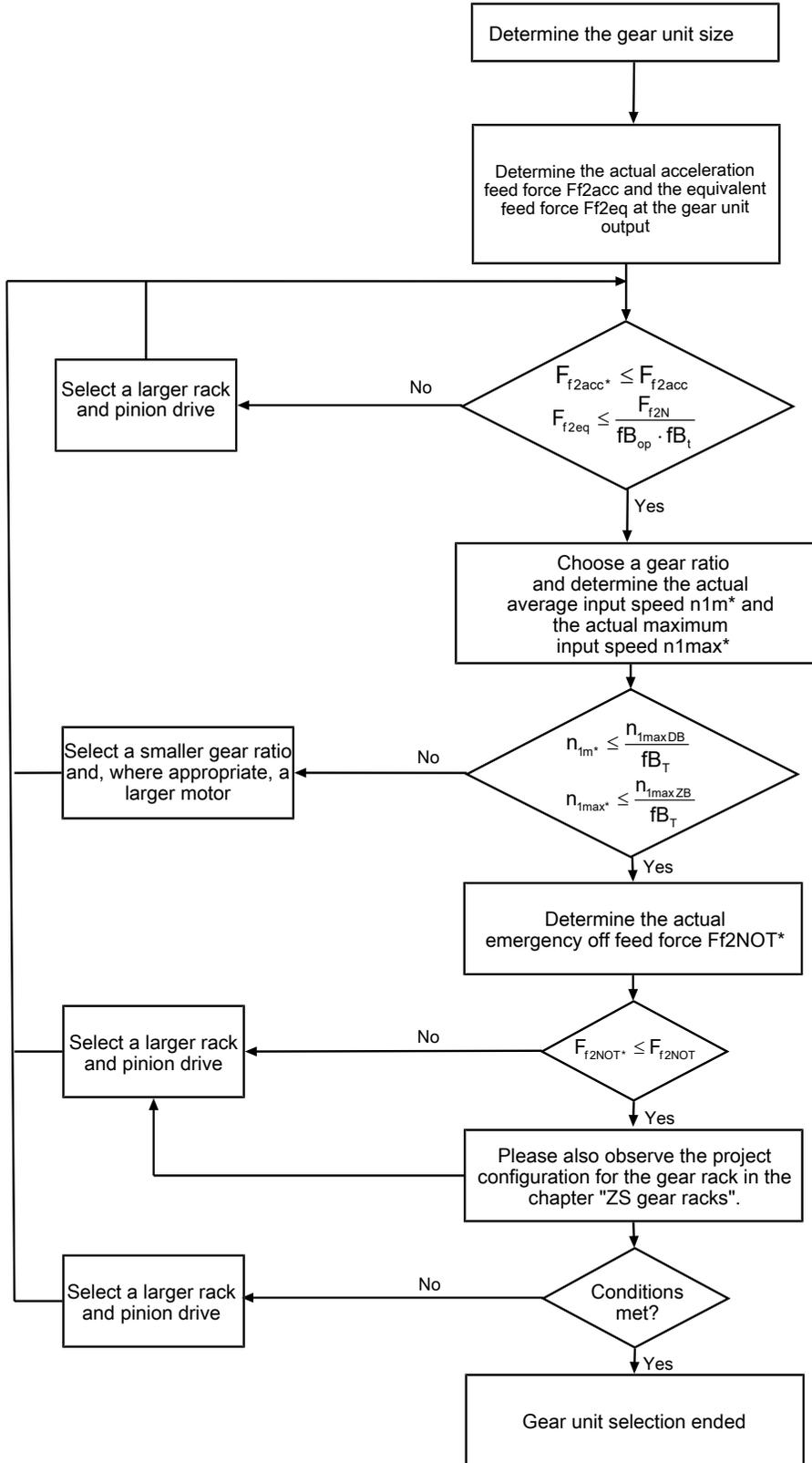

Refer to the selection tables for the values for i , n_{1maxDB} , n_{1maxZB} , F_{f2acc} , F_{f2N} and F_{f2NOT} . The forces depend on the pinion position (E or S). The speeds are partially dependent on the mounting position.

The values for fb_T , fb_{op} and fb_t can be found in the corresponding tables in this chapter.

Example of cyclic operation

The following calculations are based on a representation of the power taken from the output based in accordance with the following example:

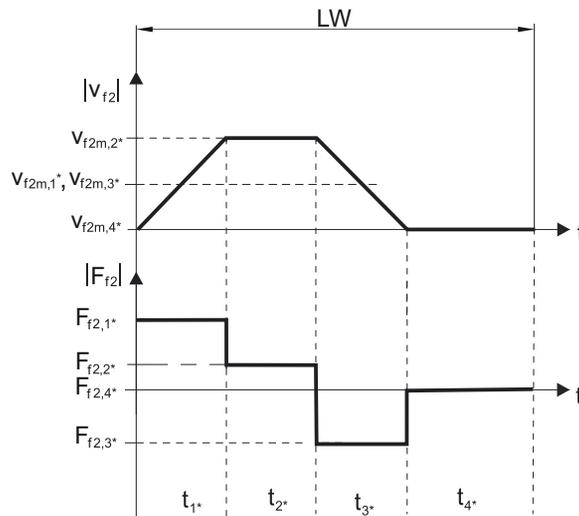

Calculation of the actual maximum acceleration feed force

$$F_{f2acc*} = m \cdot a^* + F_{L*}$$

Calculation of the actual average input speed

$$n_{1m*} = \frac{v_{f2m*} \cdot i}{d_0 \cdot \pi}$$

$$v_{f2m*} = \frac{|v_{f2m,1*}| \cdot t_{1*} + \dots + |v_{f2m,n*}| \cdot t_{n*}}{t_{1*} + \dots + t_{n*}}$$

If $t_{1*} + \dots + t_{3*} \geq 6$ min, determine v_{2m*} without the rest phase t_{4*} .

The values for the ratio i can be found in the selection tables.

Calculation of the actual emergency off feed force

$$F_{f2NOT*} = m \cdot a_{NOT*} + F_{L*}$$

Calculation of the actual equivalent feed force

$$F_{f2eq*} = \sqrt[3]{\frac{|v_{f2m,1*}| \cdot t_{1*} \cdot |F_{f2,1*}|^3 + \dots + |v_{f2m,n*}| \cdot t_{n*} \cdot |F_{f2,n*}|^3}{|v_{f2m,1*}| \cdot t_{1*} + \dots + |v_{f2m,n*}| \cdot t_{n*}}}$$

Operating factors

Operating mode	fB_{op}
Uniform continuous operation	1.00
Cyclic operation	1.25
Reversing load cyclic operation	1.40
Run time	fB_t
Daily runtime ≤ 8 h	1.00
Daily runtime ≤ 16 h	1.15
Daily runtime ≤ 24 h	1.20

Temperature		f_{B_T}
Motor cooling	Surrounding temperature	
Motor with forced ventilation	$\leq 20\text{ }^\circ\text{C}$	0.9
	$\leq 30\text{ }^\circ\text{C}$	1.0
	$\leq 40\text{ }^\circ\text{C}$	1.15
Motor with convection cooling	$\leq 20\text{ }^\circ\text{C}$	1.0
	$\leq 30\text{ }^\circ\text{C}$	1.1
	$\leq 40\text{ }^\circ\text{C}$	1.25

Notes

- The maximum permitted gear unit temperature (see the "Other product features" chapter) must not be exceeded, as that could result in damage.
- For braking from full speed (for example, when the power fails or when setting up the machine), note the permitted gear unit feed forces (F_{f2acc} , F_{f2NOT}) in the selection tables.

12.6.2 Permitted breakdown torques at the gear unit input

For a horizontal mounting position of the motor, verify that the permitted breakdown torque at the gear unit input is not exceeded before installation on a STOEBER gear unit. You can find information for how to do that in this chapter.

Calculate the actual breakdown torque as follows:

$$M_{1k^*} = F_{1k^*} \cdot l_{sp} \leq M_{1k}$$

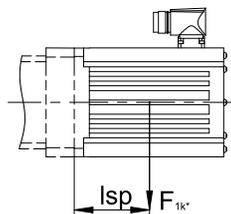

Type	M_{1k} [Nm]
ME10	25
ME20	60
ME30	125
ME40	250
ME50	600

12.7 Additional documentation

Additional documentation related to the product can be found at

<http://www.stoeber.de/en/downloads/>

Enter the ID of the documentation in the Search term field.

Documentation	ID
Operating manual gear units, geared motors K	443364_en
Operating manual gear racks	443392_en

13 ZS gear racks

Table of contents

13.1 Overview	194
13.2 Selection tables	195
13.3 Dimensional drawings	196
13.4 Type designation	197
13.4.1 Nameplate	197
13.5 Product description	197
13.5.1 Lubricants	197
13.5.2 Accessories	198
13.6 Project configuration	199
13.6.1 Drive selection	199
13.6.2 Permitted feed forces depending on the number of pinion teeth	201
13.7 Additional documentation	202

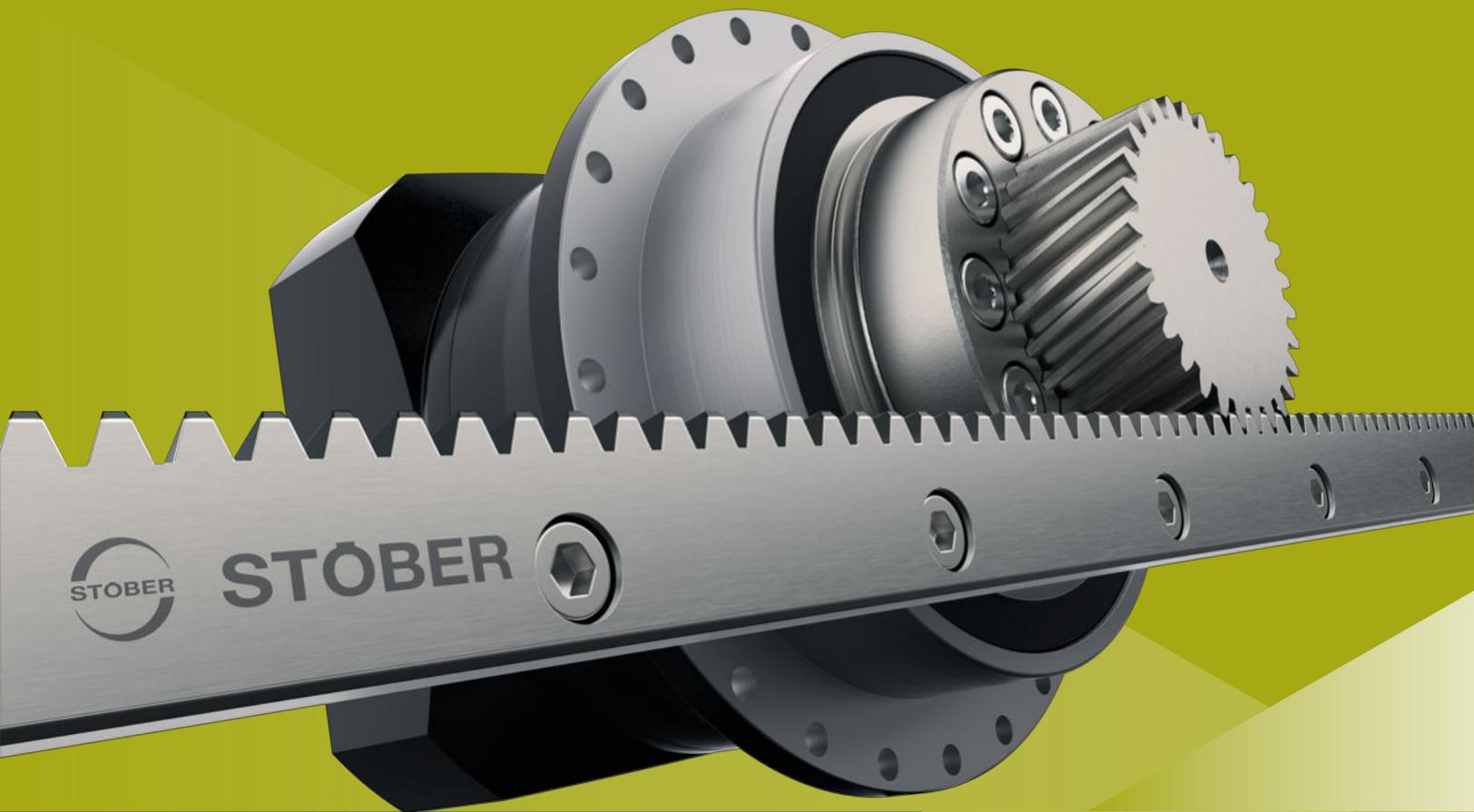

13

Gear racks

ZS

13.1 Overview

Precisely coordinated: Precision gear racks for STÖBER drives

Features

- Helical gearing ✓
- Heat-treatable steel in accordance with STÖBER specification ✓
- Hardened and smoothed ✓
- Gearing quality 6 in accordance with DIN 3962-1 ✓
- Length 500 and 1000 mm ✓

Technical data

m_n	2 – 6 mm
$F_{f,max}$	12.6 – 83.1 kN
F_{sv}	8 – 192.5 kN

13.2 Selection tables

The forces specified in the selection tables applies to:

- De-energized installation
- Permanent lubrication
- Pinion gearing quality at least 6, case-hardened

Please note the gear forces F_f and F_{fNOT} in the chapter [▶ 13.6.2](#), which depend on the number of pinion teeth.

An explanation of the formula symbols can be found in the chapter [▶ 14.1](#).

m_n [mm]	l_{zs} [mm]	Type	$F_{f,max}$ [kN]	F_{sv}			m [kg]
				LA12SPIN [kN]	LA62,5 [kN]	LA62,5PIN [kN]	
2	500.00	ZS2S0500SQ6VG	12.6	8.5	8.0	12.5	1.9
2	1000.00	ZS2S1000SQ6VG	12.6	13.5	18.0	22.0	3.9
3	500.00	ZS3S0500SQ6VG	22.5	16.0	15.5	23.0	2.7
3	1000.00	ZS3S1000SQ6VG	22.5	25.0	33.5	41.0	5.4
4	506.67	ZS4S0500SQ6VG	38.7	31.0	25.0	42.0	5.1
4	1000.00	ZS4S1000SQ6VG	38.7	45.5	55.0	71.5	10
5	500.00	ZS5S0500SQ6VG	60.0	38.5	38.5	55.0	5.8
5	1000.00	ZS5S1000SQ6VG	60.0	61.0	83.0	99.5	12
6	500.00	ZS6S0500SQ6VG	83.1	72.5	75.0	105.5	8.5
6	1000.00	ZS6S1000SQ6VG	83.1	116.0	163.0	192.5	17

13.3 Dimensional drawings

In this chapter, you can find the dimensions of the gear racks.

- Total pitch error
 $\pm 36 \mu\text{m}$ for gear rack length $l_{zs} = 1000 \text{ mm}$
 $\pm 32 \mu\text{m}$ for gear rack length $l_{zs} = 500 \text{ mm}$
- Profile smoothed on all sides

Information on mounting gear racks can be found in the chapter [\[▶ 13.5.2\]](#)

We reserve the right to make dimensional changes due to ongoing technical development.

You can download 3D models of our standard drives at <https://configurator.stoeber.de/en-US/>.

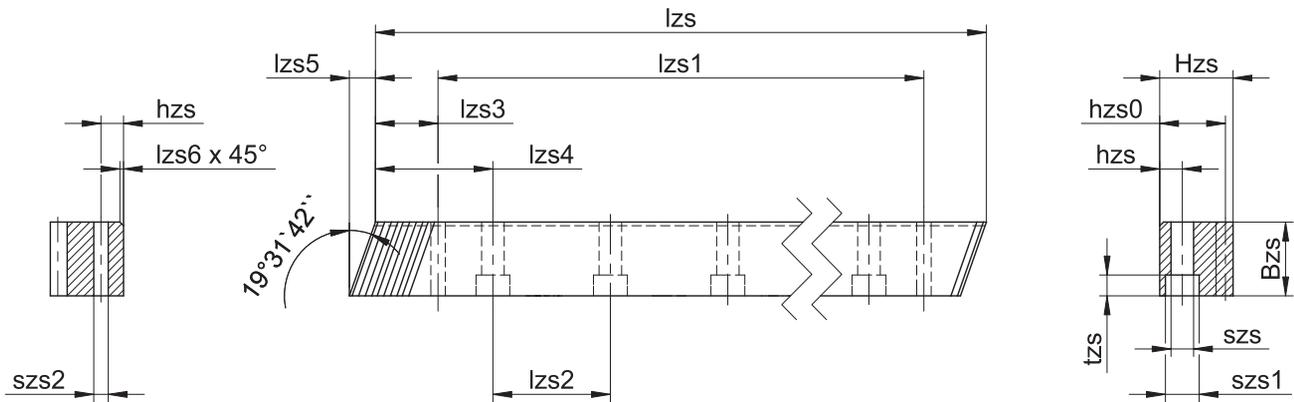

Type	mn	z	lzs	Bzs	Hzs	hzs	hzs0	lzs1	lzs2	lzs3	lzs4	lzs5	lzs6	szs	szs1	szs2	tzs
ZS2S0500SQ6VG	2	75	500.00	24	24	8	22	436.6	62.5	31.7	62.5	8.5	2	7	11	5.7	7
ZS2S1000SQ6VG	2	150	1000.00	24	24	8	22	936.6	62.5	31.7	62.5	8.5	2	7	11	5.7	7
ZS3S0500SQ6VG	3	50	500.00	29	29	9	26	430.0	62.5	35.0	62.5	10.3	2	10	15	7.7	9
ZS3S1000SQ6VG	3	100	1000.00	29	29	9	26	930.0	62.5	35.0	62.5	10.3	2	10	15	7.7	9
ZS4S0500SQ6VG	4	38	506.67	39	39	12	35	433.0	62.5	33.3	62.5	13.8	2	12	18	9.7	11
ZS4S1000SQ6VG	4	75	1000.00	39	39	12	35	933.4	62.5	33.3	62.5	13.8	2	12	18	9.7	11
ZS5S0500SQ6VG	5	30	500.00	49	39	12	34	425.0	62.5	37.5	62.5	17.4	3	14	20	11.7	13
ZS5S1000SQ6VG	5	60	1000.00	49	39	12	34	925.0	62.5	37.5	62.5	17.4	3	14	20	11.7	13
ZS6S0500SQ6VG	6	25	500.00	59	49	16	43	425.0	62.5	37.5	62.5	20.9	3	18	26	15.7	17
ZS6S1000SQ6VG	6	50	1000.00	59	49	16	43	925.0	62.5	37.5	62.5	20.9	3	18	26	15.7	17

13.4 Type designation

In this chapter, you will find an explanation of the type designation of a gear rack with the associated options.

Example code

ZS	4	S	1000	S	Q6	V	G
----	---	---	------	---	----	---	---

Explanation

Code	Designation	Design
ZS	Type	Gear rack
4	Normal module	$m_n = 4$ mm (example)
S	Toothing	Helical (right-hand 19° 31' 42")
0500	Length	1000 mm (example)
1000		
S	Fastening bores	Standard
Q6	Gearing quality	Quality 6 in accordance with DIN 3962-1
V	Material	Heat-treatable steel in accordance with STOBER specification
G	Heat treatment	Hardened

13.4.1 Nameplate

An example gear rack nameplate is explained in the figure below.

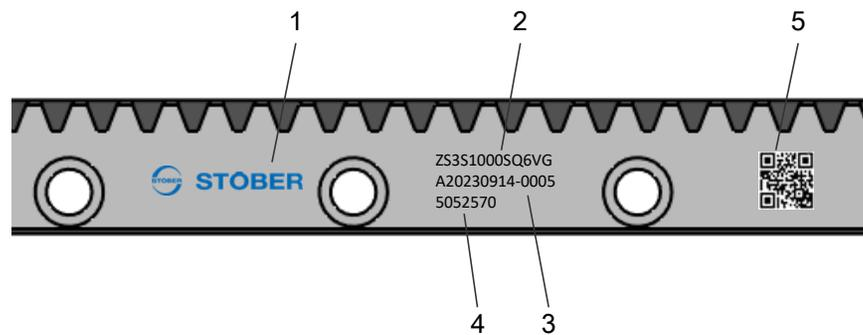

Code	Designation
1	Name of manufacturer
2	Type designation
3	Production number of the gear rack
4	ID No.
5	QR code (link to product information)

13.5 Product description

13.5.1 Lubricants

STOBER recommends the following lubricants for the rack and pinion drive:

- Klüber Microlube GB 0
- Klüber Structovis AHD
- Oest Langzeitfett LT 200
- BP Energrease LS EP 00
- DEA Glissando 6833 EP 00
- Fuchs Lubritech Gearmaster ZSA
- Molykote G-Rapid plus 3694

13.5.2 Accessories

13.5.2.1 Lubricant accessories

Supply sources

You can obtain lubricant accessories from the following companies:

DLS Schmierysteme GmbH https://www.dls-schmierysteme.de/	Gruetzner GmbH https://g-lube.com/de/
STW - Kim Friedrich GmbH https://schmiertechnikwerk.com/	perma-tec GmbH & Co. KG https://www.perma-tec.com/

13.5.2.2 Mounting gear rack

In this chapter, you can find the dimensions of the mounting gear racks.

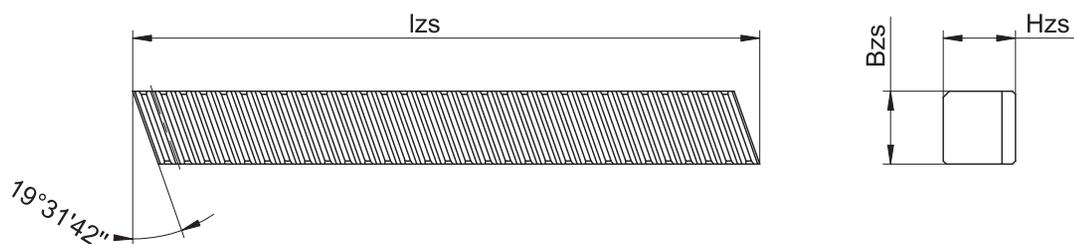

ID No.	mn	lzs	z	Bzs	Hzs	m
5052582	2	200	30	24	24	0.82 kg
5052583	3	200	20	29	29	1.16 kg
5052584	4	200	15	39	39	2.13 kg
5052585	5	200	12	49	39	2.60 kg
5052586	6	200	10	59	49	3.96 kg

13.6 Project configuration

Project your drives using our SERVOfsoft designing software. Download SERVOfsoft free of charge after registration at <https://www.stoeber.de/en/services/info-servofsoft/>.

It is the most convenient and reliable method of drive selection, as the entire torque/speed curve of the application is displayed and evaluated here in the curve of the geared motor.

In this chapter, only limit values for specific operating points can be taken into consideration for manual drive selection.

The formula symbols for values actually present in the application are marked with *.

An explanation of the formula symbols can be found in the chapter [\[14.1 \]](#).

13.6.1 Drive selection

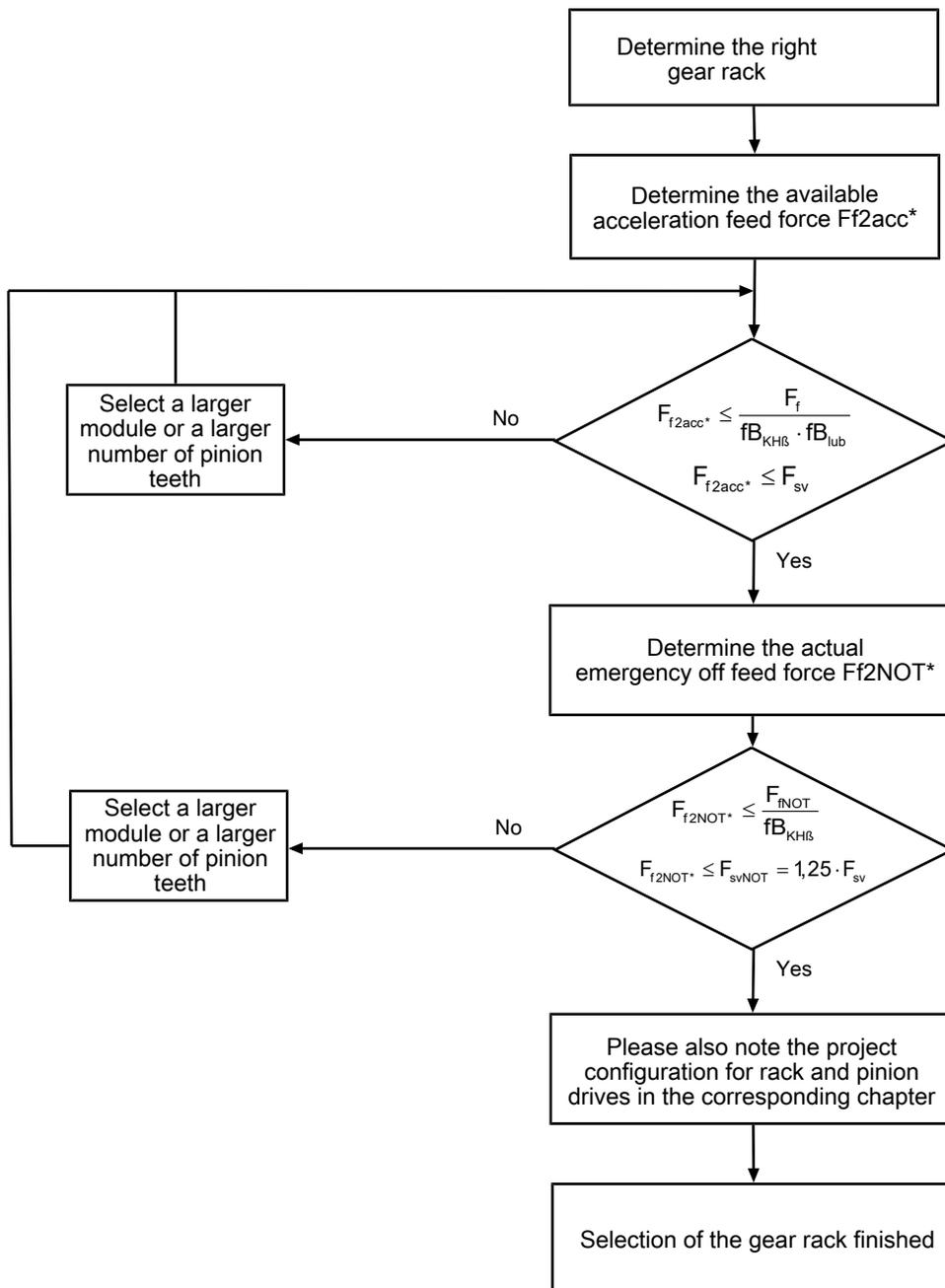

Refer to the selection tables for the values of F_{sv} .

The values for $fb_{KH\beta}$, fb_{lub} , F_f and F_{fNOT} can be found in the corresponding table in this chapter.

Calculation of the actual maximum acceleration feed force

$$F_{f2acc*} = m \cdot a^* + F_L^*$$

Calculation of the actual emergency off feed force

$$F_{f2NOT} = m \cdot a_{NOT} + F_L$$

Operating factors

Load distribution	Bearing design		fB _{KHB}
ZTRSPH	S		1.1
	V		1.1
ZTRSPHQ	S		1.1
ZTRSPHV	S		1.1
ZTRPH	S		1.2
	V		1.2
ZTRPHV	S		1.2
ZRPB	S		1.2
	V		1.2
ZVP	S		1.5
	D		1.3
ZVPE	S		1.8
ZVKS	-		1.2
ZVKL	-		1.5
ZVK	-		1.2

Lubrication	fB _{lub}		
	Permanent	Daily	Monthly
v _{f2maxZB} ≤ 1 m/s	1.0	1.1	5
v _{f2maxZB} ≤ 2 m/s	1.05	1.3	5
v _{f2maxZB} ≤ 3 m/s	1.1	1.5	5
v _{f2maxZB} ≤ 5 m/s	1.25	1.9	5

13.6.2 Permitted feed forces depending on the number of pinion teeth

Permitted feed force F_f in kN:

z_{pin}	$m_n = 2 \text{ mm}$	$m_n = 3 \text{ mm}$	$m_n = 4 \text{ mm}$	$m_n = 5 \text{ mm}$	$m_n = 6 \text{ mm}$
12	5.8	10.4	19.3	30.8	45.3
13	6.4	11.7	21.2	34.0	50.3
14	7.1	12.8	23.7	37.9	55.2
15	8.1	14.4	26.2	42.0	61.4
16	8.6	15.5	28.0	44.2	64.4
17	9.1	16.5	30.0	47.4	69.3
18	9.8	17.4	31.4	50.3	73.6
19	10.4	18.4	33.4	53.5	77.5
20	11.0	19.3	35.2	55.2	79.2
21	11.5	20.6	36.8	57.9	79.8
22	12.2	21.3	37.3	57.9	80.3
23	12.3	21.6	37.3	57.9	80.3
24	12.4	21.9	37.4	58.0	80.5
25	12.4	21.9	37.6	58.3	81.0
26	12.4	21.9	37.7	58.6	81.0
27	12.4	21.9	37.8	58.6	81.1
28	12.5	22.0	38.0	58.6	81.5
29	12.5	22.0	38.1	58.7	81.5
30	12.5	22.1	38.2	58.9	81.6
31	12.5	22.1	38.3	59.1	81.9
32	12.5	22.1	38.3	59.4	81.9
33	12.6	22.3	38.3	59.6	82.6
34	12.6	22.3	38.3	59.6	82.6
35	12.6	22.4	38.3	59.6	82.6
36	12.6	22.4	38.3	59.6	82.8
37	12.6	22.4	38.4	59.7	82.8
38	12.6	22.4	38.5	59.9	82.8
39	12.6	22.4	38.6	60.0	83.1
40	12.6	22.5	38.7	60.0	83.1

Permitted emergency off feed force F_{NOT} in kN:

z_{pin}	$m_n = 2 \text{ mm}$	$m_n = 3 \text{ mm}$	$m_n = 4 \text{ mm}$	$m_n = 5 \text{ mm}$	$m_n = 6 \text{ mm}$
12	11.6	20.8	38.6	61.6	90.6
13	12.8	23.4	42.4	68.0	100.6
14	14.2	25.6	47.4	75.8	110.4
15	16.2	28.8	52.4	84.0	122.8
16	17.2	31.0	56.0	88.4	128.8
17	18.2	33.0	60.0	94.8	138.6
18	19.6	34.8	62.8	100.6	147.2
19	20.8	36.8	66.8	107.0	155.0
20	22.0	38.6	70.4	110.4	158.4
21	23.0	41.2	73.6	115.8	159.6
22	24.4	42.6	74.6	115.8	160.6
23	24.6	43.2	74.6	115.8	160.6
24	24.8	43.8	74.8	116.0	161.0
25	24.8	43.8	75.2	116.6	162.0
26	24.8	43.8	75.4	117.2	162.0
27	24.8	43.8	75.6	117.2	162.2
28	25.0	44.0	76.0	117.2	163.0
29	25.0	44.0	76.2	117.4	163.0
30	25.0	44.2	76.4	117.8	163.2
31	25.0	44.2	76.6	118.2	163.8
32	25.0	44.2	76.6	118.8	163.8
33	25.2	44.6	76.6	119.2	165.2
34	25.2	44.6	76.6	119.2	165.2
35	25.2	44.8	76.6	119.2	165.2
36	25.2	44.8	76.6	119.2	165.6
37	25.2	44.8	76.8	119.4	165.6
38	25.2	44.8	77.0	119.8	165.6
39	25.2	44.8	77.2	120.0	166.2
40	25.2	45.0	77.4	120.0	166.2

13.7 Additional documentation

Additional documentation related to the product can be found at

<http://www.stoeber.de/en/downloads/>

Enter the ID of the documentation in the Search term field.

Documentation	ID
Operating manual gear racks	443392_en

14 Appendix

Table of contents

14.1 Formula symbols	204
14.2 Trademarks	205
14.3 Sales terms and delivery conditions	205
14.4 Publication details	205

14.1 Formula symbols

The formula symbols for values actually present in the application are marked with *.

Symbol	Unit	Explanation
a^*	m/s^2	Acceleration
a_{NOT}^*	m/s^2	Emergency off acceleration
C_{lin}	$N/\mu m$	Total linear spring rigidity
d_o	mm	Pitch circle diameter
d_{MW}	mm	Motor shaft diameter
Δs	mm	Linear backlash resulting from the backlash of the gear unit
Δs_{red}	mm	Reduced linear backlash resulting from the backlash of the gear unit
F_{1k}^*	N	Static and dynamic loads present in the application from the weight of the motor, mass acceleration and vibrations at the gear unit input
$fB_{KH\beta}$	–	Load distribution operating factor (takes into account uneven load distribution across the tooth width)
fB_{lub}	–	Lubrication operating factor
fB_{op}	–	Operating mode operating factor
fB_t	–	Runtime operating factor
fB_T	–	Temperature operating factor
F_f	kN	Permitted feed force
$F_{f,max}$	kN	Maximum permitted feed force
$ F_{f2} $	kN	Absolute value of feed force at output
$F_{f2,1}^* - F_{f2,4}^*$	kN	Existing feed force in the respective time segment (1 to 4)
$F_{f2,n}^*$	kN	Existing feed force in the nth time segment
F_{f2acc}	kN	Permitted acceleration feed force at the gear unit output
F_{f2acc}^*	N	Actual acceleration feed force at the gear unit output
F_{f2accE}	kN	Permitted acceleration feed force at the gear unit output, pinion position E
F_{f2accS}	kN	Permitted acceleration feed force at the gear unit output, pinion position S
F_{f2eq}	kN	Equivalent feed force at the gear unit output
F_{f2eq}^*	kN	Actual equivalent feed force at the gear unit output
F_{f2N}	kN	Nominal feed force at the gear unit output for $n_1 = 500$ rpm
$F_{f2N,E}$	kN	Nominal feed force at the gear unit output for $n_1 = 500$ rpm, pinion position E
$F_{f2N,S}$	kN	Nominal feed force at the gear unit output for $n_1 = 500$ rpm, pinion position S
F_{f2NOT}	kN	Emergency off feed force of the gear unit at the gear unit output for a maximum of 1000 load changes
F_{f2NOT}^*	kN	Actual emergency off feed force at the gear unit output
$F_{f2NOT,E}$	kN	Emergency off feed force of the gear unit at the gear unit output for a maximum of 1000 load changes, pinion position E
$F_{f2NOT,S}$	kN	Emergency off feed force of the gear unit at the gear unit output for a maximum of 1000 load changes, pinion position S
F_{fNOT}	kN	Emergency off feed force for a maximum of 1000 load changes
F_L^*	N	Existing load force
F_{sv}	kN	Transmittable feed force of the screw connection
$F_{svLA125PIN}$	kN	Transmittable feed force of the screw connection with 125 mm hole spacing, pinned
$F_{svLA62.5}$	kN	Transmittable feed force of the screw connection with 62.5 mm hole spacing
$F_{svLA62.5PIN}$	kN	Transmittable feed force of the screw connection with 62.5 mm hole spacing, pinned
F_{svNOT}	kN	Transmittable emergency off feed force of the screw connection for a maximum of 1000 load changes
i	–	Gear ratio
l_{zS}	mm	Gear rack length
m^*	kg	Mass to be accelerated
M_{1k}	Nm	Permitted tilting torque at the gear unit input
M_{1k}^*	Nm	Existing tilting torque on the gear unit input
M_{2acc}	Nm	Maximum permitted acceleration torque on the gear unit output
M_{2accE}	Nm	Maximum permitted acceleration torque at the gear unit output, pinion position E

Symbol	Unit	Explanation
M_{2accS}	Nm	Maximum permitted acceleration torque at the gear unit output, pinion position S
m_n	mm	Normal module
n_{1m^*}	rpm	Actual average input speed
n_{1max^*}	rpm	Actual maximum input speed
n_{1maxDB}	min^{-1}	Maximum permitted input speed of the gear unit in continuous operation
$n_{1maxDBEL1,2}$	rpm	Maximum permitted input speed of the gear unit in continuous operation Mounting positions EL1, EL2
$n_{1maxDBEL3,4,5,6}$	rpm	Maximum permitted input speed of the gear unit in continuous operation Mounting positions EL3, EL4, EL5, EL6
n_{1maxZB}	min^{-1}	Maximum permitted input speed of the gear unit in cyclic operation
t	s	Time
$t_{1^*} - t_{4^*}$	s	Duration of the respective time segment (1 to 4)
t_{n^*}	s	Duration of the n-th time segment
$ v_{f2} $	m/s	Absolute value of feed velocity
v_{f2m^*}	m/s	Actual average feed velocity
$v_{f2m,1^*} - v_{f2m,4^*}$	m/s	Actual average feed velocity in the respective time segment (1 to 4)
v_{f2m,n^*}	m/s	Actual average feed velocity in the nth time segment
$v_{f2maxZB}$	m/s	Maximum feed velocity at the gear unit output at n_{1maxZB}
x	mm	Profile offset factor
z	–	Number of teeth
z_{pin}	–	Number of pinion teeth

14.2 Trademarks

The following names are trademarks or registered trademarks of STOBER:

EasyAdapt®	EasyAdapt® is a registered trademark of STÖBER Antriebstechnik GmbH + Co. KG
FlexiAdapt®	FlexiAdapt® is a registered trademark of STÖBER Antriebstechnik GmbH + Co. KG

14.3 Sales terms and delivery conditions

You can find our current sales terms and delivery conditions at <http://www.stoeber.de/en/gtc>.

14.4 Publication details

Product catalog for rack and pinion drives ID 443137_en.

You can find current versions of PDF files online at <http://www.stoeber.de/en/downloads/>.



STÖBER Antriebstechnik GmbH + Co. KG
Kieselbronner Strasse 12
75177 Pforzheim
Germany
Phone: +49 7231 582-0
mail@stoeber.de
www.stoeber.com

Service hotline:
+49 7231 582-3000

